



Sabarmati Gas Ltd.
(A Joint Venture of GSPC and BPCL)

SABARMATI GAS LIMITED

Laying, Installation, Testing and Commissioning of 8" dia. Steel gas pipeline connectivity in PATAN GA (Navjivan to Happy Service Station, Aashapura CNG connectivity)

RESONANCE ENERGY PVT. LTD.

**Specification for Mainline Construction
Tender No. REPL/SGL/STPL/009/22**

0		Issued for RFP	AS	PG	AN
Rev.	Date	Description	Prepared By	Checked By	Approved By



**Laying, Installation, Testing and
Commissioning of 8” dia. Steel gas
pipeline connectivity in PATAN GA**





**TENDER DOCUMENT NO
REPL/SGL/STPL/009/22**

Date: -06/12/2022

CONTENTS

- 1.0 SCOPE
- 2.0 REFERENCE CODES, STANDARDS AND SPECIFICATIONS
- 3.0 REQUIREMENTS OF R.O.U. AND ACCESS THERETO
- 4.0 RIGHT – OF – WAY
- 5.0 HANDLING, HAULINE, STRINGING AND STORING OF MATERIALS
- 6.0 TRENCHING
- 7.0 BENDING
- 8.0 LINING UP
- 9.0 LAYING OF PIPE
- 10.0 BACK – FILLING
- 11.0 TIEING – IN
- 12.0 SPECIAL INSTALLATIONS ON THE PIPELINE
- 13.0 WORKING SPREAD LIMITATIONS
- 14.0 CLAN – UP AND RESTORATION OF RIGHT – OF – WAY
- 15.0 MAINTENANCE DURING DEFECTS LIABILITY PERIOD

	Laying, Installation, Testing and Commissioning of 8” dia. Steel gas pipeline connectivity in PATAN GA	
TENDER DOCUMENT NO REPL/SGL/STPL/009/22		Date: -06/12/2022

1.0 SCOPE

- 1.1 The work being tendered is covered as indicated below:
The brief scope of work covered in this bidding document broadly consist of Laying, Testing and Commissioning of 8” x 9.3 km (approx.) long pipeline and associated facilities for transportation of Natural Gas in Geographical Areas of Patan GA.

S.No	Size X Length	Location/Area	Total Km
1	8” x 9.2 km	Navjivan to Happy Service Station	9.3

Description of the facilities covered in the above are described in following clauses. Entire buried pipeline network system shall be cathodically protected by providing TCP system.

- 1.2.1 The various activities covered in this specification include the following works of pipeline construction

- Clearing, grubbing and grading of Right – of – way
- Construction of all temporary facilities required in connection with the WORKS
- Staking of the pipeline route.
- Handing, hauling, stringing and storing of all materials.
- Trenching
- Field – bending of line pipe
- Lining – up
- Pipeline laying
- Backfilling
- Tiring-in
- Installation of auxiliary facilities and appurtenances forming a part of pipeline installation.
- Cathodic protection
- Clean-up and restoration of Right-of-way
- Maintenance during defects liability period.

- 1.3 Specification shall be read in conjunction with the conditions of all specifications and documents included in the CONTRACT between COMPANY and CONTRACTOR.
- 1.4 CONTRACTOR shall, with due care and vigilance, execute the work in compliance with all laws, by-laws, ordinances, regulations etc. and provide all services and labor, inclusive of supervision thereof, all materials, excluding the materials indicated as “COMPANY” Supplied materials” in the “CONTRACT”, equipment, appliances or other things of whatsoever nature required in or about the execution of the work, whether of a temporary or permanent nature.
- 1.5 CONTRACTOR shall take full responsibility for the stability and safety of all operations and methods involved in the WORK.



Laying, Installation, Testing and Commissioning of 8” dia. Steel gas pipeline connectivity in PATAN GA



TENDER DOCUMENT NO
REPL/SGL/STPL/009/22

Date: -06/12/2022

- 1.6 CONTRACTOR shall be deemed to have inspected and examined the work area(s) and its surroundings and to have satisfied himself so far as practicable as to the form and nature thereof, including sub – surface conditions, hydrological and climatic conditions, the extent and nature of the WORK and materials necessary for the completion of the WORK, and the means of access to the work area(s).
- 1.7 CONTRACTOR shall be deemed to have obtained all necessary information subject as above mentioned as to risks, contingencies and all other circumstances, which may influence the WORK.
- 1.8 CONTRACTOR shall, in connection with the WORK, provide and maintain at his own costs, all lights, guards, fencing, watching etc., when and where necessary or required by COMPANY or by any duly constituted authority and / or by the authorities having jurisdiction thereof for the protection of the WORK and properties or for the safety and the convenience of public and / or others.
- 1.9 Pipeline laying liasioning (including crossings) and getting permission, NOC and SD Refund form the various statutory authorities. Submitting request for (after obtaining the letter from client) permission follow up, assisting in site inspections/ route survey/ site report making/making site inspection drawings, submitting at designated offices resubmission after correction, modification if required, soft and hard copy in nos. as required / if required in sizes, and collecting final permission from the various statutory authorities including NHAI, PWD Railways, Irrigation, Forest, Municipal Corporation etc. Obtaining work permits form various statutory authorities having jurisdiction before execution of the work and complying with all stipulations/conditions/recommendation of the said authorities. And obtain NOC and SD refund from authorities after completion of work. Only statutory fees shall be paid by the owner.

2.0 REFERENCE CODES, STANDARDS AND SPECIFICATIONS

2.1 Reference has been made in this specification to the latest edition of the following codes, standards and specifications:



- a) ANSI B 31.8 - Gas Transmission and Distribution Piping Systems.
- b) ANSI B 31.4 - Liquid Petroleum Transportation Piping Systems.
- c) API 1104 - Standard for Welding pipelines and Related Facilities.
- d) API 1105 - Bulleting on Construction Practices for Oil and Products Pipelines.
- e) Part 1992 - Transportation of Natural and Other Gas by Pipeline Title 49 (US Department of Transportation – Pipeline SafetyStandards)
- f) Part 195 - Transportation of Liquids by Pipeline (US Department of Transportation – Pipeline Safety Standards.)

In case of difference between the requirements of this specification and that of the above referred codes, standards and specifications, the requirements of this specification shall govern.

2.2 For the purpose of this specification the following definitions shall hold :

- the words “Shall” and “Must” are mandatory.
- the works “ Should, “May” and “Will” are non-mandatory, advisory or recommended.

3.0 REQUIREMENTS OF R.O.U. AND ACCESS THERETO

	Laying, Installation, Testing and Commissioning of 8” dia. Steel gas pipeline connectivity in PATAN GA	
TENDER DOCUMENT NO REPL/SGL/STPL/009/22		Date: -06/12/2022

CONTRACTOR shall, before starting any clearing operations, familiarize himself with all the requirements of the Authorities having jurisdiction over the Right of Way for work along the pipeline route or in connection with the use of other lands or roads for construction purpose.

CONTRACTOR shall notify COMPANY well in advance during work progress, the method of contraction for crossing road pipeline, cable, railway, river and other existing obstacles.

CONTRACTOR shall not commence work on such crossing before having obtained approval from the authorities and land owners concerned to the satisfaction of COMPANY. T crossing shall be installed to meet at all times the requirements and conditions of the permit issued by the authorities concerned. In the absence of any specific requirements by authorities, CONTRACTOR shall comply with COMPANY’S instructions.

The right of ingress and egress to the ROW shall be limited to pints where such ROW intersects public roads, Arrangements for other access required by the CONTRACTOR shall be made by him at his own cost and responsibility. And for such access, the conditions of this specification shall also apply.

Where the ROW comes within 30 meters of an existing line or facility CONTRACTOR shall propose and provide methods to safeguard the existing line or facility (e.g. a demarcation fence) No work is allowed in such area without COMPANY’S prior approval.

3.1 Safety measures during construction of pipelines inside the area influenced by high voltage lines.

3.1.1 General

Pipelines which are constructed inside the area of high voltage lines may be electrically influenced by the high voltage lines. The voltage caused by the influence may at times be high enough to pose danger to personnel working on the pipeline. It is imperative therefore that the instructions given below should be strictly observed.

- 3.1.1.1 It is a necessity that all personnel working on the pipeline which is being laid in the area influenced by the high voltage systems, be given clear instructions on measures to be taken
- 3.1.1.2 Vehicles and equipment must be earth-connected This may be effected by attaching an annulated cable or chain (which touches the ground) of adequate length to the underside of the vehicle.
- 3.1.1.3 It is not impossible for plant and/or materials to come within 50m of the center of the high voltage systems, special measures, must be taken to prevent any approach beyond that distance, unless article 3.1.2 is complied with.
- 3.1.1.4 DURING THUNDERSTORMS OR WHEN DISCHARGES ARE OBSERVED ON INSULTORS ALL PERSONNEL MUST LEAVE THE AREA OF THE HIGH VOLTAGE LINE AND PIPELINE.
- 3.1.1.5 To prevent electrical voltage in a non-buried section of the pipeline from rising to



Laying, Installation, Testing and Commissioning of 8” dia. Steel gas pipeline connectivity in PATAN GA



TENDER DOCUMENT NO
REPL/SGL/STPL/009/22

Date: -06/12/2022

dangerous levels, the length of the pipeline section which has been welded together before burial must not exceed the length at which the max. admissible voltage may be induced. This length may be calculated using an approved calculation method.

3.1.1.6 Before a pipeline section is lower into the trench the structure’s earth electrodes indicated in the drawings or determined with calculation method must have been installed and connected both to the pipeline section already buried and to the section which is about to be buried. The electrical connections which serve the purpose of preventing dangerous voltages must have a min. area of 35mm²

Said connections must not be interrupted until after the permanent safety earth connections have been installed and connected to the entire uninterrupted pipeline.

3.1.1.7 The welded connection between the pipeline section and the section already buried must be installed at a distance of at least 50m from the nearest point of a pylon base.

3.1.1.8 Personnel doing work inside the area of influence of the high voltage system must wear electrically insulating foot-wear. (e.g. rubber knee boots) and wear insulating rubber or. Plastic gloves.

3.1.2 Additional measures for work at less than 50m from the centre of the high voltage system.

If work is done at less than 0m from the centre of the high voltage system, the regulations below must be complied with in addition to the rules specified in clause 3.1.1.

3.1.2.1 The work must not be started until agreement has been reached with the authorities which controls the high voltage system, about the implementation of the safety measures specified in this section.



3.1.2.2 Measures must be taken to prevent excavating and hoisting equipments from approaching high voltage lines to within any of the following distances.

This distance depends on the voltage carried, For individual connections the distance must be :

0	-	50 KV	3m
40	-	200KV	5m
200	-	380KV	8m

The measures taken may be as follows:

1. Special selection of equipment, or limiting or blocking certain directions of movement, or limiting the operational area, thereby making it impossible for any work to be done at a distance from the high voltage line of less than the accepted minimum.
2. In case the measures recommended in 1. above are not feasible, installation of clearly visible markers of sufficient height of laying out a “no passage beyond this point” line

	Laying, Installation, Testing and Commissioning of 8” dia. Steel gas pipeline connectivity in PATAN GA	
TENDER DOCUMENT NO REPL/SGL/STPL/009/22		Date: -06/12/2022

of drums painted bright red and white must prevent any work being done inside the danger area. Further, an inspector must be present all the time.

- 3.1.2.3 In the event that a vehicle, crane etc. should accidentally come into contact with a live cable of a high voltage system or flash – over of electrical charge occurs, the driver must not leave his vehicle because this will pose a serious threat to his life.

The vehicle or crane must break the contact **WITHOUT ANY HELP FROM OUTSIDE.**

The driver must not leave his vehicle until he has managed to leave “the dangerous area, or alternatively, when the Electricity Authorities have given notice that the cable(s) have been put out of circuit. In case a serious fire starts in the vehicle, he is permitted to jump from the vehicle, clearing it as far as possible, while the jump should be to a dry spot.

4.0 RIGHT-OF-WAY



The CONTRACTOR is required to perform his construction activities within the width of Right-of-way set aside for construction of pipeline, unless he has made other arrangements with the land owner and/or tenant for using extra land. Variation in this width caused by local conditions or installation of associated pipeline facilities or existing pipelines will be identified in the field or instructed to the CONTRACTOR by COMPANY.

The ROW boundary lines shall be staked by the CONTRACTOR so as to prepare the strip for laying the pipeline. CONTRACTOR shall also establish all required lines and grades necessary to complete the work and shall be responsible for the accuracy of such lines and grades.

4.1 Staking

Prior to cleaning operations CONTRACTOR shall:

- 1) Install Bench Marks, Intersection Points and other required survey movements.
- 2) Stake markers in the centerline of the pipeline at distance of maximum 100 meters for straight line sections and maximum 10 meters for horizontal bends. Wherever ROW centerline has been staked on ground, CONTRACTOR shall exercise care in accurately staking the pipeline centerline, in consultation with COMPANY.
- 3) Stake two ROW markers at least at every 100 meters.
- 4) Set out a reference line with respect to pipeline centerline at a convenient location. Markers on reference line shall be at a distance maximum 100m for straight line sections and maximum 10m for horizontal bends.

	Laying, Installation, Testing and Commissioning of 8” dia. Steel gas pipeline connectivity in PATAN GA	
TENDER DOCUMENT NO REPL/SGL/STPL/009/22		Date: -06/12/2022

5) Install distance markers location and indicating special points, such as but not limited to :

- Contract limits, obstacle crossings, change of wall thickness, including corresponding chain age, etc.

ROW markers shall be staked out at the boundary limits of Right-of-way wherever possible. Row markers shall be painted red with numbers painted in white. Number shall be identical to centerline marker number with letters A (left side) and B (right side) added, (looking, in flow direction) Reference markers shall also carry the same information as its corresponding centerline markers.

Markers shall be of suitable material so as to serve their purpose and shall be colored distinctly for easy identification. CONTRACTOR shall be responsible for the

maintenance and replacement of the reference line markers until the permanent pipeline markers are placed and the as-built drawings are submitted and approved.

Any deviation from the approved alignment shall be executed by CONTRACTOR after seeking COMPANY approval in writing prior to clearing operations.

4.2 **Monuments**

All shrines, monument, border stones, stone walls and the like shall be protected and shall be subjected to no harm during construction. Any violation of the above by the CONTRACTOR shall be brought to the notice of the COMPANY and other concerned authorities, Restoration of the above shall wholly be the responsibility of the CONTRACTOR.

4.3 **Fencing**

Prior to clearing or grading of the Right-of-way or stringing of pipe, CONTRACTOR shall open fences on or crossing the construction Right-of-way and install temporary gate of sound construction made of similar materials and suitable quality to serve purpose of original fence. Adjacent post shall be adequately braced to prevent slackening of the remainder of the fence. Before such fences are cut and opened, CONTRACTOR shall notify the land owner or tenant, and where practicable, the opening of the fences shall be in accordance with the wishes of said owner and tenant. In all cases where CONTRACTOR removes fences to obtain work route, CONTRACTOR shall provide and install temporary fencing, and on completion of construction shall restore such fencing to its original condition.

CONTRACTOR shall install temporary fencing on either side or ROW where in COMPANY's opinion, It is considered essential to ensure safety and noninterference, especially in areas like grassing lands, villages etc.

Fencing shall be removable type wherever necessary, to permit crossing of traffic. The type of fencing must be suitable for the situation in accordance with user. The pole distance shall not be greater than 6m. The minimum height of the fencing shall be 1.2 m above grade.



Laying, Installation, Testing and Commissioning of 8” dia. Steel gas pipeline connectivity in PATAN GA





TENDER DOCUMENT NO
REPL/SGL/STPL/009/22

Date: -06/12/2022

Fencing can consist of one or more rows of smooth wire and/or of barbed wire.

4.4 Row Clearing and Grading

- 4.4.1 All stumps shall be grubbed for a continuous strip, with a width equal to tragic top width plus two meters on either side centre on the pipeline centerline Further all stumps will be grubbed from areas of the construction Right-of- way, where Right- of- way grading will be required. Outside of these areas to be graded and the mentioned trench strip at the option of CONTRACTOR, the stumps may either be grubbed or cut off to ground level. Any stump out off must be left in a condition suitable for rubber- typed pipeline equipment traffic.
- 4.4.2 All grubbed stumps, timber, bush undergrowth and root cut or removed from the Right-of-way wall be disposed of in a manner and method satisfactory to COMPANY, land owner and/or tenant, and Government Authorities having jurisdiction and as soon as practical after the initial removal in no case, it shall be left to interfere with the grading and laying operations, Whenever stumps are grubbed and a hole is left in the ground, CONTRACTOR shall back- fillthe hole and compact it to prevent water from gathering in it and creating a big hole.
- 4.4.3 CONTRACTOR shall grade the pipeline Right-of-way as required for proper installation of the pipeline, for providing access to the pipeline during construction, and for ensuring that the pipeline is constructed in accordance with the good engineering and construction practices.
- 4.4.4 CONTRACTOR shall grade sharp points or low points, without prejudice to section 6.0 of this specification to allow the pipe to be bent and laid within the limits set forthin these specifications and drawings as regards the minimum elastic curvature permitted and shall drill, blast or excavate and rock or other material which cannot be graded off with ordinary grading equipment in other to make an adequate working space along the pipeline.
- 4.4.5 No temporary or permanent deposit of any kind of material resulting from clearing and grading shall be permitted in the approach to roads, railways, streams, ditches, drainage ditches and any other position which may hinder the passage and/or the natural water drainage.
- 4.4.6 The Right-of-way clearing and grading operations shall in no case involve embankment structures of any type and class without prior approval of the authorities having jurisdiction over the same.
- 4.4.7 In the case of natural or artificial deposits of loose soil, sand, heaps of earth, or other fill materials, these walls be removed till stable natural ground level is reached so as to ensure the construction of the pipeline ditch is in stable ground.
- 4.4.8 In the case of Right-of-way clearing and grading on hillside or in steep slope areas, proper barriers or other structures shall be provided to prevent the removed materials from rolling downhill. The Right-of-way cross fall shall not exceed 10%.
- 4.4.9 Wherever the pipeline Right-of-way runs across plantations, alongside farmyards, built up

	Laying, Installation, Testing and Commissioning of 8” dia. Steel gas pipeline connectivity in PATAN GA	
TENDER DOCUMENT NO REPL/SGL/STPL/009/22		Date: -06/12/2022

areas, groups of trees, horticultural spreads, gradients grass fields, ditches, roads, paths, railways or any other area with restrictions of some kind, CONTRACTOR shall grade only the minimum area required for digging and constructing the pipeline. In the said places, CONTRACTOR shall carry out and constructing the pipeline. In the said places, CONTRACTOR shall carry out the works in such a way that damage done from the pipeline construction is kept to a minimum.

4.5 Provision of Detours.

CONTRACTOR shall do all necessary grading and bridging at road, water and other crossings and at other locations where needed, to permit the passage of its men and equipment it is understood that the CONTRACTOR has recognized such restrictive features of the Right-of-way and shall provide the necessary detours and execute the works without any extra cost to COMPANY Public travel shall not be inconvenienced nor shall be wholly obstructed at any point.

CONTRACTOR at his own cost shall furnish and maintain watchman detours lanterns, traffic lights, barricades, signs, wherever necessary to fully protect the public.

CONTRACTOR shall be responsible for moving its equipment and men across or around watercourses. This may require the construction of temporary, bridges or culverts. Temporary bridging or access to fording required for Right-of-Way crossing water courses shall be constructed. CONTRACTOR shall ensure that such temporary works shall not interfere with normal water flow, avoid overflows, keep the existing morphology, unchanged and shall not unduly damage the banks or water courses. No public ditches or drains shall be filled or bridged for passage or equipment until CONTRACTOR has secured written approval of the Authorities having jurisdiction over the same. CONTRACTOR shall furnish COMPANY a copy of such approval.



4.6 Steep and Rocky Terrain.

Grading operations could normally be carried out along the Right-of-way with mechanical excavators or manually in certain areas, grading may have to be resorted to exclusively by blasting.

In rough or steep terrain, CONTRACTOR may have to grade access roads and temporary bypass roads for its own use. Where such access roads do not fall on from land owners and tenants and be responsible for all damages caused by the construction and use of such roads, and at no extra cost to COMPANY, Wherever rocky terrain is encountered, grading shall be carried out in all types of solid rocks which cannot be removed until loosened by blasting, drilling, wedging or by other recognized means of quarrying solid rocks.

Where use of explosives is required in connection with Right-of-way grading and trenching, CONTRACTOR shall comply fully with requirements of the use of explosives as provided under clause 6.3 of this Specification.

4.7 Off Right – of –Way Damages

	Laying, Installation, Testing and Commissioning of 8” dia. Steel gas pipeline connectivity in PATAN GA	
TENDER DOCUMENT NO REPL/SGL/STPL/009/22		Date: -06/12/2022

CONTRACTOR shall confine all its operations within limits of the Right-of- Way. Any damage to property outside ROW shall be restored or settled to the CONTRACTOR’S account.

CONTRACTOR shall promptly settle all of Right-of-way damage claims. Should

CONTRACTOR fail to do so, COMPANY shall give written notice to CONTRACTOR that if CONTRACTOR does not settle such claims within seven days after such notice, COMPANY shall have authority to settle claims from the account of the CONTRACTOR.

5.0 HANDLING, HAULING, STRINGING AND STORING OF MATERIALS.

5.1 General

The CONTRACTOR shall exercise utmost care in handling in pipe and other materials. CONTRACTOR shall be fully responsible for all materials and their identification until such time that the pipes and other materials are installed in permanent installation. CONTRACTOR shall be fully responsible for materials, however, method of storage shall be approved by COMPANY. CONTRACTOR shall reimburse the COMPANY for the cost of replacement of all COMPANY supplied materials damaged during the period in which such materials are in the custody of the CONTRACTOR. It shall be CONTRACTOR’S responsibility to unpack any packing for the materials supplied by COMPANY.

5.1.2 “Taking Over” of Line Pipe

The following stipulations shall apply in case CONTRACT provides for supply of linepipe, bare and / or corrosion coated, by COMPANY.



CONTRACTOR shall receive and „take over“ against requisition, line pipe from the COMPANY’S designated place(s) of delivery as defined in the CONTRACT.

CONTRACTOR shall perform visual inspection of the bare pipes and coating of the corrosion coated pipes, as the case may be, in the presence of COMPANY and all damages shall be recorded. In the case of corrosion coated pipes CONTRACTOR at his option may carry out holiday detection at a prescribed set voltage and record such holidays, in the presence of COMPANY, at the time of „taking over“. However, if CONTRACTOR proposes to perform only visual inspection of coating, then repair of all holidays found at the time of laying the pipeline shall be carried out by the CONTRACTOR at no extra cost to COMPANY. The CONTRACTOR shall be entitled to extra compensation for repair and rectification of defects recorded at the time of taking over as per the rate set forth in the CONTRACT”. Repair of all damages after taking over the delivery of the materials shall be to the CONTRACTOR’S cost. In case of delay in handing over of COMPANY supplied material, CONTRACTOR shall be fully responsible for stopping and rearranging means of transportation at no extra cost to the COMPANY.

5.2 Handling and Hauling of Line Pipe

5.2.1 Bare Pipe

CONTRACTOR shall unload, load, stockpile and transport the bare pipes using suitable

	<p>Laying, Installation, Testing and Commissioning of 8” dia. Steel gas pipeline connectivity in PATAN GA</p>	
<p>TENDER DOCUMENT NO REPL/SGL/STPL/009/22</p>		<p>Date: -06/12/2022</p>

means and, in a manner, to avoid denting, flattening, or other damage to pipes. Pipe shall not be allowed to drop or strike objects which will damage the pipe but shall be lifted or lowered from one level to another by suitable equipment. Lifting hooks when used, shall be equipped with a plate curved to fit the curvature of the pipe. In loading pipe on trucks each length shall be lowered to position without dropping and each succeeding length shall rest on special supports on the truck and shall be separated from the adjacent pipes. After loading, suitable chains and padding shall be placed on suitable skids to keep them clear of the ground and flood water. The CONTRACTOR shall provide all necessary timber or other materials required for the stock-piling. While stacking, the number of allowable layers of bare pipes shall be calculated as per API RP5L1 and shall be agreed with COMPANY. The stacks must be properly secured against sliding and shall consist of pipes of the same diameter and wall thickness. Adjacent stacks of pipes having different dimensional characteristics shall be clearly separated.

Pipes which are damaged at the time of delivery or “taking-over” (When line pipe is supplied by COMPANY), particularly those which are dented, buckled or otherwise permanently deformed, must be stacked separately and may be transported to the sites only when these defects have been repaired or eliminated.

5.2.2 Corrosion coated Pipes



The CONTRACTOR shall load, unload, transport and stockpile the coated pipes using approved suitable means and, in a manner, to avoid damage to the pipe and coating. CONTRACTOR shall submit to the COMPANY, a complete procedure indicating the manner and arrangement used for handling and stacking of coated pipes for COMPANY approval prior to commencement of handling operations.

Use of vacuum lifting equipment’s is preferred. Hooks may also be used for handling the pipes provided they have sufficient width and depth to fit the inside of the pipe and covered with soft material like rubber, Teflon or equivalent, so as not to cause damages to bevel or pipe ends. During hoisting, cables/wire ropes shall have sufficient inclination compared to pipe axis so that they do not come into contact with external coating.

Coated pipes may be handled by means of slings and belts of proper width (minimum 60mm) made of non-metallic/non-abrasive materials, In this case, pipes to be stacked shall be separated row by row to avoid damage by rubbing the coated surface in the process of taking off the slings. Uses of round sectional slings are prohibited.

During handling, suitable handling equipment with proper length of booms shall be used. Fork lifts may be used provided that the arms of the fork lift are covered by suitable pads preferably rubber. Before lifting operations it is essential to ensure that the pipe surface is free from foreign material with sharp edges. Belts/ slings when used shall be cleaned to remove hard materials such as stone, gravel etc. Coated pipes shall not be burn end against any other pipe or any other objects. Rolling, skidding or dragging shall be strictly forbidden.

Coated pipes at all times shall be stacked completely clear-from the ground so that the bottom row of pipes remain free from any surface water. The pipes shall stacked at a slope so that driving rain does not collect inside the pipe.

	Laying, Installation, Testing and Commissioning of 8” dia. Steel gas pipeline connectivity in PATAN GA	
TENDER DOCUMENT NO REPL/SGL/STPL/009/22		Date: -06/12/2022

The coated pipes at all times shall be stacked by placing them on ridges of sand free

from stones and covered with a plastic film or on wooden supports provided with suitable cover. This cover can, for example, consist of dry, germ free straw with a plastic film, otherwise foam rubber may be used. The supports shall be spaced in such a manner so as to avoid permanent bending of the pipes, particularly in case of small diameter pipes with low wall thickness. The pipes shall be stacked so that the uncoated beveled ends are in line at one end thus making differences in length clearly noticeable.

Stacks shall consist of limited number of layers so that the pressure exercised by the pipe's own weight does not cause damages to the coating. Each pipe section shall be separated by means of spacers suitably spaced for this purpose, Stacks shall be suitably secured against falling down and shall consist of pipe sections having the same diameter and wall thickness. The weld bead of pipes shall be positioned in such a manner so as not to touch the adjacent pipes.

Coated Pipes stacked in open storage yards/dump yards shall be suitably covered on top to decrease direct exposure to sunlight.

The ends of the pipes during handling and stacking shall always be protected with bevel protectors.



The lorries/rail wagons shall be equipped with adequate pipe supports having as many round hollow beds as the number of pipes to be placed on the bottom of the lorry bed. Supports shall be provided for at least 10% of the pipe length. These supports shall be lined with a rubber protection and shall be spaced in a manner as to support equal load from the pipes. The rubber protection shall be free from all nails and staples where pipes are in contact. The second layer and all subsequent layers shall be separated from other layers with adequate number of separating layers of protective material such as straw in plastic covers or otherwise to avoid direct touch between the coated pipes.

All stanchions of lorries/rail wagons for transportation shall be covered by non-abrasive material like rubber belts or equivalent. Care shall be executed to properly cover the top of the stanchions and convex portions such as reinforcement of the truck/rail wagon only rivets etc. to prevent damage to the coated surface.

5.3 Stringing of pipe

Pipes shall be unloaded from the stringing trucks and lowered to the ground by means of boom tractor or swinging crane or other suitable equipment using lifting devices as mentioned earlier. Dragging or sliding of pipe shall not be permitted. Special precaution shall be taken during stringing so as to avoid corrosion of coated pipe as per the special requirements previous para. Stringing of pipe shall only be carried out in daylight and after clearing and grading operations have been completed. Pipes shall not be strung along the ROW in rocky areas where blasting may be required, until all blasting is completed and the area cleared of all debris.

The stringing of the pipe on the ROW shall be done in such a manner so as to cause the least interference with the normal use of the land crossed and to avoid damage to and interference

	Laying, Installation, Testing and Commissioning of 8” dia. Steel gas pipeline connectivity in PATAN GA	
TENDER DOCUMENT NO REPL/SGL/STPL/009/22		Date: -06/12/2022

with the pipes. The sequence of pipes must be interrupted at suitable intervals, spaced to coincide with passages, roads, railways, water crossings as well as at other places if requested by landowner/ tenants to permit use of land.

In case line pipe supply is by different manufacturers CONTRACTOR shall string all line pipes of one manufacturer before commencing the stringing of line pipes of another manufacturer.

When parallel pipelines are being constructed, bumping against and contact with the strung sections of pipe shall be avoided, whether the stringing of the pipes for the individual lines is carried separately or simultaneously.

The pipe lengths shall be properly spaced in order to make easier the handling during the welding phase.

It shall be the responsibility of the CONTRACTORS to see that pipe is strung as per the approved drawings for the proper placement of pipe by size, thickness, grade and other specifications. Any additional handling of pipes due to failure to comply with the requirements shall be at the CONTRACTOR’S expense.

5.4 Repair of Damaged pipes:

After the pipes have been strung along the ROW, they shall be inspected by the CONTRACTOR and by the COMPANY. All defective pipe ends shall have to be repaired as per the directions of the COMPANY or as per the requirements of this specification.

5.5 Materials other than line pipe



CONTRACTOR shall receive and take over against requisition all COMPANY supplied materials from COMPANY’S designated place(s) of delivery as defined in the CONTRACT, CONTRACTOR shall perform visual inspection and defects, if any noted, shall be recorded separately. The CONTRACTOR shall be entitled to extra compensation for repair and rectification of such defects at the rates set forth in the “CONTRACT”

The CONTRACTOR shall perform the necessary loading, unloading, hauling from points designated by the COMPANY and storing, if necessary of all materials. The CONTRACTOR shall exercise care in handling, storing and distribution of materials in order to avoid damage and deterioration of these materials and prevent their theft or loss.

Materials excluding line pipe shall be stored in sheltered storages. Such materials shall not be strung on the Right-of-way but shall be transported in covered conveyances for use only at the time of installation.

CONTRACTOR shall ensure that all valves and whenever applicable, other materials are fitted with suitable end covers of the type approved by COMPANY Materials with worked surfaces such as flanges, pipe fittings, etc. must be stacked and handled so as to avoid contact with the ground or with substances that could damage them.

The manufacturer’S instructions regarding temperature and procedure for storing materials

	Laying, Installation, Testing and Commissioning of 8” dia. Steel gas pipeline connectivity in PATAN GA	
TENDER DOCUMENT NO REPL/SGL/STPL/009/22		Date: -06/12/2022

which are subject to alteration of the original properties and characteristics did to unsuitable storage must be strictly complied with and, if required, an adequate heat conditioning shall be provided for these materials. When supplied in containers and packages they must not be thrown or dropped, not handled using hooks which could damage the container or the materials, either during loading / unloading or during successive handing, until their final use.

Storage of coating materials which are susceptible to deterioration or damages especially due to humidity, exposure to high thermal conditions or other diverse whether conditions, shall be suitably stored and protected. These materials shall be kept permanently in store, supported above the ground in a dry place, protected against the weather and transported for use only at the time and in quantities necessary for immediate application. Deteriorated materials shall not be used and replaced with no extra cost to COMPANY.

5.6 Identification

CONTRACTOR shall provide all pipes, bends, etc. greater than 2” with serial numbers as soon as possible and measure their length and state is on the pipes, etc. Pipes to be bent shall be measured prior to bending. Identification (i.e. letter, number and length) shall be indelible.

All serial numbers shall be recorded in a list, which shall also state appurtenant pipe numbers.

Beside recording the stamped – in pipe numbers, length of pipe and painted-on serial numbers, the stamped-in-numbers of T-pieces, bends, valves, etc. and the batch numbers of bends, T-pieces, valves, etc. and the make of valves, shall also be recorded in said list.

Before a pipe length, pipe end, etc. is cut the painted serial number and stamped-in pipe number shall be transferred by CONTRACTOR in the presence of COMPANY to either side of the joint which is to be made by cutting, and the changes shall be recorded in the above-mentioned list stating the (new) length. The results shall be such that all pipes, pups, etc. of diameter greater than 2” bear clear marks painted on.

CONTRACTOR shall explicitly instruct his staff that parts which cannot be identified must not be removed, except after permission by COMPANY.

As a general rule parts must be marked as described above before being moved. In no conditions may unmarked parts be incorporated into the WORK.

6.0 TRENCHING

6.1 Location

CONTRACTOR shall, excavate and maintain the pipeline trench on the staked center line of the pipeline taking in to account the curves of the pipeline.

6.2 Excavation



Laying, Installation, Testing and Commissioning of 8” dia. Steel gas pipeline connectivity in PATAN GA



TENDER DOCUMENT NO
REPL/SGL/STPL/009/22

Date: -06/12/2022

6.2.1 CONTRACTOR shall, by any method approved by COMPANY, dig the pipeline trench on the cleared and graded Right-of-way. In cultivable land and other areas specifically designated by the COMPANY, top 600mm of the arable soil on the pipeline trench top and 500mm on either side shall be excavated and stored separately to be replaced in original position after backfilling and compacting rest of the trench.

Suitable crossing shall be provided and maintained over the open ROW where necessary, to permit general public, property owners or his tenants to cross or move stock or equipment from one side of the trench to the other.

Care shall be exercised to see that fresh soil recovered from trenching operation, intended to be used for backfilling over the laid pipe in the trench, is not mixed with loose debris or foreign material. The excavated materials shall never be deposited over or against the strung pipe.

6.2.2 In steep slope area or on the hillside, before commencing the works, proper barriers or other protection shall be provided to prevent removed materials from rolling downhill.

6.2.3 On slopes where there is danger of landslide, the pipeline trench shall be maintained open only for the time strictly necessary. Further, the COMPANY may require excavation of trench by hand, local route detours and limiting the period of execution of the works.

6.2.4 In certain slope sections before the trench cuts through the water table, proper drainage shall be ensured both near the ditch and the Right-of-Way in order to guarantee soil stability.

6.2.5 All sewers, drains ditches and other natural waterways involved in the execution of the works shall be maintained open and functional. The same applied to canals, irrigation canals, pipelines and buried facilities crossed by the ditch for which temporary pipeline shall be laid, if required, and proper temporary installations provided.

6.3 Blasting

Blasting for trenching and the related removal of scattered rock and debris caused by the blasting from the Right-of-way and / or adjacent property, shall be performed by CONTRACTOR as part of his work.

Every possible precaution shall be taken to prevent injuries and damages to personal and properties during blasting operations, which shall be performed in accordance with Standard Rules for Blasting.

CONTRACTOR shall obtain necessary permits for storage and use of explosives and comply with the laws, rules and regulations of the respective Governmental agencies having jurisdiction thereof. No blasting will allowed without prior and due notice given by CONTRACTOR to COMPANY Government authorities, land – owners, property occupants, adjacent work crew, and other concerned parties.

CONTRACTOR shall employ only such workmen who are experienced in the type of work to be performed, to supervise, handle and use explosives.

6.3.1 Blasting Effects



Laying, Installation, Testing and Commissioning of 8” dia. Steel gas pipeline connectivity in PATAN GA



TENDER DOCUMENT NO
REPL/SGL/STPL/009/22

Date: -06/12/2022

No blasting should be carried out within city limits and near any third-party structures / facilities. In any case blasting shall only be used after proper authorization from civil authorities even if it is safe to carry out such operations.

- 6.3.2** All necessary precautions shall be taken to prevent stones from falling outside the Right-of-way and in cultivated areas and to avoid any damage to the installation and properties existing nearby.
- 6.3.3** Blasting and removal of debris shall be carried out prior to stringing the pipes.
- 6.3.4** Ground vibration due to blasting – near the existing structures shall be continuously monitored using certified instruments to be provided by CONTRACTOR and approved by COMPANY and the peak particle velocities shall not exceed 50mm/sec.

COMPANY reserves the right to refuse blasting where possible danger exists to property, existing utilities or other structures, In such locations other methods of extracting rock shall be proposed by CONTRACTOR and shall be approved by COMPANY.



6.4 Normal Cover and trench Dimensions:

The trench shall be excavated to a minimum so as to provide, on both sides of the installed pipeline, a clearance as indicated in the job standard / drawings and to a depth sufficient to provide the minimum cover, as indicated below. The dimensions in the table below shall govern except as noted herein or as shown on the job standards or detailed construction drawings or as required by authorities having jurisdiction, whichever is greatest. Minimum depth of cover shall be measured from the top of pipe corrosion / concrete weight coating (as applicable) to the top of undisturbed surface of the soil or top of graded working strip or top of road or top of rail whichever is lower. Fill materials in working strip shall not be considered to add to the depth of cover.

However, surface of fill material placed to fill hollows may be used to determine the depth of cover subject to prior approval by COMPANY.

Minimum Cover Requirements for Steel Pipelines Location
Min. Cover (Mtr.)

Normal / Rocky terrain	1.0
Minor river / unlined canal / nala crossings,	1.5
Tidal areas and other watercourses.	
Major river crossings	2.5
Rivers with rocky bed	1.5
Lined canals / drains / nalas etc..	1.5
Drainages ditches at roadway and railroads	1.0
Rocky areas	1.0
Cased / uncased road crossings	1.2
Cased railroad crossings	1.7

	Laying, Installation, Testing and Commissioning of 8” dia. Steel gas pipeline connectivity in PATAN GA	
TENDER DOCUMENT NO REPL/SGL/STPL/009/22		Date: -06/12/2022

NOTES:

1. Cover shall be measured from the top of coated pipe to the top of the undisturbed surface of soil or the top of graded working strip, whichever is lower. The fill material in the working strip shall not be considered in the depth of cover.
2. For river / watercourses that are prone to scour and / or erosion, the specified cover shall be measured from the expected lowest bed profile after scouring / erosion. Where scour level cannot be established, an additional cover of minimum 1 meter shall be provided from the existing bed of the river/water course.
3. The cover shall be measured from the top of road or top of rail, as the case may be. Whenever the above provisions of cover cannot be provided due to site constraints, additional protection in form of casing/ concreting etc. shall be provided.
4. Buried piping inside the CGS area shall have a minimum depth of cover of 1.2 m. Where buried pipes come out of the ground, the underground coating on the pipe will continue for a length of at least 300 mm above ground.

6.5 Cutting and Removal of Paving

Whenever it is permitted by Authorities and / or COMPANY to open cut a paved road crossing, or where the line is routed within the road pavement. CONTRACTOR shall remove the paving in accordance with the restrictions and requirements of the authorities having jurisdiction thereof or as directed by COMPANY. The open cut for the road crossing shall be carried out only when the section of pipeline to be laid is complete. After laying the pipeline, backfilling shall be immediately performed and all the area connected with the works shall be temporarily restored.

Throughout the period of execution of such works, CONTRACTOR shall provide and use warning signs, traffic lights or lanterns, barricades, fencing, watchman, etc. as required by the local authorities having jurisdiction and / or COMPANY.



For all roads, paths, walkway etc. which are open-cut, CONTRACTOR shall provide temporary diversions properly constructed to allow the passage of normal traffic with the minimum of inconvenience and interruptions.

The paving shall be restored to its original condition after the pipeline is installed.

6.6 Extra Depth and Clearance

At points where the contour of the earth way require extra depth to fit the minimum radius of the bend as specified or to eliminate unnecessary bending of the pipe according to customary good pipeline practice, or where a deep trench is required at the approaches to crossings of roadways, railroads, rivers, streams, drainage ditches, and the like, CONTRACTOR shall excavate such additional depth as may be necessary at no extra cost to the COMPANY.

CONTRACTOR shall excavate to additional depth where the pipeline approaches and crosses other pipelines, sewers, drain pipes, water mains, telephone, conduits, and other underground structures, so that the pipeline may be laid with at least 500 mm free clearance from the obstacle or as specified in the drawings, or such greater minimum distances as may be required by authorities having jurisdiction.

	Laying, Installation, Testing and Commissioning of 8” dia. Steel gas pipeline connectivity in PATAN GA	
TENDER DOCUMENT NO REPL/SGL/STPL/009/22		Date: -06/12/2022

Where the pipeline crosses areas whose easements specifically require greater than normal depths of cover, the trench shall be excavated to extra depth in accordance with the Right-of-way Agreements or as required.

CONTRACTOR shall excavate all such additional depths as may be necessary at no extracost to the COMPANY.

6.7 Grades, Bends and Finish of Trench

The trench is to be cut to a grade that will provide a firm, uniform and continuous support for the pipe. Bends shall be made in the pipe at significant changes in grade of the trench. COMPANY reserves the right to set the grade of the trench and locate the bends if so desired, in which case CONTRACTOR shall excavate, at no extra cost, the trench and bend the pipe to such a grade. COMPANY desires to reduce to a minimum the required number of cold fieldbends to lay the pipe to conform to the general contour of the ground and maintain a normal cover. This can be accomplished by cutting the trench slightly deeper at the crest of ridges and by gradually deepening the trench in approaches to crossings. Such trenching work shall be done by CONTRACTOR at no extra cost to the COMPANY.

COMPANY intends that there will be a minimum of hand grading of the trench bottom. However, to achieve this, CONTRACTOR will have to dig as square a bottom of the trench as possible with his equipment. This in part can be obtained by adjusting and adopting the crumbling shoe and digging teeth of the trenching machines and by use of a drag behind the trenching machines or manually dressing-up the same. CONTRACTOR shall do such hand work in the trench as is necessary to free the bottom of the trench from loose rock and hard clods and to trim protruding roots from the bottom and side walls of the trench.



6.8 Padding

In all cases where rock or gravel or hard soil is encountered in the bottom of the trench, COMPANY will decide the exact extent of trench padding, that will be required. The thickness of the compacted padding shall not be less than 150mm. In those areas that are to be padded, the trench shall be at least 150mm deeper than otherwise required, and evenly and sufficiently padded to keep the pipe, when in place, at least 300 mm above bottom of excavated trench.

Acceptable padding shall be placed under the pipeline before its installation, and around after installation to establish at both sides and on top of the pipe a permanent layer of padding. The thickness of compacted padding on top of pipe shall be at least 300 mm. Padding materials that are approved by COMPANY shall be graded soil/ sand and / or other materials containing no gravel. Rock, or lumps of hard soil. Sand used for padding shall pass through sieve size ASTM-10 or ISO-2.00.

When specified in the CONTRACT, rock shield may be used in place of or in addition to sand padding as indicated above. Such rock shield shall be in accordance with the specification issued for the purpose and shall be subjected to COMPANY approval.

6.9 Protection of Trench

	Laying, Installation, Testing and Commissioning of 8” dia. Steel gas pipeline connectivity in PATAN GA	
TENDER DOCUMENT NO REPL/SGL/STPL/009/22		Date: -06/12/2022

CONTRACTOR shall keep the trench in good condition until the pipe is laid, and no claim is to be made to the COMPANY by reason of its caving either before or after pipe is laid.

All lumber, sheet-piling jacks or other materials, that may be necessary to shore the trench, in order to prevent caving are to be furnished and removed by CONTRACTOR.

CONTRACTOR shall dewater if necessary, using well point system or other suitable system, shore, or do what else might be required to excavate the trench, install the pipe in it and backfill the trench in accordance with these specification at no extra cost to COMPANY.

6.10 Protection of Underground Utilities and Special Methods

Details of some underground utilities, as far as acquired by COMPANY, shall be indicated in the Drawings. However, CONTRACTOR shall obtain plans and full details of all existing and planned underground services from the relevant Local Authorities and shall follow these plans closely at all times during the performance of work. CONTRACTOR shall be responsible for location and protection of all underground lines and structure. In special locations the use of trenching machine, backhoe may result in damage to property and subsurface structures likely to be excavate the trench manually to same specification at no extra cost.

Where the pipeline crossed another underground utilities/ structures, the CONTRACTOR shall first manually excavate to a depth and in such a manner that the utilities/ structures are located.

Temporary under pinning or any other type of supports and other protective devices necessary to keep the interfering structure intact shall be provided by the CONTRACTOR at his own cost and shall be of such design as to ensure against their possible failure.



6.11 Encroachments and Working near other Utilities

In locations, where pipeline has to be laid in the body of a road, canal, dyke or other locations under jurisdiction of Government/ Public Bodies, the CONTRACTOR shall perform such work without extra compensation, according to the requirement of concerned Authorities. When it becomes necessary that CONTRACTOR has to resort to hand digging, well point, erection of sheet piling or any other special construction methods in these areas, no extra compensation shall be paid. CONTRACTOR shall contact the Authorities concerned in order to become familiar with their requirements.

In locations, where the pipeline has to be laid more or less parallel to an existing pipeline, cable and / or other utilities in the Right-of-way, CONTRACTOR shall perform the work to the satisfaction of the Owner / Authority of the existing pipeline / cable/ utility. In such locations CONTRACTOR shall perform work in such a way that even under the worstweather and flooding conditions, the existing pipeline/ utilities remain stable and shall neither become undermined nor have the tendency to slide towards the trench.

CONTRACTOR shall be liable for any damage occurring to, or resulting from damage to other pipelines, underground structure/ utilities, as laid down in clause 6.10 of this specification.

6.12 Provisions for negative buoyancy to the pipe

	<p>Laying, Installation, Testing and Commissioning of 8” dia. Steel gas pipeline connectivity in PATAN GA</p>	
<p>TENDER DOCUMENT NO REPL/SGL/STPL/009/22</p>		<p>Date: -06/12/2022</p>

CONTRACTOR shall check if up-floating danger is present in open trench and then shall take appropriate measures to prevent up-floating such as applying soil dams and dewatering of trench or temporary filling of water into the line (in exceptional cases).

In the case of water on the ditch bottom when the pipeline is being laid, the ditch shall be drained to the extent and for the time required to make a visual inspection of the ditch bottom. After this inspection, the presence of water will be allowed provided its level does not cause siding of the ditch sides and pipe floating before backfilling when no concrete weighting is provided.

The water pumped out of the ditch shall be discharged into a natural water course.

Wherever up-floating of the pipeline after backfilling is to be reckoned with, anti-buoyancy measures shall be provided by CONTRACTOR for areas indicated in the drawings or as may be encountered during construction, using one or a combination of the following methods:

- Weighting by applying a continuous concrete coating around the pipe;
- Weighting by installing saddle weights;
- Installing metal anchors screwed into the subsoil in pairs;
- Deeper burial of pipeline;
- Provision of select backfill material.

The above provisions shall be in accordance with the relevant specifications and/or job standards/drawings. Anti-buoyancy measures adopted shall be such that specific gravity of resulting installation is 1.10 or more.

Pipelines and mains installed in the areas normally under water or subject to flooding (i.e. lakes, bays, or swamps etc.) shall be provided with additional anti-buoyancy measures such as concrete weight coating geo-textile bags filled with graded stones or anchorages etc to prevent floatation. Minimum specific gravity of installation be 1.2 after providing anti-buoyancy measures.

7.0 BENDING

CONTRACTOR shall preferably provide for changes of vertical and horizontal alignment by making elastic bends CONTRACTOR may provide cold field bends, at its option for change of direction and change of stop COMPANY at its option, may authorize fabricated bends for installation at points where in COMPANY's judgment the use of such bends is unavoidable.

Over bends shall be made in such a manner that the center of the bend clears the high points of the trench bottom Sag bends shall fit the bottom of the trench and side bends shall conform and leave specified clearance to the outside wall of the trench.



Laying, Installation, Testing and Commissioning of 8” dia. Steel gas pipeline connectivity in PATAN GA



TENDER DOCUMENT NO
REPL/SGL/STPL/009/22

Date: -06/12/2022

7.1 Elastic Bends

The minimum allowable radius for elastic bends in the buried pipeline including that for continuous concrete weight coated pipe shall be in accordance with relevant job standards. The elastic bend shall be continuously supported over its full length. A radius smaller than permitted in elastic bending shall require a cold bend.

7.2 Cold Field Bends

7.2.1 The radius of cold field bends shall not be less than 40 times the pipe nominal diameter for pipe diameter 18 inch and above and shall not be less than 30 times the pipe nominal diameter for pipe diameter less than 18 inch.

7.2.2 CONTRACTOR shall use a bending machine and mandrel and employ recognized and accepted methods of bending of coated pipe in accordance with good pipeline construction practice. However, bending machines shall be capable of making bends without wrinkles, buckles, stretching and with minimum damage to the coating.

7.2.3 CONTRACTOR shall before the start of the work, submit and demonstrate to COMPANY a bending procedure which shall conform with the recommendations of the manufacturer of the bending machine. The procedure shall include amongst other steps-lengths, maximum degree per pull and method and accuracy of measurement during pulling of the bend. This procedure and the equipment used shall be subject to COMPANY's approval.

7.2.4 Pipes with longitudinal welds shall be bent in such a way that the weld lies in the plane passing through the neutral axis of the bend which shall be installed positioning the longitudinal weld in the upper quadrants. If horizontal deviations are to be achieved by joining more adjacent bends. The bending of the pipe lengths shall be made by positioning the longitudinal welds alternatively 70mm above and below the plane passing through the neutral axis in such a way that the bends are welded with the longitudinal welds displaced by about 150 mm and situated in the upper quadrants, In case of vertical bends formed from a number of pipe lengths, the longitudinal welds shall be positioned on the plane passing through the neutral axis of the bend to the right and left alternatively.

7.2.5 The pads, dies and rolls of the bending equipment shall have relatively soft surfaces to avoid damage to the pipe coating. Where applicable, fully retaining bending shoes shall be used. Roller type bending machines are preferred.

7.2.6 The ends of each bent length shall be straight and not involved anyway in the bending. The length of the straight section shall permit easy joining in no event shall the end of the bend be closer than 1.5 m from the end of a pipe or within one meter of a girth weld.

7.2.7 The ovalisation cause on each pipe by bending shall be less than 2.5% of the nominal diameter at any point. Ovalisation is defined as the reduction or increase in the internal diameter of the pipe compared with the nominal internal diameter. A check shall be performed on all bends in the presence of COMPANY by passing a gauge consisting of two discs with a diameter equal to 95% of the nominal internal diameter of the pipe



Laying, Installation, Testing and Commissioning of 8" dia. Steel gas pipeline connectivity in PATAN GA



TENDER DOCUMENT NO
REPL/SGL/STPL/009/22

Date: -06/12/2022

connected rigidly together at a distance equal to 300mm.

7.2.8 Cold bent pipes on site shall have the corrosion coating carefully checked with the aid of a holiday detector for cracks in the coating down to the pipe wall. It must also be checked whether the coating has disbonded from the pipe wall during bending by beating with a wooden mallet along the outer radius. Any defects or disbonding of the coating caused during bending (also forced ridges in the coating) shall be repaired at the CONTRACTOR's expense in accordance with COMPANY approved procedures.

7.2.9 When pipelines are laid in parallel, the horizontal bends shall be concentric.

7.3 Miter and Unsatisfactory Bends

All bends showing buckling, wrinkles, cracks or other visible defects or which are in any way in disagreement, in whole or in part, with this specification shall be rejected.

No miter bends shall be permitted in the construction of the pipe line. CONTRACTOR shall cut out and remove any bend or bends which do not meet additional cost to the COMPANY. In the event the CONTRACT provides for supply of line pipe by COMPANY. The pipes required for replacement will be furnished by COMPANY, but the cost of replacement of such pipes shall be borne by CONTRACTOR.

Cutting of factory-made bends and cold field bends for any purpose are not permitted.

8.0 LINING UP

Each length of pipe shall be thoroughly examined internally and externally to make sure that it is free from visual defects, damage, severe corrosion (seawater pitting), dirt, animals or any other foreign objects. Each length of the pipe shall be adequately swabbed either by use of canvas belt disc of proper diameter or by other methods approved by the COMPANY. Damaged / corroded pipes shall be kept separate. Each length of pipe shall be pulled through just before being welded.

8.1 Pipe Defects and Repairs



It is CONTRACTOR's responsibility to repair all internal and / or external defects.

8.1.1 Acceptability of defects in the pipe detected during inspection at the work site shall be determined in accordance with latest edition of COMPANY'S own materials specification or CODE ANSI B31.8/B31.4 whichever is more stringent.

8.1.2 The maximum permissible depth of dents in pipes up to and including 12 to 3/4 OD is 5mm and for pipes over 12 OD is 2% of the nominal pipe diameter.

8.1.3 Dents which contain a stress concentrator such as scratch, gouge, arc burn or groove, and dents located at the longitudinal, spiral or circumferential weld shall be with pipe identification number is to be submitted to the COMPANY.

8.1.4 Repair on line pipe shall be executed as specified in COMPANY'S material specification or Code ANSI B 31.8/B 31.4 whichever is more stringent. A record of all repairs is to be

	Laying, Installation, Testing and Commissioning of 8" dia. Steel gas pipeline connectivity in PATAN GA	
TENDER DOCUMENT NO REPL/SGL/STPL/009/22		Date: -06/12/2022

maintained by CONTRACTOR. This record, provided with the pipe identification number is to be submitted to the COMPANY.

8.1.5 If due to cutting or repairs, the pipe identification number is removed, it shall be reprinted immediately by CONTRACTOR in the presence of COMPANY. In the event, the CONTRACT provides for supply of line pipe by COMPANY, CONTRACTOR shall be charged for any pipe length due to loss of identification number. No pipe without identification number shall be transported and / or welded into the pipeline.

8.1.6 Repair of damaged pipe ends by hammering and / or heating is not allowed. If the dented area is minor and at least 200mm away from the pipe end, and the steel is not stretched, severed or split in the COMPANY's opinion, the pipe may be straightened with a proper jack.

8.2 Pipe Handling and Skid Spacing

8.2.1 When lifting pipe, care must be taken not to kink or overstress it. Proper pipe slings approved by COMPANY shall be used. CONTRACTOR shall submit his method of skidding and skid spacing for COMPANY'S approval. A strip of soft material shall be placed in between skid and pipe to protect the external coating of the pipe. The material shall be approved by the COMPANY.

8.2.2 The maximum skid spacing is not allowed before the stringer bead and the top and bottom reinforcements are completed, provided that the distance between the incomplete weld and the skid shall not exceed 9(nine) percent of the skid spacing.

8.2.3 Skids shall be at least 1.20 meter long. For pipe with an O.D. of 12-3/4 inch and larger the skids in contact with the pipe shall have a width of at least 200mm. For pipe with an O.D. of less than 12 inch the skids in contact with the pipe shall have a width of at least 150mm. Pipe supports shall be stable, so that pipe movement will not cause the supports to move. Skids shall not be removed under a string before lowering in. The welded pipe shall be maintained on skids at the minimum distance of 500mm above ground. Crotches shall be installed at frequent intervals (at least every 10th support) with a greater number required at bends and undulation grounds.

8.3 Night Caps

At the end of each day's work or every time when joining and welding operations are interrupted, the open ends on the welded strings of pipes shall be capped with a securely closed metal cap or plug as approved by COMPANY so as to prevent the entry of dirt, water, or any foreign matter into the pipeline. These covers shall not be removed until the work is to be resumed. The caps/plugs used shall be mechanical type and shall not be attached to pipe by welding or by any other means which may dent, scratch or scar the pipe.

8.4 Temporary Caps

Whenever the welded strings of pipes are left open at intervals to be tied in later after an



Laying, Installation, Testing and Commissioning of 8” dia. Steel gas pipeline connectivity in PATAN GA



TENDER DOCUMENT NO
REPL/SGL/STPL/009/22



Date: -06/12/2022

appreciable time lag, under roads, railroads, rivers, marshy crossings, etc. temporary caps approved by COMPANY shall be welded to the ends of the pipe.

9.0 LAYING OF PIPE

9.1 Lowering In Trench

- 9.1.1 Lowering can start after removal from ditch bottom of all off cuts, pipe supports, stones, roots, debris, stakes, rock projections below underside of pipe and any other rigid materials which could lead to perforation or tearing of the coating. Sand padding and / or rock shield shall be provided as required in accordance as per specification.
- 9.1.2 Lowering shall follow as soon as possible, after Certification of the Pipe bookup to joint 100 Coating the completion of the joint coating of the pipeline. In the case of parallel pipelines, laying shall be carried out by means of successive operations, if possible without interruption.
- 9.1.3 Before lowering in, a complete check by a full circle holiday detector for pipe coating and for field joint coating shall be carried out and all damages repaired at CONTRACTOR’S cost. All points on the pipeline where the coating has been in contact with either the skids or with the lifting equipment during laying, shall be carefully repaired. If, after checking, it becomes necessary to place the pipeline again on supports at the bottom of the trench, these must be padded in such a way as to prevent damage to the coating, thus avoiding necessity for further repairs when the pipe is finally raised and laid. Before the last operation, a check must be made of the coating at points of contact with the supports.
- 9.1.4 Before lowering in, short completed sections of the pipeline shall be cleaned with compressed air in order to remove all dirt, etc. from the inside of pipe sections.
- 9.1.5 The pipeline shall be lifted and laid using, for all movements necessary, suitable equipment of non-abrasive material having adequate with for the fragility of the coating. Care shall be exercised while removing the slings form around the coated pipe after it has been lowered into the trench. Any damage caused to the coating shall be promptly repaired. Lowering in utilizing standard pipe cradles shall be permitted if CONTRACTOR demonstrates that pipe coating is not damaged. No sling shall be put around field joint coating.
- 9.1.6 Wherever the pipeline is laid under tension, as a result of an assembly error (for example, incorrect positioning of bends, either horizontal or vertical), the trench shall be rectified or in exceptional cases a new assembly shall be carried out, to be approved by COMPANY, so that it fits the excavation and the laying bed.
- 9.1.7 Laying shall be carried out under safe conditions so as to avoid stresses and temporary deformations of the equipment’s which may cause damage to the pipeline itself and to the coating. In localized points where the right-of-way is restricted to the minimum necessary for the transit of mechanical equipment, the laying, shall be carried out using other suitable means. The pipe shall be placed on the floor or the excavation, without jerking, falling, impact or other similar stresses. In particulars, care must be taken that the deformation caused during the raising of the pipe work from the supports, does not exceed the values for the minimum allowable radius of elastic curvature, so as to keep the stresses on the steel

	Laying, Installation, Testing and Commissioning of 8” dia. Steel gas pipeline connectivity in PATAN GA	
TENDER DOCUMENT NO REPL/SGL/STPL/009/22		Date: -06/12/2022



and on the coating within safe limits. The portion of the pipeline between trench and bank shall be supported by as many crane as required and approved by COMPANY for holding the line in gentle S-curve maintaining minimum elastic bend radius as specified in job standard Lowering in and back-filling shall preferably be carried out at the highest ambient temperature.

9.1.8 The pipeline must be laid without interruption for the whole or the length of section available. Where water is present, no laying shall be permitted until the ditch has been drained to the extent and for the time necessary to make visual inspection possible of the bed on which the pipe is to be laid. Following such inspections, the presence of water will be permitted, provided that it is not so high as to cause cave in of the walls of the trench or floating of the pipeline before backfilling, when weighting is not provided for the pipe.

9.1.9 CONTRACTOR shall take precautions immediately after lowering in to prevent the movement of the pipe in trench.

9.1.10 Clearance between Pipelines or Mains and other underground structures

- (a) When a buried steel pipeline or main has to cross any existing underground pipeline, cable, drain or other services, the pipeline shall be laid at least 500 mm below such services.
- (b) When laid parallel to any existing underground cable, drain or other utilities, the pipeline or main shall be laid with a clear horizontal distance of at least 500 mm from existing utility.
- (c) As far as practical, a minimum separation of three (3) meter should be maintained between the steel pipeline or main and footing of transmission tower.
- (d) A clearance sufficiently large to avoid electrical fault current interference shall be maintained between the pipeline and the grounding facilities of electrical transmission lines.
- (e) Clear distance between new steel pipeline or main running parallel to existing pipeline should be minimum 5.0 meters when heavy conventional construction equipment is expected to be utilized. This distance may be reduced, after careful assessment of construction methodologies, to three (3) meters, provided it does not result in unsafe conditions during construction. Existing pipeline should be clearly marked on the ground during construction. Bi- language (local language and Hindi / English) caution signs should be installed while working in such areas.
- (f) While laying more than one new pipelines or mains in the same trench, clear separation of minimum 500mm shall be maintained between adjacent pipelines.
- (g) No pipeline or main should be located within three (3) meters of any habitable dwelling or any industrial building unless it is provided with at least 300 mm of cover over and above minimum cover specified under Table (Sr. No. 6.4) above or special protective measures such as concrete slab, steel casing are provided.

	Laying, Installation, Testing and Commissioning of 8” dia. Steel gas pipeline connectivity in PATAN GA	
TENDER DOCUMENT NO REPL/SGL/STPL/009/22		Date: -06/12/2022

9.2 Overhead Sections and Sections in Tunnel.

9.2.1 The following works shall be completed before proceeding with the assembly and laying of overhead pipelines:

- Construction of the pipe support structures or of mounts on supports.
- Paints and / or coating of the Pipe Work, as indicated in the engineering specification.

9.2.2 The erection of the supports shall be carried out taking care that the elevation and alignment is in accordance with the drawings.

In the case of metal work supports, prefabrication and / or assembly shall take into account the maximum allowed free span and the supports shall not interfere with the pipeline welds.

9.2.3 In case roller supports are used, the roller shall be lubricated, then checked for smooth rotation and, in case of seizure, the defect shall be repaired or roller shall be replaced. In the case of overhead section where the pipeline is slanting, the alignment of the end supports shall be made after placing the pipeline in position. Before installation of the pipe section, all the rollers shall be perfectly centered acting on the seat of the support plates.

The above alignment operations shall be carried out before connecting the overhead section with the ends of the buried section.

9.2.4 Lifting, moving and laying of the pipeline shall be carried out in accordance with the provisions of clause 9.1.5.

An insulation sheet shall be installed to isolate the pipe from the support or support from the earth.

The sheet shall be hard polyethylene at least 5mm thick.

It shall extend at least to 1cm outside the saddles or clamps.

9.2.5 Moving supports, if any, shall be centered on their support and allow for a movement of at least 300mm in both directions.

9.2.6 A comprehensive report / method statement on the laying operation to be used shall be submitted to the COMPANY well in advance for approval. The report as a minimum shall include, but not limited to the following.

- (a) Method of installation by lifting (as a preferred method)
- (b) Pulling method and related calculations, whenever lifting method cannot be used.
- (c) Pulling device and its characteristics.



Laying, Installation, Testing and Commissioning of 8” dia. Steel gas pipeline connectivity in PATAN GA



TENDER DOCUMENT NO
REPL/SGL/STPL/009/22

Date: -06/12/2022

- (d) Method of anchoring the pulling device.
- (e) Characteristics of the pulling rope.
- (f) Braking device, if any
- (g) Pipeline assembly systems.

10.0 BACK – FILLING

10.1 Backfilling shall not be done until the pipe and appurtenances have the proper fit and the pipe is following the ditch profile at the required depth that will provide the required cover and has a bed which is free of extraneous material and which allows the pipe to rest smoothly and evenly. Before any such work is done, it shall be the CONTRACTOR’s responsibility to first secure the approval of COMPANY. If any backfilling is done without COMPANY’s approval, COMPANY will have the right to require removal of the backfill for examination, and the cost of such uncovering and refilling shall be borne by CONTRACTOR. Backfilling of trench in water courses shall be carried out as per the relevant specification issued for the purpose.

10.2 Backfilling shall be carried out immediately after the pipeline has been laid in the trench, inspected and approved by the COMPANY, so as to provide a natural anchorage for the pipeline, thus avoiding long exposure of coating to high temperature, damaging actions of adverse weather conditions, sliding down of trench sides and pipe movement in the trench. If immediate back filling is not possible, a covering of atleast 200mm of earth, free of rock and hard lumps shall be placed over and around the pipe and coating.

On no account the top soil from the ROW be used for this purpose, In general, the trench shall be dry during backfilling. Deviations thereof must have prior approval of the COMPANY. The backfill material shall contain no extraneous material and / or hard limbs of soil which could damage the pipe / coating or leave voids in the backfilled trench. After the initial backfill has been placed in to the trench to a level slightly above the surrounding ground, CONTRACTOR shall compact the backfill material. The surplus material shall be neatly crowned directly over the trench and the adjacent excavated areas on both sides of the trench as per clause 6.2.1, to such a height which will, in COMPANY’s opinion. Provide specification adequately for future settlement of the trench backfill during the maintenance period and thereafter. The crown shall be high enough to prevent the formation of a depression in the soil when backfill has settled in to its permanent position. Should depression occur after backfill, CONTRACTOR shall be responsible for remedial work at no extra cost to COMPANY. Surplus material, including rock, left from this operation shall be disposed of the satisfaction of land owner or authority having jurisdiction at no extra cost to the COMPANY.

For further requirements reference is made to Section of 14.0 “Clean-up and Restoration of Right-of-way of this specification.

10.3 Rock, gravel, lumps of hard soil or like materials shall not be backfilled directly onto the



Laying, Installation, Testing and Commissioning of 8” dia. Steel gas pipeline connectivity in PATAN GA





TENDER DOCUMENT NO
REPL/SGL/STPL/009/22

Date: -06/12/2022

pipe unless, padding” and/or rock shell has been provided as per Section 6.0 of this specification. When “Padding” as described in Section 6.0 of this specification is to be used the following shall be applicable.

Where rock, gravel, lumps of hard soil or like materials are encountered at the time of trench excavation, sufficient earth, sand or select backfill materials shall be placed around and over the pipe to form a protective cushion extending at least to a height of 150mm above the top of the pipe. Select backfill materials for padding that are acceptable to COMPANY shall be soil, sand, clay or other material containing no gravel, rock or lumps or hard soil. Whether such padding material would be taken from the adjacent spoil bank or imported from elsewhere shall be directed by COMPANY. All these works shall be carried out by CONTRACTOR at no extra cost to COMPANY. Loose rock may be returned to the trench after the required selected backfill material has been placed, provided the rock placed in the ditch will not interfere with the use of the land by landowner or tenant.

- 10.4** When the trench has been dug through drive ways or roads, all backfills shall be executed with sand or a suitable material as approved by COMPANY and shall be thoroughly compacted. In certain cases, special compaction methods, such as moistening or ramming of the backfill in layers may be required by COMPANY. COMPANY and any public or private authority having jurisdiction over a road, street or drive way may require that the surface of the backfill be graveled with crushed rock or some other purchased material and the road shall be repaved. In such instances, CONTRACTOR shall comply with said requirements at no extra cost to COMPANY.
- 10.5** Trenches excavated in dykes which are the property of railways or which are part of main roads shall be graded and backfilled in their original profile and condition. If necessary, new and/or special backfill materials shall be supplied and worked-up. The materials required may include gravel, special stabilization materials or stabilized mixtures. However, special processing and / or compacting methods shall require the approval of COMPANY and / or competent authorities.
- 10.6** The trench in irrigated and paddy fields shall be backfilled to within 300mm of the top then rammed and further backfilled until the trench is completely backfilled. Surplus material remaining after the operation shall be spread over the ROW as specified in Section 14.0 “Clean-up and Restoration of Right-of- Way” of this specification.
- 10.7** At the end of each day’s work, back fitting shall not be more than 500 meters behind the head end of lowered-in pipe, which has been padded and approved for backfill. The backfill shall be maintained by CONTRACTOR against washouts etc., until the completion and final acceptance of the work by COMPANY.
- 10.8** CONTRACTOR shall furnish materials and install breakers in the trench in steep areas (stopped generally 10% and more) for the purpose of preventing erosion of the backfill. The type of breakers installed shall be as per the approved drawings, Breakers shall be constructed of grout bags filled with a mixture of 4:1 sand-Portland cement at COMPANY’s direction. CONTRACTOR may propose other methods such as foam dams etc. which shall be subject to approval by COMPANY, such works shall be at no extra cost to COMPANY.

	Laying, Installation, Testing and Commissioning of 8” dia. Steel gas pipeline connectivity in PATAN GA	
TENDER DOCUMENT NO REPL/SGL/STPL/009/22		Date: -06/12/2022

CONTRACTOR shall pay attention to the direction of backfilling in such steep areas.

10.9 When backfilling the trenches in sloping terrains or steep areas, where in the opinion of the COMPANY, the backfill may be washed out of the trench, sheet piling or other effective water breakers across the trench shall be provided by CONTRACTOR. This is to divert the flow of water away from the trench into normal drainage followed before laying the line. In no case, the water is to be drained via the trench or via channels other than those followed before the line was laid.

10.10 CONTRACTOR shall leave the pipe uncovered at certain location to allow COMPANY to survey the center line of the pipe and the level of the pipeline in the backfilled trench. Within 48 hours after backfilling, COMPANY shall have carried out such survey and informed CONTRACTOR of any realigning if required. Thereafter CONTRACTOR shall compact the backfill.

The maximum allowable deviation from the centerline for land sections as staked out by COMPANY and as referenced by CONTRACTOR after backfilling is limited to:

Pipeline dia up to and including 24” = 200mm Pipeline
greater than 24” = 300mm

10.11 Before backfilling of the trench, CONTRACTOR shall comply with the requirement of Clause 6.12 of this specification. (as per specification).

10.12 Stabilization of backfill shall be carried out by the CONTRACTOR in sandy areas and other such places to obtain consolidated cover as directed by the COMPANY. CONTRACTOR shall carry out the stabilization over the pipeline at no extra cost to COMPANY.

The backfill shall be stabilized preferably with 150mm layer of marl, mattresses of batch other than straw or other stable materials. The width of stabilizations shall be at least 5.0 meters on either side of the pipeline, plus one meter for every 10 meters of dune (where the line passes through the dune areas).



10.13 Temporary workers shall be installed during backfilling and the survey as per clauses 10.10 to locate the pipeline axis. These markers shall then be replaced with permanent pipeline markers.

10.14 Backfilling shall be preferably carried out at the highest ambient temperature.

11.0 TIEING – IN

11.1 The unconnected sections of the pipe line at various locations have to be tied in after the sections are coated, lowered and backfilled. The sections to be connected shall have at the ends, sections of over lapping, uncovered pipe of sufficient length to absorb, without inducing excessive stresses in the steel, small displacements necessary for perfect alignment and connection of the ends.

11.2 Tie-in shall preferably be carried out at ambient temperatures corresponding to the average operating temperature in the case of a pipeline conveying fluids at normal temperatures and

	Laying, Installation, Testing and Commissioning of 8” dia. Steel gas pipeline connectivity in PATAN GA	
TENDER DOCUMENT NO REPL/SGL/STPL/009/22		Date: -06/12/2022

at the maximum ambient temperature in the case where the pipeline is carrying fluids at high temperature.

- 11.3** CONTRACTOR shall carry out tie-in-welding (including necessary cutting, beveling, grinding of pipe weld seams and line-up etc.) cleaning, priming, coating and backfilling for the tie-in portion as per relevant specifications. CONTRACTOR shall also excavate the required bell-holes for the connection. Bell-holes made to facilitate welding shall provide adequate clearance to enable the welders to exercise normal welding ability and skill. All tie-in welds shall be radio graphically examined.
- 11.4** The tie-in should be done in such a way as to leave a minimum of strain in the pipe. If necessary, with respect to the trench, realigning of the pipe shall be done to eliminate force or strain in the pipe by the CONTRACTOR at no extra cost to COMPANY.
- 11.5** If a pup end cannot be avoided for tie-in, the minimum length that shall be added is 1.0 meters and two or more such pups shall not be welded together. All cut-off lengths greater than 1.0 meters shall be moved ahead in order to be welded into the pipeline at a suitable location. Tie-in with two or more pups may be used provided that they each have minimum length of 1.0 meter and are separated by an entire length of pipe. In no case more than three (3) welds shall be permitted on a 10 meter length of pipeline.
- 11.6** In connecting pipes, special items, fittings and equipment where different wall thicknesses are to be welded, CONTRACTOR shall follow the procedures indicated in ANSI B31.8/ANSI B31.4, as applicable. The required tapering shall be done by CONTRACTOR at no extra cost to COMPANY.
- 11.7** For tie-in of adjacent sections of pipeline already pressure tested, the pup used for tie-in shall be of single length or off-cuts of pipe which have already been hydrostatically tested. CONTRACTOR shall take care that sufficient number of protested pipes with different wall thicknesses are readily available.



12.0 SPECIAL INSTALLATIONS ON THE PIPELINE

12.1 General

- 12.1.1** In addition to constructing the pipeline, CONTRACTOR shall also install certain other auxiliary facilities and appurtenances.

CONTRACTOR shall do all work necessary at each of the installations to provide facilities which are complete in all respects and ready for operation.

Without limiting the generality thereof, the work required to complete the installations shall, where applicable, include all site surveys, site preparation, filling, grading, fencing, foundations, installation of block valves, side valves, pipe work, pipe supports, pressure gauges, mechanical facilities, civil work painting, installation of all electrical equipment, motors, cables, conduit, wiring and fixtures and hooking up of same; installation of all instruments, piping, valves and fittings; mount all instruments and make all piping and electronic connections, etc.

	Laying, Installation, Testing and Commissioning of 8” dia. Steel gas pipeline connectivity in PATAN GA	
TENDER DOCUMENT NO REPL/SGL/STPL/009/22		Date: -06/12/2022

On completion, all elements of each installation shall be checked out and tested for full and correct operation in the presence of and to the satisfaction of COMPANY. All work shall be carried out strictly in accordance with the appropriate codes, the approved drawings, and this and other related specifications.

CONTRACTOR shall fabricate all piping and install valves and fittings as required by the detailed engineering drawings prepared by him and approved by COMPANY.

Stainless steel lines will be “swaged” using permanent fittings installed with a hydraulic device.

Cold bending for the fitting of ½” and ¼” pipes is allowed when special bending tools are used with guides to prevent flattening. The minimum radius allowed shall not be less than R=10 D where D is the outside diameter of pipe.

The bending tool shall be subject to COMPANY’s approval.

CONTRACTOR shall ensure that the piping assemblies are not in a strain prior to the final bolting or welding. CONTRACTOR shall also ensure that all equipment and piping are thoroughly swabbed clean of all dust, refuse, welding spatter, scale, or any potentially detachable matter prior to the tie-in or final bolting.

12.1.2 Dimensional tolerances



These tolerances apply to in line items and corrections for other lines. These tolerances can be executed on items such as vents, drains, dummy supports, field supports, temperature and pressure connections, where the deviation will not affect another’s pool.

- a) General dimension such as face to face, face or end to end, face or end to center, and center to center: ± 3 mm.
- b) Inclination of flange face from true in any direction: 4 mm per meter.
- c) Displacement of branch connection from indicated location: ± 1.6 mm. When multiple branches are involved, the displacement of the branches shall not exceed 3mm from a common point.
- d) Rotation of flange bolt holes shall not exceed 1.6mm.

12.1.3 Flanged connections

CONTRACTOR shall ensure that all flange faces are parallel and centered, according to standard practice, prior to final bolting. CONTRACTOR shall not use bolting forces as means for attaining alignment. A gasket of proper size and quality shall be installed between the flanges at each joint.

Bolts shall be tightened in diagonal sequence and shall be centered with equal amounts of thread visible on both sides. Bolts shall be uniformly tightened to produce a leak – proof joint. Bolts that yield during tightening shall be removed and discarded. It is mandatory that a torque wrench is used for bolt tightening.

	Laying, Installation, Testing and Commissioning of 8” dia. Steel gas pipeline connectivity in PATAN GA	
TENDER DOCUMENT NO REPL/SGL/STPL/009/22		Date: -06/12/2022

12.1.4 Threaded Connections

Damaged threads shall be cut from the end of a run and the pipe shall be rethreaded.

CONTRACTOR shall properly align all threaded joints. Pipe entering unions shall be true to centerline so the union will not be forced during tightening. The threaded pipe shall not project through fittings to cause interference with valves or other operating mechanisms.

Except for the threaded connections of instruments, which will require periodic testing and maintenance, all threaded connections shall be seal welded. The letter joints shall be made up without pipe joint compound and with a minimum of oil from the threaded cutter. Seal welds should taper into the pipe with as little discontinuity as possible and should cover all threads.

12.1.5 Welded connections

Where the Ends of the piping components being welded have an internal surface misalignment exceeding 1.6mm, the wall of the component extending internally shall be trimmed by machining so that the adjoining internal surfaces will be approximately flush. All welding shall be performed in accordance with the specification “Specification for welding of pipelines and related facilities”.

Tie-ins between fixed points shall be made at maximum ambient temperature.

12.1.6 Civil Work

Civil work shall be provided in accordance with Specifications issued for the purpose.

12.1.7 Painting



All exposed surfaces like piping, valves, structures, and miscellaneous appurtenances shall be painted in accordance with the specifications issued for this purpose. The corrosion coating on pipe surface will end approximately 0.3 meter above the finish grade and it will be necessary for CONTRACTOR to provide a clean interface at the junction of the protective coating and the paint.

12.1.8 Coating of buried – Installations, etc.

All buried valves, insulating joints, flow tees, bends, other in-line fittings and appurtenances shall be coated with minimum three coats of approved quality of coat- tar epoxy or any other equivalent suitable COMPANY approved coating at no extra cost to the COMPANY. For buried pipes either heat shrink tapes conforming to COMPANY a report used along with all the test certificates. Only after obtaining written approval from the COMPANY CONTRACTOR shall commence the work of coating.

12.1.9 Clean-up

After all required tests have been concluded satisfactorily CONTRACTOR shall clean up

	Laying, Installation, Testing and Commissioning of 8” dia. Steel gas pipeline connectivity in PATAN GA	
TENDER DOCUMENT NO REPL/SGL/STPL/009/22		Date: -06/12/2022

the site as laid down in the specifications issued for the purpose. The Site finish shall be graded in accordance with the approved drawings.

12.2 Installation of Valves and Valve Stations

12.2.1 Block and sectionalizing valve stations shall be installed as shown on the approved drawings. It is CONTRACTOR’s responsibility to have the units completely assembled tested and made fully functional including all related instruments etc.

12.2.2 In steel distribution mains valve spacing should normally not be more than 3 km.

12.2.3 The civil and structural work shall be carried out in accordance with the relevant specifications issued for the purpose and in accordance with the approved drawings as directed by COMPANY. This work as a minimum shall include clearing, grading, fencing, foundations, etc, as required. All above ground structures shall be painted as per the specification and color code given by the COMPANY.

12.2.4 A suitable concrete foundation as directed by COMPANY shall be constructed on which the valve shall be firmly installed, after embedding an insulating sheet of hard polyethylene with a thickness of at least 5mm or equivalent. Such insulating sheet is also to be installed under pipe clamps, etc..

12.2.5 Valves with flow arrows shall be installed according to the normal flow in the pipeline, during welding, the valves shall be in fully open position. In addition all manufacturers’ instructions shall be followed.



Care shall be taken to avoid entry of sand particles etc. to valve body, sealsetc during transportation, storage, assembly and installation.

12.2.6 For valves and piping installed below ground and / or above ground, the anticorrosion coating / painting shall be as per the requirements of the relevant specifications issued for the purpose. The anti-corrosion coating below ground shall extend up to 300mm above grade at the lowest point.

12.2.7 Sectionalizing valves shall be installed on sections of the pipeline in the horizontal position only or with an inclination not greater than that allowed by the valve manufacturer. Installation shall be done in such a way that there is no strain in the welded joint while the pipeline at upstream and downstream sides are straight.

12.2.8 All valves shall always be handled using equipment and methods to avoid impact, shaking and other stresses. In particular, the equipment and tools for lifting and handing shall never be done through hand wheel, valve stem, joints and other parts which may suffer damage.

12.2.9 All sectionalizing valve and any other inline assemblies, shall be prefabricated and tested hydrostatically as per applicable specification. All such assemblies shall be installed at the locations shown in the drawings only after successful completion of the hydrostatic test and dewatering. Thereafter the ends of the assembly shall be closed off. CONTRACTOR shall

	Laying, Installation, Testing and Commissioning of 8” dia. Steel gas pipeline connectivity in PATAN GA	
TENDER DOCUMENT NO REPL/SGL/STPL/009/22		Date: -06/12/2022

carry out necessary excavation, cutting, beveling and welding of the tie-ins required for the installation of such assembly. The tie-in joints shall be epigraphically examined over 100% length and also 100% ultrasonically examined prior to backfilling. All works shall be executed in accordance with the relevant specifications issued for the purpose.

12.3 Installation of Scraper Launchers and Receivers.

12.3.1 Scraper stations shall be fabricated and installed as per the approved drawings and whenever applicable as per the requirements of clause 12.2 of this specification. It is CONTRACTOR’s responsibility to have the units completely assembled, tested and made fully functional including all instruments & related piping.

12.3.2 The civil and structural works for the scraper stations shall be carried out as per the relevant specifications, in accordance with the drawings and as directed by the COMPANY. The work as a minimum shall include site survey, site preparation, clearing, grading, fencing, foundations, etc. as required.

12.3.3 It shall be CONTRACTOR’s responsibility to maintain elevations shown on the approved drawings and to carry out any pipe work adjustments, necessary for this purpose. Field cuts shall be square and accurate and field welds shall not be performed under stress of pipe ends.

12.3.4 The painting for the scraper stations shall be carried out as per “Specifications for Painting” the underground sections shall be coated as specified for the pipeline up to at least 300mm above grade.

12.3.5 The hydrostatic testing of the scraper station shall be executed after installation in accordance with the relevant specification issued for the purpose.

12.4 Installation of Insulation Joints.

12.4.1 Insulation joints shall be installed at the locations shown in the drawings. CONTRACTOR shall obtain approval from the COMPANY before installation of the insulation joints.



12.4.2 Handling and installation of the insulating joints shall be carried out with all precautions required to avoid damage and excessive stresses and that the original pup length is not reduced.

12.4.3 The insulation joints and the welded joints shall be protected by external coating as per relevant specifications issued for the purpose.

12.4.4 The in-line inserting shall be made on the buried pipeline; care shall be taken to operate at an external temperature as close as possible to the pipeline operating temperature.

The joints shall be inserted on straight sections and laid on a fine sand bed.

12.4.5 During the execution of the in-line connection welding, the propagation of heat shall be avoided. To achieve this, the joint shall be kept cold by means of nags continuously

	Laying, Installation, Testing and Commissioning of 8” dia. Steel gas pipeline connectivity in PATAN GA	
TENDER DOCUMENT NO REPL/SGL/STPL/009/22		Date: -06/12/2022

wetted.

- 12.4.6 Insulating joints shall be electrically tested before welding into the pipeline. The electrical conductance test shall be carried out using Meggers. Measurement of the insulation resistance across the joints shall be approx. One (1) Megs. Ohm. The tests shall be repeated after installation and welding of the joint into the pipeline to verify that the assembly is undamaged.

13.0 WORKING SPREAD LIMITATIONS

CONTRACTOR shall, in general, observe the following maximum distances between the working mainline spread :

- Between ROW grading, clearing and backfilling : 40 Kms
Between backfilling and final clean – up : 15 Kms

The above limitations do not apply to point spreads such as continuous rock blasting, river crossing, etc.

Any deviations from the above shall require prior approval of COMPANY. COMPANY reserves the right to stop the work, in case the approved spread limitations are exceeded and CONTRACTOR shall not be paid any compensation for stoppage of work.

14.0 CLEAN – UP AND RESTORATION OF RIGHT OF WAY

- 14.1 CONTRACTOR shall restore the ROW and all sites used for the construction of pipelines, water crossing and other structures in accordance with COMPANY’s instructions, and deliver them to the satisfaction of COMPANY.

14.2 Surplus Materials



The following stipulations shall apply in case CONTRACT provides for supply of line pipe, bare and / or corrosion coated, by COMPANY.

All surplus and defective materials supplied by COMPANY shall be collected by CONTRACTOR and delivered to designated stockpile areas.

All Pipe-ends shorter than 1.0m shall be returned to COMPANY being scrap, all pipes longer than 8.0m shall be reconditioned (bevels, coating, provided with pipe letter, number and length) and be returned to COMPANY’S designated stockpile areas together with all undamaged, unused COMPANY supplied materials. All pieces between 1.0 and 8.0 m shall be charged to the CONTRACTOR by COMPANY, contractor shall record these returned materials in the Material account, to be prepared by him.

14.3 Disposal

- 14.3.1 All surplus and defective materials supplied by CONTRACTOR and all trash, refuse and

	<p>Laying, Installation, Testing and Commissioning of 8” dia. Steel gas pipeline connectivity in PATAN GA</p>	
<p>TENDER DOCUMENT NO REPL/SGL/STPL/009/22</p>		<p>Date: -06/12/2022</p>

spoiled materials shall be collected and disposed of by CONTRACTOR.

14.3.2 The Row shall be cleared of all rubbish, broken skids, empty cans, card board, sacks, stamps, trash, and leftover construction material. All burnable matter shall be burned, but only after obtaining appropriate permits for such burning. If burning is not allowed, CONTRACTOR shall haul the clean-up material to approved dumping area. All scrap metal and unburnable material shall be disposed of, in an appropriate manner, but never be buried in the ROW.

14.3.3 Surplus soil can only be removed from the Owner’s plot after authorization by COMPANY.

14.3.4 All dumping fees connected with the disposal of materials shall be to the account of CONTRACTOR.

14.3.5 All loose stones and rock exposed by the construction operations and scattered over the ROW or adjacent grounds shall be removed by CONTRACTOR and be transported to a location considered suitable by the authorities having jurisdiction, for satisfactory disposal. For stones, gravel or other hard material which may be buried in the trench the provisions of the specifications shall apply with the understanding that the use of the land by the land-owner and / or tenant will not be interfered with.

14.4 Temporary Structures.

All auxiliary structures such as bridges, culverts, sheet piling, posts, signs, etc., which were erected or installed by CONTRACTOR as temporary measure, shall be removed. However, it may be necessary to remove the fence of ROW during the maintenance period.

14.5 Repair of Damage



Damages to roads, bridges, private property shall be repaired by CONTRACTOR. All fences and other structures which are damaged during construction shall be restored to original condition.

Slopes, water course sides or banks which have been partially or totally demolished during the execution of the works shall be properly consolidated and restored without waiting for their natural consolidation and setting.

All boundary stones which have been moved or removed during the work must be reset in their original location to the satisfaction of the landowner concerned.



14.6 On completion of clean-up, the ROW shall be restored to such stable and usable condition as may be reasonably consistent with the condition of the ROW prior to laying the pipeline. The COMPANY shall be completely indemnified and held harmless by CONTRACTOR from any and against all claims, demands, losses; expenses etc. that may arise in this behalf or the COMPANY may require from the CONTRACTOR signed Releases from land owners regarding satisfactory indemnification and restoration of their lands.

14.7 Special precautions shall be taken near slopes prone to erosions and landslides. All

	Laying, Installation, Testing and Commissioning of 8” dia. Steel gas pipeline connectivity in PATAN GA	
TENDER DOCUMENT NO REPL/SGL/STPL/009/22		Date: -06/12/2022

necessary steps shall be taken to ensure the rapid growth of grass by providing wicker barriers and by regulating the drainage of surface waters.

- 14.8** All cadastral or geodetic markers which may have been removed during the execution of the works shall be restored in their exact position.
- 14.9** Ditches for which no instructions for restoration have been issued, or restoration cannot be done according to existing banks because of the absence of it, shall be restored as instructed by COMPANY. The bed of ditches crossed by the pipeline shall be cleaned over the full width or the ROW, also outside the ROW if necessary. This restoration might involve the supply and installation proper materials for backfill and protection, sodding or other precautions to prevent erosion or guarantee the stability. Work has to be done after deliberation and acceptance of the authorities and COMPANY. Other field drains have to be restored by hand and/or special equipment to be used for that purpose as soon as possible and if necessary, also outside the ROW.
- 14.10** Any subsidence, cave-ins, wash-outs, which have been caused during the pipeline construction and maintenance, caused by whatever reason within the edge of ditches and open drains, shall be repaired by CONTRACTOR immediately or at first notice given by COMPANY.
- 14.11** After the clean-up, the ROW of pastures has to remain fenced and to be removed during the maintenance period. When agricultural and other traffic (requested by tenant) have to cross the ROW the cross-overs have to be fenced with the same material as the ROW. If necessary, special materials have to be used to allow traffic on the cross-over. Fencing of the right-of-way as specified shall not be removed until CONTRACTOR has obtained written permission by COMPANY. In general, this has to be done during the maintenance period.
- 14.12** All openings in or damage to the fence or enclosures shall be repaired by installing new fencing of quality which shall be at least equal to the parts damaged or removed. Provisional gates shall be removed and replaced with new fencing. All repairs to fences and enclosures shall be carried out to the complete satisfaction of COMPANY, land owner and / or tenant.
- 14.13** If, in the opinion of COMPANY, the sod in pasture land has been damaged by vehicles and wheel tracks are visible, the ROW shall be tilled with a disc-harrow or rotary cultivator several times. The damaged sod shall be firmly cut up and thoroughly mixed through the top-soil. In general, the ROW has also to be ripped. After this procedure no closed-in layers must be found and sufficiently loose top-soil 25 to 30cm thick must be present. The whole procedure has to be approved by COMPANY, Subsequently, the entire ROW which is part of pasture land, shall be prepared for seeding and fertilized according to the instructions of COMPANY.
- 14.14** In crop fields the tillage shall consist of passing over the land several times with a disc harrow, cultivating with a spading machine, or plow, to a depth of approx. 20 cm. In general, the ROW has also to be ripped. After this cultivation process no closed-in layers must be found in the ROW. The equipment used and methods adopted shall require the approval of COMPANY. Ripping has to be done with rippers with a distance of 50cm between the ripper

	Laying, Installation, Testing and Commissioning of 8” dia. Steel gas pipeline connectivity in PATAN GA	
TENDER DOCUMENT NO REPL/SGL/STPL/009/22		Date: -06/12/2022

blades. The type to be used shall be approved by COMPANY.

14.15 A sampling of any plant/tree uprooted or cut during construction shall be planted along the route as per the direction of the COMPANY and in accordance with the Forest Preservation Act, 1981. The cost of sapling and its plantation shall be to CONTRACTOR’S account.

14.16 The ROW and the backfilled trench in particular have to be finished in such a way that after settlement of the soil the fields are at their original level.

If during the maintenance period certain parts of the ROW are lower than the original level, COMPANY can order CONTRACTOR to bring these parts to the original level. If the level of the ROW for clean-up is ordered by COMPANY, risk of above-mentioned additional restoration shall not be to CONTRACTOR’S account.

In cases where heavy damage has occurred to the structure of the subsoil as a result of special circumstances, COMPANY reserves the right to order CONTRACTOR to carry out special work. Said special work can include.

- spading with dragline (depth 30 – 80 cm)
- spading with dragline (depth 80 – 100 cm)
- fertilizing
- Cover with sand.



If during clean-up operations, soil shortages become apparent outside the trench, CONTRACTOR shall supplement said soil shortage using suitable materials, approved by COMPANY.

If site and / or climatic conditions should render this necessary, COMPANY shall have the right to order CONTRACTOR to suspend certain parts of the WORK related to the clean-up and postpone it to a later date.

14.17 Soil Surplus

If on site as a result of the work and after careful backfilling and compacting, a sub-soil surplus exists, this shall be worked up by grading and compacting below the sub-soil top layer and as a rule this shall be done in the same plot of land. It shall not be permitted to remove the surplus from the plot concerned, unless it concerns rejected soil which has to be removed. Working up surplus soil or removal of rejected soil shall be considered to pertain to the WORK.

To work a soil surplus into the ground CONTRACTOR shall remove an additional strip of top soil beside the trench. Next the upper layer of sub-soil shall also be removed. Both soil types shall be stored separately across a width depending on the size of the soil surplus. The soil surplus shall then be distributed across the trench thus widened, after which it shall be graded and compacted and subsequently the top layer of sub-soil and the top-soil shall be replaced in the correct order, in accordance with the Specifications.

	<p>Laying, Installation, Testing and Commissioning of 8” dia. Steel gas pipeline connectivity in PATAN GA</p>	
<p>TENDER DOCUMENT NO REPL/SGL/STPL/009/22</p>		<p>Date: -06/12/2022</p>

In case COMPANY has given prior permission for mixed excavation of the sub-soil as well as in cases where COMPANY deems mixed excavation permissible, the above provision of separate storage of the upper layer of sub-soil shall not apply to the working up of the soil surplus.

In cases where the soil surplus can be worked up in other plots. Where soil shortages have arisen due to the WORK, this shall only be done after prior permission by land- owner, land-user and COMPANY.

14.18 Soil Shortages.

If due to unforeseen circumstances during backfilling and compacting there isn't enough soil to fill the trench property, or to install the crown height as stipulated, CONTRACTOR shall supply the necessary backfill material.

Soil shortages shall be supplemented and applied before the top-soil is replaced.

The soil to be supplied shall be worked up in those locations and into those layers where a soil shortage has been established. The quality of the supplemented soil shall be equal to that of the shortage.

15.0 MAINTENANCE DURING DEFECTS LIABILITY PERIOD

Defects liability Period (defined as period of liability in the CONTRACT) means the period of 12 months calculated from the date certified in the Completion Certificate.

COMPANY reserves the right to carry out instrumented pigging survey of the completed pipeline.



CONTRACTOR shall be responsible for making good with all possible speed at his expense any defect in or damage to any portion of the Work which may appear or occur during the Defects liability Period and which arise either.

- a) from any defective material (other than supplied by COMPANY), workmanship or design (other than a design made, furnished or specified by COMPANY and for which CONTRACTOR has disclaimed responsibility in writing), or
- b) from any act or omission of CONTRACTOR done or omitted during the said period.

If such defect shall appear or damage occur, COMPANY shall forthwith inform CONTRACTOR thereof stating in writing the nature of the defect or damage.

If any such defect or damage be not remedied within a reasonable time, COMPANY may proceed to execute the work at CONTRACTOR'S risk and expense, provided that he does so in a reasonable manner, such defect or damage can be, but is not limited to.

- Clean up of ROW including water courses
- Sagging or sinking of site level or pipe supports.

	Laying, Installation, Testing and Commissioning of 8” dia. Steel gas pipeline connectivity in PATAN GA	
TENDER DOCUMENT NO REPL/SGL/STPL/009/22		Date: -06/12/2022

- Sliding of ditch banks
- Repair of fencing or removal of construction fencing.
- Repaving of pavements, repair of pavements, repair of coating painting.
- Realigning markers, signs.
- Leak/burst of pipe, leaking flanges, washouts.
- Short-circuit in casings.
- Construction defects such as dents, ovality, welding offsets/defects etc detected during intelligent pigging survey.
- Etc.

Company reserves the right to have the required computerized potential Logging Test executed during the DEFECTS LIABILITY PERIOD and whenever conditions are more favorable for this job. The work shall at or as soon as practicable after the expiration of the Defects Liability Period be delivered to COMPANY in the conditions required by the CONTRACT, fair wear and tear excepted to the satisfaction of COMPANY CONTRACTOR shall finish the work, if any outstanding, at the date of completion as soon as possible after such date and shall execute all such work.



**Laying, Installation, Testing and
Commissioning of 8” dia. Steel gas
pipeline connectivity in PATAN GA**



TENDER DOCUMENT NO
REPL/SGL/STPL/009/22

Date: -06/12/2022





Sabarmati Gas Ltd.
(A Joint Venture of GSPC and BPCL)

SABARMATI GAS LIMITED

**Laying, Installation, Testing and Commissioning of 8” dia. Steel gas
pipeline connectivity in PATAN GA**



RESONANCE ENERGY PVT. LTD.

**Specification for Welding of Pipelines
Tender No. REPL/SGL/STPL/009/22**

	Laying, Installation, Testing and Commissioning of 8” dia. Steel gas pipeline connectivity in PATAN GA	
TENDER DOCUMENT NO REPL/SGL/STPL/009/22		Date: -06/12/2022



CONTENTS

- 01 SCOPE
- 02 APPLICABLE CODES, STANDARDS & SPECIFICATIONS
- 03 MATERIAL SPECIFICATIONS
- 04 WELDING CONSUMABLES
- 05 EQUIPMENT & ACCESSORIES
- 06 WELDING PROCESSES
- 07 BEVEL CLEANING AND BEVEL INSPECTION
- 08 ALIGNMENT AND SPACING
- 09 WEATHER CONDITIONS
- 10 WELDING
- 11 HEAT TREATMENT
- 12 INSPECTION AND TESTING
- 13 REPAIR OF WELDS
- 14 DESTRUCTIVE TESTING
- 15 ULTRASONIC INSPECTION
- 16 RADIOGRAPHY

	<p>Laying, Installation, Testing and Commissioning of 8” dia. Steel gas pipeline connectivity in PATAN GA</p>	
<p>TENDER DOCUMENT NO REPL/SGL/STPL/009/22</p>		<p>Date: -06/12/2022</p>

CONTENTS

- Annexure-I Electrode Qualification Test Record
- Annexure-II Stress Relief Heat Treatment Procedure Specification
- Annexure-III Welding Procedure Qualification Test Record
- Annexure-V Welders Identification Card
- Annexure-VI Radiographic Procedure for Pipe Welding

	Laying, Installation, Testing and Commissioning of 8” dia. Steel gas pipeline connectivity in PATAN GA	
TENDER DOCUMENT NO REPL/SGL/STPL/009/22		Date: -06/12/2022

1. **SCOPE**

This specification stipulates requirements for fabrication of all types of welded joints in carbon steel piping systems covering the pipeline and its facilities, which will include the following.



- All line pipe joints of the longitudinal and circumferential butt welded and socket welded types.
- Branch connections
- Joints in welded / fabricated piping components.
- Attachments of castings, forgings, flanges and supports to pipes.
- Attachments of smaller connections for vents/drain pipes and toppings for instrumentation.

Note : Any approval accorded to the Contractor shall not absolve him of his responsibilities and guarantees.

2. **APPLICABLE CODES, STANDARDS & SPECIFICATIONS**

All welding works, equipment for welding, heat treatment, other auxiliary functions and the welding personnel shall meet the requirements of the latest editions of the following codes, standards and specifications as listed below.

- Code for Gas Transmission and Distribution Piping System(ASME B31.8).
- Standard for welding of Pipelines and Related Facilities (API1104).
- Specification for welding Electrodes and Filler Materials (ASME Sec. II C).
- API 1105 – Boiler on construction Practicum for oil and products Pipeline.
- ASME B31.4 – Pipeline Transportation systems for liquid hydrocarbons and other liquids.
- Part 19.2 title-4g – Transportation of Natural and other gas by pipeline (Department of Transportation pipeline safety standards).
- Part 19s – Transportation of liquids by pipeline (US Department of Transportation Pipeline Safety standards).

	Laying, Installation, Testing and Commissioning of 8” dia. Steel gas pipeline connectivity in PATAN GA	
TENDER DOCUMENT NO REPL/SGL/STPL/009/22		Date: -06/12/2022

- 0150141 – Design construction requirements for cross country hydrocarbon pipeline).
- Non-Destructive examination (ASME Sec. V)

3. **MATERIAL SPECIFICATIONS**

- In general carbon steel is used in this specification. The details of material specifications will be given in a welding Specification Chart attached along with other project data sheets.
- The CONTRACTOR will keep a record of test certificates of all the materials for the reference of the welding engineer.

4. **WELDING CONSUMABLES**

The electrode shall be suitable for the welding process recommended and base metal used. Physical properties of the welds produced by an electrode recommended for the welding of a particular base metal shall not be lower than the minimum values specified for the base metal unless otherwise specified in Welding Specification Chart and shall correspond to the physical properties of the class of electrode adopted. The choice of electrode shall be made after conducting the required tests on the electrodes as per relevant standards, and shall be the sole prerogative of the COMPANY.

The welding electrodes / Filler wires supplied by the CONTRACTOR shall conform to the class specified in the welding specification chart. The materials shall be of the make approved by the COMPANY.



The CONTRACTOR shall submit batch test certificates from the electrode manufactures giving details of physical and chemical tests carried out by them for each batch of electrode to be used.

Electrode Qualification test records shall be submitted as per Annexure-I with respect to the electrodes tested by the CONTRACTOR and submitted for approval of the COMPANY.

The CONTRACTOR shall provide at his own expenses all the welding consumables necessary for the execution of the job such as electrodes, oxygen, acetylene etc. and the same shall be approved in advance by the Purchaser / Consultant.

The electrodes used shall be free from rust, oil grease, earth and other foreign matter which affect the quality of welding.

All electrodes shall be purchased in sealed containers and stored properly to prevent deterioration. The electrodes removed from the containers (except cellulose coated electrodes) shall be kept in holding ovens at the temperature

	Laying, Installation, Testing and Commissioning of 8” dia. Steel gas pipeline connectivity in PATAN GA	
TENDER DOCUMENT NO REPL/SGL/STPL/009/22		Date: -06/12/2022

recommended by the electrode manufacturer.

Ovens shall be used for low hydrogen electrodes only. Out-of-the oven time of electrodes, before they are consumed, shall not exceed the limits recommended by the electrode manufacturer. The electrodes shall be handled with care to avoid any damage to the flux covering.

Different grades of electrodes shall be stored separately. Cellulose electrodes used shall however be used as per specific recommendations of manufacturer.

4.1 Shielding Gas

The composition and purity of shielding gas when required by the welding processes other than shielded metal arc (SMAW) welding, when permitted by the COMPANY, shall have prior approval of the COMPANY. Where appropriate, gases or gas mixture of the following quality shall be used.

- a) Argon compLAYING with BS 4365
- b) Carbon dioxide compLAYING with type 1 specified in BS 4105.
- c) Gas mixture that have been proved to be satisfactory as a result of procedure approval tests.



When a gas mixture is used which has specified additions, e.g. 2% 02.5% Co₂ the variation of such addition shall not exceed + 10% of that stated Moisture content shall correspond to a dew point of – 30⁰C or lower.

5. EQUIPMENT & ACCESSORIES

- 5.1 The CONTRACTOR shall have sufficient number of welding and cutting equipment, auxiliaries and accessories of sufficient capacities to meet the target schedule.
- 5.2 All the equipment for performing the heat treatment including transformers, thermocouples, pyre-meters, automatic temperature recorders with suitable calibration arrangements, etc. shall be provided by the CONTRACTOR, at his own expenses and these shall bear the approval of the COMPANY. Adequate means of measuring current and voltage shall be available.
- 5.3 Redoing of any work necessitated by faulty equipment or operation used by the CONTRACTOR, will be done at his own expense.

6. WELDING PROCESSES

- 6.1 Welding of various materials under this specification shall be carried out using Shielded Metal Arc welding process (SMAW) with the approval of the COMPANY.

	Laying, Installation, Testing and Commissioning of 8” dia. Steel gas pipeline connectivity in PATAN GA	
TENDER DOCUMENT NO REPL/SGL/STPL/009/22		Date: -06/12/2022

- 6.2 The welding processes to be employed are given in the welding specification chart. Any deviation desired by the CONTRACTOR shall be obtained through the express consent of the COMPANY.
- 6.3 Automatic process shall be employed only with the express approval of the COMPANY. The welding procedure adopted and consumables used shall be specifically approved.
- 6.4 A combination of different welding processes or a combination of electrodes of different classes / makes could be employed for a particular joint only after qualifying the welding procedures to be adopted and obtaining the approval of the COMPANY.

7. BEVEL CLEANING AND BEVEL INSPECTION

Line pipe supplied by COMPANY shall have bevel ends as specified in the applicable specification for Line pipe attached with the Bid Package. Any modification thereto, if required by CONTRACTOR due to his special welding technique shall be carried out by the CONTRACTOR at his own cost.



Before welding, all rust and foreign matter shall be removed from the beveled ends by power operated tools. This shall be affected inside and outside and for a minimum distance of 25mm from the edge of the weld bevel. The bevels shall be thoroughly inspected at this stage. If any of the ends of the pipe joints are damaged to the extent that, in the opinion of COMPANY, satisfactory weld spacing cannot be obtained and local repair by grinding cannot be successfully done, the damaged ends shall be cut and re-bevelled to the satisfaction of the COMPANY, with an approved beveling machine. Manual cutting and weld repairs of bevels is not allowed. Should laminations, split ends or inherent manufacturing defects in the pipe be discovered, the lengths of pipe containing such defects shall be removed from the line to the satisfaction of COMPANY.

Notches or laminations on pipe ends are not permitted and must be removed by cutting the pipe as a cylinder and re-beveling of pipes prior to welding.

On pipes which have been cut back, a zone extending 25mm back from the new field bevel, shall be ultrasonically tested to the requirement of the line pipe specification to ensure freedom from laminations. The new bevel shall be subjected to 100% visual and 100% dye penetrate / MPI tests. A report shall be written for all testing and records kept.

8. ALIGNMENT AND SPACING

Immediately prior to line-up CONTRACTOR shall inspect the pipe ends inside and outside for damage, dents, laminations etc. Pipe for welding shall be set up, correctly spaced, allowing for temperature changes during welding, in correct alignment and shall in no circumstance be sprung into position. Temporary attachments of any kind shall not be welded to the pipe. Welds joining the sections of the pipelines, valve installation or similar welds classified as tie-in

	Laying, Installation, Testing and Commissioning of 8” dia. Steel gas pipeline connectivity in PATAN GA	
TENDER DOCUMENT NO REPL/SGL/STPL/009/22		Date: -06/12/2022

welds shall be made in the trench. Otherwise the alignment and welding shall be made alongside the ditch with the pipe supported on skids and back pad or other suitable means approved by COMPANY, at least 500mm above the ground, unless approved by the COMPANY in specific cases.

Seam orientation of welded pipe shall be selected to ensure that at the circumferential welds, the longitudinal welds shall be staggered in the top 90 of the pipeline, or 250mm whichever is the lesser. A longitudinal joint shall pass an appurtenance of a structural element at a minimum distance of 50mm. should a section of the line containing uncompleted welds fall from the skids, the CONTRACTOR shall immediately inform COMPANY.

Every effort shall be made to reduce misalignment by the use of the clamp and rotation of the pipes to obtain the best fit. For pipe of same nominal wall thickness off-set shall not exceed 1.6mm. The offset may be checked from outside using dial gauges. Any branch connection, sleeve, etc. shall be at least 150mm from any other weld. The welds for fittings shall be so located that the toe of the cold dressing is permissible only in cases of slight misalignment and may only be carried out with a bronze headed hammer. Hot dressing shall not be permitted. When welding pipes of different wall thickness (as directed by COMPANY) as special transition piece shall be used. This shall have a minimum of 1:4 taper. The welds shall be subject to both ultrasonic and radiographic inspection.

The root gap shall be accurately checked and shall conform to the qualified welding procedure. The use of internal line-up clamps is mandatory for pipe diameters 10” and above. However, in some cases (tie-in welds, flanges, fittings, diameter of pipe 10” etc.) where it is impossible to use internal clamps an external line-up clamp may be used.

The internal line-up clamp shall not be released before the entire root pass has been completed.

When an external line-up clamp is used, all spaces between bars or at least 60% of the first pass shall be welded before the clamp is released and the pipe remaining adequately supported on each side of the joint.

Segments thus welded shall be equally spaced around the circumference of the pipe. Slag, etc. shall be cleaned of and the ends of the segments shall be prepared by grinding, so as to ensure continuity of the weld bead.

9. WEATHER CONDITIONS

The parts being welded and the welding personnel shall be adequately protected from rain and strong winds. In the absence of such a protection no welding shall be carried out. The completed welds shall be suitably protected in case of bad weather conditions.



Laying, Installation, Testing and Commissioning of 8” dia. Steel gas pipeline connectivity in PATAN GA



TENDER DOCUMENT NO
REPL/SGL/STPL/009/22

Date: -06/12/2022



10. WELDING

10.1 Root Pass

- a) Root pass shall be made with electrodes / filler wires reconvenedin the welding specification chart attached along with other project data sheets. The size of the electrodes used shall be as per the approved welding procedure.
- b) Position or roll welding may be permitted. Separate procedures shall be submitted and qualified for uphill, downhill, vertical down and roll welding. The vertical up method of welding shall be used for the root pass of the tie-ins, special crossings, fittings and special parts, filled welds, repairs and when an external line up clamp is used. The downhill welding may be used for root run welding of tie-ins and special crossings when (a) the edges are machined or have equivalent preparation (b) line up clamps are used and the fit up is geometrically and mechanically similar to one of the ordinary line welding without misalignment or unevenness.
- c) The root pass of butt joints shall be executed properly so as to achieve full penetration with complete fusion of the root edges. Weld projection inside the pipe shall not exceed 3mm wherever not specified by the applicable code.
- d) Any deviation desired from the recommended welding technique and electrodes indicated in the welding specification chart shall be adopted only after obtaining express approval of the COMPANY.
- e) Welding shall be continuous and uninterrupted during a pass.
- f) On completion of each run, craters, welding irregularities, slag, etc. shall be removed by grinding and chiseling.
- g) While the welding is in progress care shall be taken to avoid any kind of movement of the components, shocks, vibration and stresses to prevent occurrence of weld cracks.
- h) Fillet welds shall be made by shielded metal arc welding process irrespective of the thickness and class of piping. Electrode size shall not exceed 3.25mm diameter for socket joints. At least two passes shall be made on socket weld joint's.
- i) Preening shall not be used.

10.2 Joint Completion

In case of manual welding the first pass shall be carried out by a minimum of two welders, working simultaneously and so placed as to cause minimum

	Laying, Installation, Testing and Commissioning of 8” dia. Steel gas pipeline connectivity in PATAN GA	
TENDER DOCUMENT NO REPL/SGL/STPL/009/22		Date: -06/12/2022

distortion of the pipe.

The number of welders and the allowable welding sequences shall be as those laid down in the qualified welding procedure specification. One the deposit of the first pass has been started, It must be completed as rapidly as possible, reducing interruptions to the minimum. The welding and wire speed shall be approximately same as that established in the qualified welding procedure specification.

The pipe shall always be adequately supported and must not be pumped or shaken during welding. The clamp shall be removed, as indicated in as per Speciation clause 8.0 above. Before starting the second pass, the first pass shall be cleaned and attended with rotating grinders.

The interruption between completion of the first pass and starting the second pass shall be as stated in the procedure specification, normally not exceeding four minutes.



For crack prevention a top and bottom reinforcement of at least one electrode shall be applied before lowering the pipe on the skid.

The welding speed selected shall enable production of a bead which is sufficiently thick and which shows no undercutting.

The time lapse between second and third pass shall be as stated in the procedure specification, normally not exceeding five minutes. After completion of the third of following passes, welding operations may be suspended, so allowing the joint to call down, provided that the thickness of the weld metal deposited is equal to at least 50% of the pipe thickness of the weld metal deposited is equal to at least 50% of the pipe thickness. Upon restarting, depending on the materials, wall thickness and welding process, a preheating to at least 100°C shall be carried out. Subsequent passes up to weld completion shall be protected to avoid rapid cooling, if metrological conditions so dictate. Cleaning between passes shall be done carefully so as to reduce the possibility of inclusions.

Electrodes starting and finishing points shall be staggered from pass to pass. Arc-strikes outside the bevel on the pipe surface are not permitted. Arc-strike or Arc-burn on the pipe surface outside the weld, which are caused accidentally by electrical arcs between the electrodes, electrode holder, welding cable shall be removed by grinding in accordance with a procedure approved by COMPANY and the repair checked by ultrasonic, radiographic, magnetic particle or dye penetrant tests which the COMPANY feels necessary. The pipe wall thickness after grinding shall not be less that the minimum thickness limit permitted for the pipe. Repair of are-strikes by welding is prohibited.

The Completed weld shall be carefully brushed and cleaned and shall appear free from spatters, scales, etc.

	Laying, Installation, Testing and Commissioning of 8” dia. Steel gas pipeline connectivity in PATAN GA	
TENDER DOCUMENT NO REPL/SGL/STPL/009/22		Date: -06/12/2022

These requirements apply not only to completed welds but also to the bare strip at least so wide so as to allow full skid examination at both ends of the pipe to allow a good ultrasonic inspection when it is required.

11. **HEAT TREATMENT**

11.1 **Preheating**

- a) Preheating requirements for the various materials shall be as per the welding specification chart.
- b) Preheating shall be performed using resistance or induction / heating methods, Preheating by gas burners, utilizing acetylene or propane gas may also be carried out. Ox propane gas may be used with the permission of the COMPANY under careful supervision.
- c) Preheating shall extend uniformly to at least three times the thickness of the joint, but not less than 50mm, on both sides of the weld.
- d) Preheating temperature shall be maintained over the whole length of the joint during welding. Temperature indicating crayons or other temperature indicating devices shall be provided by the CONTRACTOR to check the temperature.

11.2 **Post weld Heat Treatment**

- a) Post weld heat treatment, wherever required for joints between pipes and fittings, pipe body and supports shall be carried out by the CONTRACTOR at his expense as per the relevant specifications, applicable standards and the instructions of the COMPANY.
- b) The heat treatment of welded joints shall be carried out as per the requirements laid down in ANSI B31.8 and other special requirements mentioned in welding specification chart.
- c) The CONTRACTOR shall submit for the approval of the COMPANY, well before carrying out actual heat treatments the details of the post weld heat treatment procedure, as per Annexure-II attached that he proposes to adopt for each of the materials/ assembly / part involved.
- d) Post weld heat treatment shall be done in a furnace or by using an electric resistance or induction heating equipment as decided by the COMPANY.
- e) While carrying out local post weld heat treatment, technique of application of heat must ensure uniform temperature attainment at all points of the portion being heat treated. Care shall be taken to ensure that width of heated band over which specified post weld heat treatment temperature is attained is at least as that specified in the relevant applicable



Laying, Installation, Testing and Commissioning of 8" dia. Steel gas pipeline connectivity in PATAN GA





TENDER DOCUMENT NO
REPL/SGL/STPL/009/22

Date: -06/12/2022

standards / codes.

The width of the heated band centered on the weld shall at least be equal to the width of weld plus 2" (50mm). The temperature gradient shall be such that the length of the material on each side of the weld, at a temperature exceeding half the heat treatment temperature, is at least 2.5 times where r is the bore radius and t is the pipe thickness at the weld.

- f) Throughout the cycle of heat treatment, the portion outside the heat band shall be suitably wrapped with insulation so as to avoid any harmful temperature ordained on the exposed surface of pipe. For this purpose temperature at the exposed surface of the pipe shall not be allowed to exceed 400^oc.
- g) The temperature attained by the portion under heat treatment shall be recorded by means of thermocouple pyrometers. Adequate number of thermocouples shall be attached to the pipe directly at equally spaced locations along the periphery of the pipe joint. The minimum number of thermocouples attached per joint shall be 2 up to 10" dia and 3 for 12" dia and above. However, the COMPANY can increase the required minimum number of thermocouples to be attached, if found necessary.
- h) Automatic temperature recorders which have been suitably calibrated shall be employed. The calibration chart of each recorder shall be submitted to the COMPANY prior to starting the heat treatment operation and its approval shall be obtained.
- i) Immediately on completion of the heat treatment, the post weld heat treatment charts/ records along with the hardness test results on the weld joints (whenever required as per the welding specification chart) shall be submitted to COMPANY for its approval.
- j) Each joint shall bear an identification number which shall be maintained in the piping sketch to be prepared by the CONTRACTOR. The joint identification number shall appear on the corresponding post weld heat treatment charts. The same Identification numbers shall also be followed for identification on corresponding radiographic films. The chart containing the identification number and piping sketch shall be submitted to the COMPANY in suitable folders.
- k) Vickers hardness/ Brunet hardness of the heat affected zone as well as of the weld metal, after heat treatment shall be measured using a suitable hardness tester and shall not exceed the maximum hardness specified in the welding specification chart. The weld joint shall be subjected to reheat treatment, when hardness measured exceeds the specified limit, at the CONTRACTOR's own expense.
- l) The CONTRACTOR shall arrange for the hardness testing and shall maintain the records of all the joints tested. These records shall be

	Laying, Installation, Testing and Commissioning of 8” dia. Steel gas pipeline connectivity in PATAN GA	
TENDER DOCUMENT NO REPL/SGL/STPL/009/22		Date: -06/12/2022

checked by the COMPANY.



12 INSPECTION AND TESTING

12.1 General

- a) The COMPANY’s Inspector shall have free access to all concerned areas, where the actual work is being performed. The CONTRACTOR shall be also provide the COMPANY’s inspector all means and facilities necessary to carry out inspection.
- b) The COMPANY is entitled to depute its own inspector to the shop or field where pre –fabrication and erection of pipelines are being done, with (but not limited to) the following objectives :-
 - i. To check the conformance to relevant standards / specifications and suitability of various welding equipment and be welding performance.
 - ii. To supervise the welding procedures qualification.
 - iii. To supervise the welder’s performance qualification.
 - iv. To carry out visual / NDT examination of the welding’s.
 - v. To check whether shop / field welding is being executed is in conformity with the relevant specification and codes of practice followed in pipe construction.
- c) CONTRACTOR shall intimate sufficiently in advance the commencement of qualification tests, welding works and acceptance tests, to enable the COMPANY’s inspector to be present to supervise the same.

12.2 Welding Procedure Qualification

- a) Welding procedure qualification shall be carried out in accordance with the relevant requirements of API 1104 latest edition or other applicable codes and other job requirements by the CONTRACTOR at his expense. The CONTRACTOR shall submit the welding procedure specification chart format as per Annexure- III (attached) immediately after the receipt of the order.
- b) COMPANY’S inspector will review, check and approve the welding procedure submitted and shall release the procedure for procedure qualification tests. The procedure qualification test shall be carried out by the CONTRACTOR under field conditions at his own expense. A complete set of test results in format as per Annexure-III (attached) shall be submitted to the COMPANY’s Inspector for approval immediately

	Laying, Installation, Testing and Commissioning of 8” dia. Steel gas pipeline connectivity in PATAN GA	
TENDER DOCUMENT NO REPL/SGL/STPL/009/22		Date: -06/12/2022

after completing the procedure qualification test and at least 2 weeks before the commencement of actual work. Standard test as specified in the code shall be carried out in all cases. In addition to these, tests, other tests like radiography, macro / micro examination, hardness tests, dye penetrate examination, Charpy V-notch etc. shall be carried out on specimens. It shall be the responsibility of the CONTRACTOR to carry out all the tests required to the satisfaction of the COMPANY's Inspector. The destructive testing of welded joints shall be as per Clause 14.0.

12.3 Welder's Qualification

- a) Welders shall be qualified in accordance with the API 1104 and other applicable specifications by the CONTRACTOR at his expense. His qualification shall include toughness testing requirements as applicable for the line pipe. The butt weld test pieces of the qualification test shall meet the radiographic test requirements specified in Clause 12.5 and 16.0 of this specification. The welder qualification shall be done only on project plant pipe. The COMPANY's Inspector shall witness the test and certify the qualification of each welder separately. Only those welders who have been approved by the COMPANY's Inspector shall be employed for welding. CONTRACTOR shall submit the welder qualification test reports in the standard format as shown in Annexure-IV and obtain express approval, before commencement of the work. It shall be the responsibility of CONTRACTOR to carry out qualification tests of welders.
- b) The welders shall always have in their possession the identification card as shown in Annexure-V and shall produce it on demand by the COMPANY's Inspector. It shall be the responsibility of the CONTRACTOR to issue the identity cards after it has been duly certified by the COMPANY.
- c) No welder shall be permitted to work without the possession of identity cards.
- d) If a welder is found to perform a type of welding or in a position for which he is not qualified, he shall be debarred from doing any further work. All welds performed by an unqualified welder shall be cut and redone by a qualified welder at the expense of the CONTRACTOR.

12.4 Visual Inspection

Inspection of all welds shall be carried out by COMPANY as per the latest editions of the applicable codes and specifications. All finished welds shall be visually inspected for parallel and axial alignment of the work, excessive reinforcement, concavity of welds, shrinkage, cracks, under-cuts, dimensions of the weld, surface porosity and other surface defects. Undercutting adjacent to the completed weld shall not exceed the limits specified in the applicable standard/code.



Laying, Installation, Testing and Commissioning of 8” dia. Steel gas pipeline connectivity in PATAN GA



TENDER DOCUMENT NO
REPL/SGL/STPL/009/22

Date: -06/12/2022

12.5 Non-Destructive Examination

The non-destructive examination shall mainly consist of examination using x-ray, Gamma-ray radiography as detailed in Clause 16.0 Radiographic examination of one hundred percent (100%) girth welds will be required by the COMPANY. In case of radiography is not possible due to safety reasons, weld shall be examined by using ultra sonic techniques. Prior Approval shall be taken from SGL.

For 150# Rating Pipeline, welds shall meet the standards of acceptability as set forth in API 1104. However for higher class rating pipeline welds shall meet the standards of acceptability as set forth in API 1104 and as well as the requirements laid in subsequent paragraphs.



The CONTRACTOR shall make all the arrangements for the radiographic examination of work covered by the specification at his expense.

The COMPANY will review all the radiographs of welds and inform the CONTRACTOR regarding acceptable welds. The decision of the COMPANY shall be final binding in the regard.

- I Any length of inadequate penetration of the root bead as defined by API 1104 is not acceptable except that root concavity is allowed as per API 1104.
- II Any amount of incomplete fusion at the root of the joint as detailed in Para 6.3.4 of API 1104 sixteenth edition May, 1983 (Ref. Fig. 13) is considered unacceptable.
- III Unprepared burn through areas is unacceptable.
- IV No root crack shall be permitted.

All requirements mentioned in the specification shall be arranged and executed by the CONTRACTOR through his own resources. In addition, for pipes with wall thickness 9.5mm and above, ultrasonic inspection is required in the following cases as per clause 15.0 of this specification.

- a) On the first 100 welded joints corresponding to each automatic (GTAW / GMAW) welding procedure used.
- b) When 20mm or more are cut from the pipe end as supplied, the ends shall be ultrasonically inspected for an additional length of 20mm to assure no lamination exist.
- c) When welds are repaired.

	Laying, Installation, Testing and Commissioning of 8” dia. Steel gas pipeline connectivity in PATAN GA	
TENDER DOCUMENT NO REPL/SGL/STPL/009/22		Date: -06/12/2022

- d) When in the opinion of COMPANY, ultrasonic inspection is required to confirm or clarify defects indicated by radiography.
- e) When automatic procedure is used at least 10 cm on each weld shall be ultrasonically inspected at COMPANY’s discretion.

In addition, ultrasonic inspection may be required for certain critical welding of the pipeline (i.e., tie-ins, welding of valves, flanges) randomly selected at COMPANY’s discretion. All fillet and groove welds other than the radiography shall be subjected to dye penetrate / MP inspection. The non-destructive test system used for inspecting welds must be approved by the COMPANY.

Weld quality is judged on the basis of the acceptability criteria mentioned below.

Any weld which as a result of radiographic and /or ultrasonic examination in the opinion of COMPANY exhibits imperfections greater than the limits stated in API-1104 latest edition or as superseded in this article shall be considered defective and shall so be marked with an identification paint marker.

In addition to the API-1104 requirements, the welds containing cracks including crater cracks regardless of size of location is unacceptable.



1. Any length of inadequate penetration of the root bead as defined by API-1104 is not acceptable except that root concavity is allowed as per API-1104.
2. Any amount of incomplete fusion at the root of the joint as detailed in API – 1104 is considered unacceptable.
3. Unprepared burns through areas are unacceptable.

Suitable records shall be maintained by the CONTRACTOR as desired by the COMPANY on the day-to-day work done on welding, radiography, ultrasonic testing. The CONTRACTOR shall present the records to the COMPANY on day-to-day basis and whenever demanded, for approval.

12.6 Destructive Testing

The COMPANY has the authority to order the cutting or upto 0.1% of the total number of welds completed for destructive testing at no extra cost of COMPANY. The destructive testing of weld joints shall be made as per Clause 14.0.

In addition, welds already cut out for defects for any reason may also be subjected to destructive testing. The sampling and the re-execution of welds shall be carried out by the CONTRACTOR at his own expense. If the results are unsatisfactory, welding operations shall be suspended and may not be restarted until the causes have been identified and the CONTRACTOR has adopted

	Laying, Installation, Testing and Commissioning of 8” dia. Steel gas pipeline connectivity in PATAN GA	
TENDER DOCUMENT NO REPL/SGL/STPL/009/22		Date: -06/12/2022

measures which guarantee acceptable results. If it is necessary in the COMPANY's opinion the procedure shall be re-qualified. The weld joint represented by unsatisfactory welds shall stand unless investigation proves otherwise.

13 REPAIR OF WELDS

13.1 With the prior permission of COMPANY, welds which do not comply with the standards of acceptability shall be repaired or the joint cut out and re-welded.

Welds having defects shall be removed or repaired in accordance with API 1104 or ASME Boiler and Pressure Vessel (BPV) code section IX as applicable.

A separate welding procedure specification sheet shall be formulated and qualified by CONTRACTOR for repair welds simulating the proposed repair to be carried out. Separate procedures are required to be qualified for (a) thorough thickness repair (b) external repair and (c) internal repair. Welders shall be qualified in advance for repairs and in accordance with “Qualification and Procedures of Welders”. The root pass, for repairs opening the root, shall be done by the vertical up technique. The procedure shall be proven by satisfactory procedure tests to API 1104 including the special requirement of the specification, and shall also be subject to metallographic examination, hardness surveys and Charpy tests to determine the effects of repair welding on the associated structure.



Root sealing or single pass repair deposit shall not be allowed. Internal root defects shall be ground thoroughly and welded with a minimum of two passes. However, while grinding for repairs, care shall be taken to ensure that no grinding marks are made on the pipe surface anywhere. The repair shall be subjected, as a minimum requirement to the same testing and inspection requirements as the original weld. The re-radiography of repaired weld shall be limited to 6” weld length on either edge of the repaired area. A 100% ultrasonic test shall be done at the repaired area externally. Any repaired area that is wide, irregular or rough shall be rejected and full cut out shall be done. The repair welding shall have a minimum preheat of 100⁰C and shall be preheated for at least 150mm on either side of repair only low hydrogen electrodes shall be used for repair of Welds.

Repairs are limited to a maximum of 30% of the weld length. Welds not meeting the specification after one repair shall be cut out depending upon the extent of repair. A report of all repairs shall be maintained by CONTRACTOR.

13.2 Limitations on Repairs

Only One attempt at repair of any region is permitted. Repairs are limited to a maximum of 30% of the weld length measuring over cap. Welds containing cracks shall be cut out and re bevelled to make a joint.

13.3 Weld Rejected by Accumulation of Defects.

	Laying, Installation, Testing and Commissioning of 8” dia. Steel gas pipeline connectivity in PATAN GA	
TENDER DOCUMENT NO REPL/SGL/STPL/009/22		Date: -06/12/2022

Where a weld is rejected by the accumulation of defect clause, as defined by API 1104 and this specification, repairs within these limitations are permitted. Defects in the filling and capping passes shall be repaired preferentially.

13.4 Acceptance criteria for welding procedure qualification & their testing, welder qualification & their testing and non-destructive examination of welded joints shall be as per API-1104 (Latest Edition).

13.5 Same Criteria as mentioned above shall also be applicable for aboveground piping system.

14. DESTRUCTIVE TESTING OF WELDED JOINT – BUTT WELDS

Preparation

Having passed the visual and the non – destructive – inspection the testweld shall be subject to mechanical test.

After satisfactory completion of all visual and non-destructive testing the test weld shall be set aside for a period not less than 24hours. No further work on the test weld and no cutting of test specimens from the weld shall be performed until a period of at least 24 hours has expired.

Weld specimens shall be taken from the positions as per approved WPS for this reason it is necessary to take the previous non-destructive tests into account. The minimum number of tests to be carried out is given in Table-1 of this specification

The tests shall be carried out in laboratories approved by the COMPANY. The specimens shall be prepared in accordance with the figures given in the paragraphs which refer to the individual tests.

Tensile strength

Specimens shall be taken from the position as per approved WPS. The test shall be carried out in accordance with API 1104 Acceptance Criteria shall be as per API 1104.

14.2.1 Method

The test shall be carried out in accordance with ISO : 375



 Sabarmati Gas	Laying, Installation, Testing and Commissioning of 8” dia. Steel gas pipeline connectivity in PATAN GA	 Resonance Energy
TENDER DOCUMENT NO REPL/SGL/STPL/009/22		Date: -06/12/2022

Table-1

Type and Number of Test Specimens for Procedure Qualification Test & production Welds

Pipe size. Out side Diameter-Inches	Number of Specimens									
	Tensile API	Tensile ISO	Nick Break	Root Bend	Face Bend	Side Bend	Macro Bend	Hardness	Impact	Total
Wall Thickness- 1/2 inch (12.7mm) and under										
Under 2-3/8	0	0	2	2	0	0	0	0	0	4
2- 3/8 to 4- 1/2 Incl.	0	0	2	2	0	0	0	0	0	4
Over 4- 1/2 less than 12.75	2	0	2	2	2	0	2	2	12	24
12 – 3/4 and over	2	2	4	4	4	0	2	2	24	44
Wall Thickness – Over 1/2 Inch (12.7mm)										
4 – 1/2 and smaller	0	2	0	0	0	2	0	0	0	4
Over 4 – 1/2 Less than 12- 3/4	2	0	2	2	2	0	2	2	12	24
12 – 3/4 and over	2	2	4	0	0	8	2	2	24	44

14.3 Nick – Break Test

14.3.1 Preparation



Specimens for Nick-break test with notched thus worked can break in the base metal, instead of in the fusion zone; therefore an alternative test piece may be used after authorization by the COMPANY with a notch cut in the reinforcement of outside weld bead to a maximum depth of 1.5m measured from the surface of the weld bead.

14.4 Macroscopic Inspection

14.4.1 Preparation

Specimens shall be taken from the positions as Indicated in the approved WPS and shall be prepared in accordance with ASTM E2 and E3.

The width of the macro section has to be at least three times the width of the weld. The section is to be prepared by grinding and polishing and etched to clearly reveal the weld metal and heat affected zone.

	Laying, Installation, Testing and Commissioning of 8” dia. Steel gas pipeline connectivity in PATAN GA	
TENDER DOCUMENT NO REPL/SGL/STPL/009/22		Date: -06/12/2022

14.4.2 Method

Specimens shall be carefully examined under the microscope, with a magnification of at least 25 times (25:1). The COMPANY may ask for a macrograph with 5 times (5:1) magnification for DOCUMENTATION purposes.

14.4.3 Requirements

Under macroscopic examination, the welded joints shall show good penetration and fusion, without any defect exceeding the limits stated in the evaluation criteria of the nick break test.

14.5 Hardness Test

14.5.1 Preparation

The prepared macro section is to be used for hardness testing using the Vickers method with 10kg load. Indentations are to be made along traverses each approximately 1mm below the surface on both sides of the weld.

In the weld metal a minimum of 6 indentations equally spaced along the traverses are to be made. The HAZ indentations are to be made along the traverses for approximately 0.5 mm each into unaffected materials, and starting as close to the fusion line as possible.

One indentation on each side of the weld along each traverse is to be made on parent metal. Refer Fig. 3. The indentations are to be made in the adjacent regions as well on the opposite sides of the macro section along the specified traverses.

14.5.2 Method

The test shall be carried out in accordance with Recommendation ISO R81, Vickers hardness, using a laboratory type machine controlled as per recommendation ISO R 146 and using a diamond pyramid penetrator set at 2.37 red (136⁰) with a load of 10 Kg.

14.5.3 Requirements

Hardness value shall not exceed the limit specified in welding Specification chart. In case of a single reading having a slightly (+10 HV) higher value than the specified limit, further indentations shall be made to check if the high value was an isolated case.

All the hardness values contained from the heat affected zone shall not exceed 100 HV with respect to the average hardness of the values obtained for the base metal. If these additional tests give hardness within the specification limit the slightly higher value may be accepted.



Laying, Installation, Testing and Commissioning of 8” dia. Steel gas pipeline connectivity in PATAN GA



TENDER DOCUMENT NO
REPL/SGL/STPL/009/22

Date: -06/12/2022

14.6 Charpy V – Notch Impact Test

14.6.1 Specimens shall be taken from the position as per approved WPS. The test specimens will be prepared in accordance with ASTM-370 Charpy V- notch Specimens shall have dimensions as given in Fig. 3 of this specification.

Five test specimens shall be taken from each sample and they shall be cut and worked so that their length is transverse and perpendicular to the weld bead with the notch position as per approved WPS. The notch shall be perpendicular to the roller surface. The test specimen width shall depend upon the pipe wall nominal thickness as following :

Sl. No.	Nominal Wall Thickness in mm.	Test Specimen width mm
1.	Over 12	10
2.	Over 9.5 and up to 12	7.5
3.	From 7 up to 9.5	5
4.	Less than 7	2.5

14.6.2 Test Method



The test shall be carried out as indicated in ASTM-370 “Beam impact test V-notch”.

Test pieces shall be immersed in a thermostatic bath and maintained at the test temperature for at least 15 minutes. They shall then be placed in the testing machine and broken within 5 seconds of their removal from the bath. The test temperature shall be as mentioned in Special conditions of the Contract.

14.6.3 Requirements (Note-1)

The impact energy shall be :

Sl No.	Test Specimen	Average of three Specimens (Note-2)	Minimum Single Value (Note-1)
	In mm	Joules (Min.)	Joules
1.	10.0	27.0	22.0
2.	7.5	21.5	17.0
3.	5.0	18.5	15.0
4.	2.5	10.00	8.0

	Laying, Installation, Testing and Commissioning of 8" dia. Steel gas pipeline connectivity in PATAN GA	
TENDER DOCUMENT NO REPL/SGL/STPL/009/22		Date: -06/12/2022

Note :

- 1) Only one value is permitted to be lower than average value up to the value specified.
- 2) These value are specified for resistance to brittle fracture only. Where additional requirements are specified in project data sheet. (Ex. Pipeline materials with arrest properties i.e. a higher upper shelf charpy V-energy for resistance against propagating ductile fractures) the same shall be followed.

14.7 Bend Test Requirements

The Bend test Specimens shall be made and tested as per the requirements of API 1104 Sixteenth Edition May 1983 except that the dimensions of the Jig for guided bend test Fig. 5 para 2.6 API 1104 shall be modified as follows :

Radius of the Plunger „A“	:	2t
Radius of the die „B“	:	3t + 1.6mm
Radius of the die „C“	:	50.8mm

The acceptance criterion on shall however be as per para 2.643 and 2.653 of API 1104 Eighteenth edition May 1994.

Note : t = thickness of specimen.

15. ULTRASONIC INSPECTION

In addition to the radiographic inspection, ultrasonic inspection is required as per conditions listed in paragraph 12.5 of this specification. This section concerns manual ultrasonic inspection. However ultrasonic by automatics equipment may be used if approved by the COMPANY.

15.1 Equipment and Operators

The CONTRACTOR who carries out the ultrasonic inspection shall have sufficient qualified personnel equipment and instruments at his disposal to be able to affect the tests without hindering or delaying the pipeline assembly operations.

The operators shall be fully qualified as per a recognized standard (ASME Sec.V or equivalent) and they shall have as minimum level it. The operators shall be able to:



Laying, Installation, Testing and Commissioning of 8” dia. Steel gas pipeline connectivity in PATAN GA



TENDER DOCUMENT NO
REPL/SGL/STPL/009/22

Date: -06/12/2022

- Calibrate the equipment;
- Perform an operational test under production conditions;
- Interpret the screen picture;
- Evaluate the size and location of reflectors
- Interpret the type of defects detected.

The COMPANY has the option of checking the ability of personnel employed for ultrasonic testing by means of qualification tests.

The CONTRACTOR appointed to carry out ultrasonic inspection shall supply all the instruments necessary for their execution on site.

15.2 Specification for Ultrasonic Inspection Procedure Qualification

Before work begins, the CONTRACTOR shall present a specification describing the proposed U.T. procedure qualification.

This specification shall state, as an indication only but not limited to the following information:

- Type of U.T. equipment used.
- Type and dimensions of transducers
- Frequency range
- Details for calibration
- Coupling medium
- Inspection technique
- Record details
- Reference to the welding procedure where it is intended to adopt the specification.
- Temperature range of the joints to be inspected.

15.3 Qualification of Ultrasonic Inspection Procedure



The ultrasonic Inspection procedure shall be approved by the COMPANY. Before inspection begins, the COMPANY may require the qualification test of the ultrasonic inspection procedure. This specification test consists in testing (under normal operation conditions) some CONTRACTOR welds made according to the same production procedure, where there are typical defects the test intends to detect.

This test shall be conducted in the presence of the COMPANY.

15.4 Test Procedure

Circumferential welds shall be inspected from both sides using angled probes.

The surface with which the probes come into contact shall be free of metal spatter, dirt, iron oxide, and scales of any type; therefore it shall be necessary to

	Laying, Installation, Testing and Commissioning of 8” dia. Steel gas pipeline connectivity in PATAN GA	
TENDER DOCUMENT NO REPL/SGL/STPL/009/22		Date: -06/12/2022

clean a strip at least 50mm wide on both sides of the weld with steel wire brushes and anyhow the cleaned strip must be at least wide enough to allow full skip examination.

If, during the test, echoes of doubtful origin appear, it shall be necessary to inspect a convenient area on the pipe surface, close to the weld, with a straight beam transducer in order to check whether any manufacturing defects are present which could have interfered with the ultrasonic beam.

By way of an example, the equipment shall include but not be limited to the following:

- Ultrasonic equipment and coupling medium
- Sample sections for calibration of instruments.
- Equipment for cleaning of surface to be examined.
- Rules calibrated in centimeters for exact location of the position of defects.

The characteristics of the above – listed instruments and equipment shall guarantee.

- a) that the required standards of the inspection procedure, as previously established and approved by the COMPANY, are satisfied.
- b) Continuous operation

All the instruments and equipment shall be approved by the COMPANY before being used. The COMPANY has the authority to reject any item which is considered unsuitable. The decision of the COMPANY is final. The CONTRACTOR appointed to carry out ultrasonic inspections shall also ensure the operational efficiency and maintenance of the instruments and equipment, and shall immediately substitute any item rejected by the COMPANY.

All the instruments and equipment necessary for carrying out ultrasonic inspection on site shall satisfy the requirements laid down by the public boards of institutions which regulate „safety at work“.

15.5 Ultrasonic Instruments.

The Ultrasonic Instruments shall satisfy the following..

- Be pulse type, able to generate, receive and display, on the screen a cathode ray tube (CRT) pulse at frequencies between 1 and 6 MHz. The useful part of the CRT screen shall be at least 70mm wide and at least 50mm high.



Laying, Installation, Testing and Commissioning of 8" dia. Steel gas pipeline connectivity in PATAN GA



TENDER DOCUMENT NO
REPL/SGL/STPL/009/22

Date: -06/12/2022

- Shall have variable amplification, with steps of 1 or 2 dB over a range of at least 60dB.
- The regulation control shall be accurate to within +1 db and this accuracy shall be certified by the instrument manufacturer.
- May be powered by a battery or an electric generator. In the first case, the autonomy of operation (endurance) of the instrument shall be sufficient to carry on working without frequent interruptions, and the instruments shall be equipped with an automatic switch which switches it off when the battery runs down; in the second case there must be a voltage stabilizing device with a tolerance of +2 Volts.

15.6 Probes

The probes used shall have dimensions, frequencies, and a refraction angle suited to the type of steel, the diameter, the thickness of the pipe and to the joint design.

15.7 Reference Sample Pieces

The efficiency of the equipment used, the effective refraction angle of the probe, and the beam output point, shall be checked using a V_1 and V_2 sample block, IIW type or calibration block ASTM E-428.

For the calibration of runs and the regulation of detection sensitivity during the test, a calibration piece shall be used. This piece shall be taken from the production material, and will be least 150mm long (measured in the direction of the axis), and at least 50mm wide (measured in the direction of the circumference) (see Fig. 4 of this specification).



In the middle of the inside and the outside surface of the calibration piece a groove shall be made. The groove will have a rectangular cross section, a flat bottom and the following dimensions.

- Depth : 1 ± 0.1 mm
- Breadth (measured parallel to the 150mm side) : 1 ± 0.1 mm
- Length (measured parallel to the 50mm side) not less than 30mm

In addition, the calibration piece shall have a hole, 2mm in diameter, passing through its thickness and positioned so that during calibration the echoes returning from the two grooves do not interfere with those returning the hole.

15.8 Calibration

For a precise check of the sound paths necessary for a full inspection of the weld

	Laying, Installation, Testing and Commissioning of 8” dia. Steel gas pipeline connectivity in PATAN GA	
TENDER DOCUMENT NO REPL/SGL/STPL/009/22		Date: -06/12/2022

joint, the probe shall be moved (half skip and full skip distance) until internal and external notches on the test piece are detected (See Fig. 5 of this specification).

The relevant defect limits the path lengths on the time base. The calibration of reference sensitivity is obtained by utilizing the through – drilled test hole in the thickness of the reference block to draw the distance – amplitude correction curve relevant to the test probe.

Calibration shall be carried out according to the following procedure ; place its internal vertex until the maximum height of echo is displayed on the screen; this echo is adjusted to 80% of full screen height by means of the sensitivity adjuster set in dB. Without varying the amplification, the probe placed at full skip distance from the hole is moved to detect the external vertex of the hole until the maximum height of echo is obtained. The straight line connecting the peaks of the two echoes obtained by the above procedure, represents 100% reference level, while the one connecting the two points at half height of the same echoes represents “50% reference level”.

The two straight lines shall be marked on the screen with a pen. Calibration shall be repeated each time tests are re-started; at intervals not longer than 30 minutes during normal operations; each time the conditions fixed in advance are altered. This calibration is applicable provided that the crystal of the probe is 8 x 9mm size. Should this size of the crystal be different, the value of the sensitivity obtained from the calibration by a crystal of a different, the value of the sensitivity obtained from the calibration by a crystal of a different size shall be brought to the value of sensitivity obtained from the calibration by a 8 x 9 mm crystal. The sensitivities of the two different size probes shall be compared through the echoes obtained on the notch of the test piece with the probe position at half skip of the distance.

15.9 Regulation of Amplification During Production Testing

The amplification during production testing shall be obtained by adding 2-6 dB (according to the surface condition of the pipe and its cleanness) to the reference amplification.



15.10 Qualification of Ultrasonic Testing Operators

Before the inspection begins or during the same inspection, the COMPANY may require a qualification test for the ultrasonic equipment operators.

15.11 Evaluation of Indications Given by Ultrasonic Tests

Each time that echoes from the weld bead appear during production testing, the instrument amplification shall be altered to coincide with the reference amplification and the probe shall be moved until maximum response is obtained, paying attention all the time of the probe – tube coupling.

If, under these conditions, the height of the defect echo is equal to or greater than

	Laying, Installation, Testing and Commissioning of 8” dia. Steel gas pipeline connectivity in PATAN GA	
TENDER DOCUMENT NO REPL/SGL/STPL/009/22		Date: -06/12/2022

that of the reference echo, the defect shall be evaluated according to other clauses of this Specification. If the defect has also been detected by the radiographic and or visual examination, the dimensions shall be judged according to the type of examination which detects the greater defect. Returns which are less than 50% of the reference echo, will not be considered. If returns are above 50% but lower than 100% of the reference echo, and if the operator has good reasons to suspect that the returns are caused by unfavorably oriented cracks, the same shall be informed to the COMPANY. Moreover, when there is a defect to be repaired, such defect shall be removed for a length corresponding to the one where no more return echo is given.

15.12 **Other Equipment**

The use of rules calibrated in centimeters, attached if possible to the probe, for the precise location of the position of welding defects, is recommended. Defect location is effected by measuring the projection distance between the probe output and the reflecting surface.

The operators carrying out the tests shall have besides the probing instrument, tools for cleaning the pipe surface (files, brushes, etc.) as well as, the coupling liquid or pasts appropriate for the temperature of the section to be examined.

16. **RADIOGRAPHY**

16.1 **Scope**

This covers the radiographic inspection of all types of welded joints of the main pipeline.

The welded joints shall include the following :-

- I Full girth welds on the mainline construction including doublejointing of pipe, if adopted.
- II Welds for installation of block valves, insulation joints and other appurtenances and tie-ins.
- III Welds at scraper launching and receiving barrels.
- Iv Terminal Piping

16.2 **Applicable Standards**

This specification shall apply in conjunction with the following (all latest editions).

- I API 1104, Standard for welding Pipelines and Related facilities.
- II ANSI B31.8, Code for Gas Transmission and Distribution Piping Systems



Laying, Installation, Testing and Commissioning of 8” dia. Steel gas pipeline connectivity in PATAN GA



TENDER DOCUMENT NO
REPL/SGL/STPL/009/22

Date: -06/12/2022

- III ANSI B31.4 Code for Liquid Petroleum Transportation Piping Systems.
- IV ASTM E94, Recommended practice for Radiographic Testing.
- V ASTM E142, Standard Method for Controlling Quality of Radiographic Testing.
- VI The American Society for Non-destructive Testing.

Recommended Practice No. SNT – TC – 1A Supplement A.

16.3 Procedure

16.3.1 The radiographic examination procedure to be adopted shall be submitted by the CONTRACTOR as per Annexure – VI.

16.3.2 The procedure of radiographic examination shall be qualified to the entire satisfaction of COMPANY prior to use. It shall include but not be limited to the following requirements:

- I Lead foil intensifying screens, at the rear of the film shall be used for all exposures.
- II Type 2 and 3 films as per ASTM E-94 shall be used.
- III A densitometer shall be used to determine film density. The transmitted film density shall be 2.0 and 3.5 throughout the weld. The unexposed base density of the film shall not exceed 0.30.
- IV Radiographic identification system and documentation for radiographic interpretation reports and their recording system.

16.3.3 The CONTRACTOR shall qualify each procedure in the presence of the COMPANY prior to use.

16.3.4 The procedure of radiographic examination shall produce radiographs of sufficient density, clarity and contrast so that defects in the weld or in the pipe adjacent to the weld, and the outline and holes of the penetrometer are clearly discernible.

16.3.5 All the girth welds of mainline shall be subjected to 100% radiographic examination. The CONTRACTOR shall furnish all the radiographs to the COMPANY, immediately after processing them, together with the corresponding interpretation reports on approved format. The details of the radiographs all along with the joint identification number shall be duly entered in a register and signed by the CONTRACTOR and submitted to the COMPANY for approval.

16.3.6 When the radiation source and the film are both on the outside of the weld



Laying, Installation, Testing and Commissioning of 8" dia. Steel gas pipeline connectivity in PATAN GA



TENDER DOCUMENT NO
REPL/SGL/STPL/009/22



Date: -06/12/2022

and located diametrically opposite each other, the maximum acceptable length of film for each exposure shall not exceed the values given in Table-4 of API 1104. The minimum film overlap, in such cases, shall be 40mm. The ellipse exposure technique may be used on nominal pipe sizes of 2 inch and smaller provided that the source of film distance used is a minimum of 12 inch.

- 16.3.7 Three copies of each acceptable radiographic procedure (as per Annexure-VI) and three copies of radiographic qualification records shall be supplied to COMPANY. One set of the qualifying radiographs on the job shall be kept by the CONTRACTOR's authorized representative to be used as a standard for the quality of production radiographs during the job. The other two sets shall be retained by COMPANY for its permanent record.
- 16.3.8 Three copies of the exposure charts relating to material thickness, kilo voltage, source of film distance and exposure time shall also be made available to COMPANY by the CONTRACTOR.
- 16.3.9 The CONTRACTOR shall, on a daily basis, record for each radiograph (1) radiograph's number, (2) welder's number (3) approximate chainage of weld location, (4) whether or not the welds meet the specified acceptance standards and (5) the nature and approximate location of unacceptable defects observed. It must be possible to relate back to a particular butt weld and welder on piping drawing and pipe line alignment drawing.
- 16.3.10 Each day's production of processed radiographs shall be properly packaged separately, identified by at least the (1) date, (2) radiographic Unit, (3) job locations, (4) starting and ending progress survey stations and (5) shall include original and three copies of the daily radiographic record. The package shall be submitted to the COMPANY daily when possible, but in no event later than none of the following day.
- 16.3.11 The CONTRACTOR shall provide all the necessary facilities at site, such as a dark room with controlled temperature, film viewer etc. to enable the COMPANY to examine the radiographs.
- 16.3.12 The CONTRACTOR, If found necessary, may modify the procedure of radiographic examination suiting to the local conditions prevailing. This shall, however, be subject to the approval of the COMPANY.
- 16.3.13 COMPANY shall have free access to all the CONTRACTOR's work facilities in the field.
- 16.3.14 Any approval granted by the COMPANY shall not relieve the CONTRACTOR of his responsibilities and guarantees.

16.4 Radiation Sources

- 16.4.1 Radiographic examination shall be carried out using x –radiations, Radiographic

	Laying, Installation, Testing and Commissioning of 8” dia. Steel gas pipeline connectivity in PATAN GA	
TENDER DOCUMENT NO REPL/SGL/STPL/009/22		Date: -06/12/2022

examination by Gamma rays may be allowed, at the discretion of the COMPANY, in case of inaccessible joints. Radiography by Gamma – Ray for tie-in joints shall be acceptable provided D4 AGFA film or equivalent is used and the required sensitivity obtained.

16.4.2 Whenever possible, pipeline welds will be inspected by placing the radiation source inside the pipe, on the pipeline axis, with a radiation of 6.28 rad. (360⁰C).

If it is impossible to place the radiation source inside the pipe, the weld will be inspected with the source on the outside. An overlap of at least 40mm at the ends of each film shall be required to ensure that the first and last location increment numbers are common to successive films and to establish that no part of a weld has been omitted.

16.5 Level of Quality



The quality level of Radiographic sensitivity required for radiographic inspection shall be at least equivalent to the values in Fig. 6.

16.6 Penetra meters

The image quality indicator (abbreviation: IQI) shall be used for the qualification of the welding procedure and during normal line production. Radiographic sensitivity shall be measured with the wire image quality indicator (Penetrameters). The Penetrameters shall be selected according to DIN54109 or ISO1027. For radiographs made with the source on the outside, a penetrometer shall be placed on each side of the film with the smaller wire of the penetrometer turned towards the end of the film with the smaller wire of the penetrometer turned towards the end of the film it self. When a completed weld is radiographed in a single exposure using a source inside the piping, four penetrameters approximately equally spaced around the circumference shall be used. During the procedure qualification, IQI shall be placed both on the source side and on the film side. The sensitivity obtained with IQI on the source side shall not be less than the values shown in Fig. 6 of this specification.

The sensitivity limit may be considered to have been reached when the outline of the IQI, its identification number and the wire of the required diameter show up clearly on the radiograph.

The COMPANY may authorize use of types of IQI other than those planned, provided that they conform with recognized standards and only if the CONTRACTOR is able to demonstrate that the minimum sensitivity level required is obtained. For this demonstration, a test shall be carried out comparing the IQI specified and the CONTRACTOR’S to show up the identification number and other details of the proposed IQI, which must be visible in the test radiograph.

	Laying, Installation, Testing and Commissioning of 8” dia. Steel gas pipeline connectivity in PATAN GA	
TENDER DOCUMENT NO REPL/SGL/STPL/009/22		Date: -06/12/2022

16.7 Film Identification Markers

All films shall be clearly identified by lead numbers, letters, and / or markers, The image of the markers shall appear on the films, without interfering with the interpretation. These markers positions shall also be marked on the part to be radiographed and shall be maintained during radiography.

16.8 Protection and care of film

16.8.1 All unexposed films shall be protected and stored property as per the requirements of API 1104 standard and ASTM E. 94.

16.8.2 The exposed and unexposed film shall be protected from heat, light, dust and moisture. Sufficient shielding shall be supplied to prevent exposure of film to damaging radiation prior to and following the use of the film for radiographic exposure.

16.9 Re-radiography

16.9.1 The weld joints shall be re-radiographed in case of unsatisfactory quality of the radiographs, at the expense of the CONTRACTOR.

16.9.2 All the repaired weld joints shall be re-radiographed at no extra cost to the COMPANY in the same manner as that followed for the original welds. In addition, the repaired weld areas shall be identified with the original identification number plus the letter R to indicate the repair.

16.9.3 When evaluation repair film, radiographers shall compare each section (exposure) of the weld with the original film to assure repair was correctly marked and original defect removed.



16.9.4 The COMPANY will review prior to any repair of welds, all the radiographs of welds which contain, according to the CONTRACTOR’s interpretation, unacceptable defects, The final disposition of all unacceptable welds shall be decided by the COMPANY.

16.10 Qualification of Radiographers

16.10.1 Pipeline radiographers shall be qualified in accordance with the requirement of API 1104 and to the full satisfaction of COMPANY.

16.10.2 Certificate of all the radiographers, qualified as per ASNT-TC-1A Level-2 above, shall be furnished by the CONTRACTOR to the COMPANY before a radiographer will be permitted to perform production radiography. The certificate record shall include.

- I Background and Experience Record
- .II Training Course Record.

	Laying, Installation, Testing and Commissioning of 8" dia. Steel gas pipeline connectivity in PATAN GA	
TENDER DOCUMENT NO REPL/SGL/STPL/009/22		Date: -06/12/2022

III Technical Examination Record.

IV Doctor's report on radiographer's 0-1 acuity eye test. V

Date of qualification

16.10.3 The radiographers shall be required to qualify with each radiographic procedure they use, prior to performing the work assigned to him in accordance with the specification.

16.11 Preservation of Radiographs.

16.11.1 The radiographs shall be processed to allow storage of films without any discoloration for at least three years. All the radiographs shall be presented in suitable folders for preservation along with necessary documentation.

16.11.2 All radiographs shall become property of the COMPANY.

16.12 Equipment and Accessories.

16.12.1 CONTRACTOR shall make necessary arrangement at his own expense, for providing the radiographic equipment, radiographic film and all the accessories for carrying out the radiographic examination for satisfactory and timely completion of the job.

16.12.2 For carrying out the mainline radiographic examination the CONTRACTOR shall be equipped with suitable mobile / stationary type dark rooms.

16.13 Radiation Protection



16.13.1 CONTRACTOR shall be responsible for the protection and personnel monitoring of personnel with or near radiation sources.

16.13.2 The protection and monitoring shall comply with local regulations.

16.13.3 In view of visual hazards in the handling of Radioactive source of material, CONTRACTOR shall be solely responsible for complying with all rules and regulation set forth by Atomic Energy Commission or any other Government agency of India in this regard and COMPANY shall not be responsible and shall be kept indemnified by the CONTRACTOR for default (s) responsible and shall be kept indemnified by the CONTRACTOR for default (s) whatever nature by the CONTRACTOR, Safety equipment as considered adequate by the COMPANY for all necessary personnel shall be made available for use and maintained for immediate and proper used by the CONTRACTOR.

16.14 Display of Safety Instructions

16.14.1 The safety provisions shall be brought to the notice of all concerned by display on a

	Laying, Installation, Testing and Commissioning of 8” dia. Steel gas pipeline connectivity in PATAN GA	
TENDER DOCUMENT NO REPL/SGL/STPL/009/22		Date: -06/12/2022

notice board at a prominent place at the work spot. The person responsible for the “safety” shall be named by the CONTRACTOR.

16.15 Enforcement of Safety Regulations

16.15.1 To ensure effective enforcement of the rules and regulations relating to safety precautions, the arrangement made by CONTRACTOR shall be open to inspection by COMPANY or its representatives.

16.16 First Aid and Industrial Injuries.

16.16.1 CONTRACTOR shall maintain first aid facilities for its employees and sub-contractors.

16.16.2 CONTRACTOR shall make outside arrangements for ambulance service and for treatment of industrial injuries. Names of those providing these services shall be furnished to COMPANY prior to start of work and their telephone no. shall be posted prominently in CONTRACTOR’S field office.

16.16.3 All critical industrial injuries shall be reported promptly to the COMPANY and a copy of CONTRACTOR’S report covering each personal injury requiring the attention of physician shall be furnished to the COMPANY.

16.17 No. Exemption

16.17.1 Notwithstanding the above there is nothing in these to exempt the CONTRACTOR from the operation of any other act or rules in force.



**Laying, Installation, Testing and
Commissioning of 8” dia. Steel gas
pipeline connectivity in PATAN GA**



TENDER DOCUMENT NO
REPL/SGL/STPL/009/22

Date: -06/12/2022

ANNEXURE-I

Sheet 1 of 3

ELECTRODE QUALIFICATION TEST RECORD

A. Tested at (Site name)

Date :

Manufacturer’s Name :

Brand Name :

Batch Number & Size Tested :

Classification & Code :

Intended for Welding in Positions:

In combination with (if any) :

Code of Reference :

(used for testing)

Special requirements

B. All weld Tensile Test :

Base Material used :

Pre-heat temp :

Postweld Heat Treatment Details:

Visual Examination :

Radiographic Examination Results :

Tensile Test Results

Sl. No.	Identification No.	U.T.S.	Yield Point Elongation
----------------	---------------------------	---------------	-------------------------------

1.

2.



Laying, Installation, Testing and Commissioning of 8” dia. Steel gas pipeline connectivity in PATAN GA



TENDER DOCUMENT NO
REPL/SGL/STPL/009/22

Date: -06/12/2022

ANNEXURE-I

Sheet 2 of 3

C. Impact Test Results :
 Test Temperature : Notch in:
 Type of Specimens : Size of Specimens:
 (Charpy)

Sl. No.	Specimen No.	Impact Value	Average
1.			
2.			
3.			
4.			
5.			
6.			

D. Chemical Analysis Result

Electrode Size used

:

Batch No.

:

%C	%S	%P	%SI	%Mn	%Cr	%Ni	%Mo	Other
----	----	----	-----	-----	-----	-----	-----	-------

E Fillet Weld Test Results :

Welding Positions :

Base Materials :

Size of Electrode used :

Visual Inspection Results : 1)

2)

Marco Test results :



Laying, Installation, Testing and Commissioning of 8” dia. Steel gas pipeline connectivity in PATAN GA



TENDER DOCUMENT NO
REPL/SGL/STPL/009/22

Date: -06/12/2022

ANNEXURE-I
Sheet 3 of 3

Fracture Test Results:

Remarks :

F. Other Test Results:

1. Transverse Tensile Test :
- In combination with :
- Base Material Used :
- Position of Welding :
- Preheat Temperature :
- Post Weld Heat Treatment:
- Radiography :

Identification No.	U.T.S.	Fracture in	Remarks
--------------------	--------	-------------	---------

2. Guided Bend Test

Position	ID No.	Root, Face or Side Bend	Remarks
	1.		
	2.		
	3.		
	4.		
	5.		

Any other Tests :

Conclusion :



Laying, Installation, Testing and Commissioning of 8” dia. Steel gas pipeline connectivity in PATAN GA



TENDER DOCUMENT NO
REPL/SGL/STPL/009/22

Date: -06/12/2022

ANNEXURE-II

Sheet 1 of 2

STRESS RELIFE HEAT TREATMENT PROCEDURE SPECIFICATION

Name of the Heat – Treater :

Name of the Project : Specification Reference No.

1. General Details :

Name of the Equipment :

Name of the Assembly/Part:

Assembly / Part Drawing No.:

Material :

2. Furnace Details :

Type of Heating : Gas / Oil / Elec. Res./Induction

Type of Heating : (Tick mark)

Capacity (Size) :

Maximum Temp. (C) :

Method of Temp :



Measurement :

Atmosphere Control :

3. Heat Treatment Cycle Details:

Changing Temp. C :

Rate of Heating, C / Hr. :

	Laying, Installation, Testing and Commissioning of 8” dia. Steel gas pipeline connectivity in PATAN GA	
TENDER DOCUMENT NO REPL/SGL/STPL/009/22		Date: -06/12/2022

ANNEXURE-II

Sheet 2 of 2

Soaking Temp. C

Soaking time, Hrs. Rate

of Cooling, C / Hr.Mode

of Cooling

4. Other Details, if any.

Notes:

The following documents shall be furnished along with the specifications:

- i. Material Test Certificates
- ii. Assembly / Part Drawing.



**Laying, Installation, Testing and
Commissioning of 8” dia. Steel gas
pipeline connectivity in PATAN GA**



TENDER DOCUMENT NO
REPL/SGL/STPL/009/22

Date: -06/12/2022

ANNEXURE-III

Sheet 1 of 3

WELDING PROCEDURE QUALIFICATION TEST RECORD

Example of record form for welding procedure approval test:

Project / Contract		Contractor	
Pipe and Coating Material			
Process			
Outside Diameter/Pipe			
Thickness			
Joint Design (Sketch Attached)			
Make and type of filler	Diameter	Current	Volts
Metal			
Root Second			
Run Other			
Runs			
Other Electrical	a c/d. c	Electrode +ve	
Characteristics		/ - ve	
Shielding Gas	:		
Type of mixture	:		
Flow	:		
Shielding Flux	:		
Position	:		
Direction of Welding	:		
Root	:	Vertical up / Vertical down	
Second Run	:	Vertical up / Vertical down	
Other Runs	:	Vertical up / Vertical down	
Number of Welders	:		
Root	:		
Second Run	:		
Other Runs	:		



Laying, Installation, Testing and Commissioning of 8” dia. Steel gas pipeline connectivity in PATAN GA



TENDER DOCUMENT NO
REPL/SGL/STPL/009/22

Date: -06/12/2022

Time lapse between commencement of Root and commencement of second run

ANNEXURE-III
Sheet 2 of 3

Time lapse between commencement of Second run and commencement of other run

Minimum number of runs before joint Allowed to cool

Maximum time between commencement And completion or weld

Type of line-up clamp

Removal of clamp after run :

Lowering off after run :
Cleaning

Preheating
Minimum temperature °C Ambient Temperature °C
Type of heater to be used

Interpass temperature

Minimum °C Maximum °C

Post weld heat treatment

Speed of travel Test

Results

State acceptable non-acceptable
(with reasons) or give numerical results Non –

destructive test :

Visual
Radiograph



Laying, Installation, Testing and Commissioning of 8” dia. Steel gas pipeline connectivity in PATAN GA



TENDER DOCUMENT NO
REPL/SGL/STPL/009/22

Date: -06/12/2022

ANNEXURE-III

Sheet 3 of 3
4

Destructive Tests	1	2	3
Transverse tensile			
Tensile strength (with units)			

Fracture location Test
temperature Macro –
examination Fillet
weldfracture

Hardness Survey :-

Type	Load	Location of hardness measurement (Sketch)
------	------	---

Hardness rang :

Parent metal :

Heat Affected Zone :

Weld :

Charpy V-notch impact tests

Specimen location and size

Notch location

Test temperature

Results (with units)

Additional test and tests and result e.g. chemical analysis, micro – examination, CTODtests, bend tests etc.

The statements in this record are correct. The test joints were prepared, welded and tested in accordance with the requirements of this specification.

Inspector Date

:



**Laying, Installation, Testing and
Commissioning of 8” dia. Steel gas
pipeline connectivity in PATAN GA**



TENDER DOCUMENT NO
REPL/SGL/STPL/009/22

Date: -06/12/2022

ANNEXURE-IV

Sheet 1 of 1

Example of record form for welder approval test:

Welder test certificate	Test No.	
Project / Contract	Date	
Contractor	Inspector	
Welder's name		
Address		
Pipe Material		
Pipe Thickness		
Pipe Outside Diameter		
Welding Process	Root	Fill and Cap
Electrode / Wire		
Root	Current	Voltage
Second run	Current	Voltage
Full and cap	Current	Voltage
Direction of travel	Root : Vertical Up / Vertical Down	Fill and cap: Vertical up Vertical down
Reason for failure	Visual	
Non-destructive testing		
Butt joint		
Fillet weld		
Number of attempts		
Comments		



Laying, Installation, Testing and Commissioning of 8” dia. Steel gas pipeline connectivity in PATAN GA



TENDER DOCUMENT NO
REPL/SGL/STPL/009/22

Date: -06/12/2022

WELDERS IDENTIFICATION CARD

ANNEXURE-V

Sheet 1 of 1

Name :
Identification :
Date of Testing :
Valid Until :
Welding Position :
Material :
Diameter :
Wall Thickness :
Type of Welding :
Consumables :

Approved by :

Employer's Signature with Seal



Laying, Installation, Testing and Commissioning of 8” dia. Steel gas pipeline connectivity in PATAN GA



TENDER DOCUMENT NO
REPL/SGL/STPL/009/22

Date: -06/12/2022

ANNEXURE-VI

Sheet 1 of 1

RADIOGRAPHIC PROCEDURE FOR PIPE WELDING

1. Location
2. Date of Testing
3. Name of Supervised Contractor
4. Material
5. Dia & Thickness
6. Type of Weld joint
7. Radiation Source
8. Type of equipment (External/ Internal)
9. Intensifying Screens and Material
10. Filter Type and placement mask, Diaphragm Lead Screen etc., adjacent or Radiation Source or Specimen
11. Geometric Relationship (Source local spot size, max and min source strength, object to film distance, radiation angle with respect to weld and film.
12. Limit of film coverage
13. Film type and make
14. Exposure Time
15. Processing (time temperature for development, stop bath or rinse, fixation, washing, drying etc.)
16. Density
17. Sensitivity
18. Type of penetrometer.

Approval of the COMPANY

Signature of CONTRACTOR with seal



**Laying, Installation, Testing and
Commissioning of 8" dia. Steel gas
pipeline connectivity in PATAN GA**



TENDER DOCUMENT NO
REPL/SGL/STPL/009/22

Date: -06/12/2022



Sabarmati Gas Ltd.
(A Joint Venture of GSPC and BPCL)

SABARMATI GAS LIMITED

**Laying, Installation, Testing and Commissioning of 8" dia. Steel
gas pipeline connectivity in PATAN GA**

RESONANCE ENERGY PVT. LTD.

**Specification for Hydrostatic Testing
Tender No. REPL/SGL/STPL/009/22**



**Laying, Installation, Testing and
Commissioning of 8” dia. Steel gas
pipeline connectivity in PATAN GA**



TENDER DOCUMENT NO
REPL/SGL/STPL/009/22

Date: -06/12/2022

CONTENTS

- 1.0 SCOPE
- 2.0 REFERENCE CODES, STANDARDS AND SPECIFICATIONS
- 3.0 GENERAL
- 4.0 HYDROSTATIC TEST PROCEDURE MANUAL
- 5.0 TEST PRESSURE
- 6.0 EQUIPMENT AND INSTRUMENTATION
- 7.0 PROCEDURES
- 8.0 ACCEPTANCE
- 9.0 TERMINATION
- 10.0 TEST REPORT
- 11.0 MEASUREMENTS
- 12.0 CALCULATION
- 13.0 PRECAUTIONS DURING THE TEST
- 14.0 PRESERVATION OF PIPELINE



Laying, Installation, Testing and Commissioning of 8” dia. Steel gas pipeline connectivity in PATAN GA



TENDER DOCUMENT NO
REPL/SGL/STPL/009/22

Date: -06/12/2022

1. **SCOPE**

1.1 This specification covers the minimum requirements of supply, works and operation to be performed by CONTRACTOR for hydrostatic testing of cross-country steel pipelines transporting hydrocarbons in liquid or gaseous phase under high pressure. This specification does not cover the requirements of drying/pre-commissioning of the tested pipelines. This specification shall be read in conjunction with the conditions of all specifications and documents included in the CONTRACT between COMPANY and CONTRACTOR.

2.0 **REFERENCE CODES, STANDARDS AND SPECIFICATIONS**

2.1 Reference has been made in this specification to the latest edition/revision of the following codes, standards and specifications.

- a) ANISI B 31.8 Gas Transmission and Distribution Pipingsystems
- b) ANSI B 31.4 Liquid Petroleum Transportation Pipingsystem
- c) API RP 1110 Pressure Testing of Liquid Petroleum Pipelines
- d) ASME Sec. VIII Div.1 Boiler & Pressure Vessel Code.
- e) OISD 141 Design & construction requirements for cross-country hydrocarbon pipeline.

2.2 In case of conflict between the requirements of this specification and that of the above referred coded, standards, and specifications, the requirements of this specifications shall govern.

2.3 For the purpose of this specification the following definitions shall hold.



- the words “shall” and „Must” are mandatory.
- The words „Should”, „May”, and “Will” are non-mandatory, advisory or recommended.

3.0 **GENERAL**

3.1 Hydrostatic test shall be performed on the entire length of the pipeline. Hydrostatic test shall be performed in accordance with approved Hydrostatic Test diagrams for each test section. The maximum length of each test section shall not exceed 25 kms.

3.2 For pipeline section which in COMPANY”s opinion, once installed would require an inordinate amount of effort for repair in case of a leak, a provisional pre-tested shall be conducted, However, after installation, such pretested sections shall be tested again along with the entire pipeline.

3.3 Hydrostatic test shall commence only after mechanical and civil works completion, i.e. all welds have been accepted and the pipeline has been laid and backfilled according to the specifications. Hydrostatic test shall include those sections which have been previously tested, viz Rail/ road crossing, major water crossings including test on banks and in place after installation, and scraper traps at the terminals CONTRACTOR shall

	Laying, Installation, Testing and Commissioning of 8” dia. Steel gas pipeline connectivity in PATAN GA	
TENDER DOCUMENT NO REPL/SGL/STPL/009/22		Date: -06/12/2022

perform all works required for hydrostatic testing after obtaining prior written approval from the COMPANY.

- 3.4** The pipeline shall be tested in accordance with the requirements of the latest edition of ANSI B 31.8 or ANSI B.31.4, OISD 141 as applicable, and requirements laid down in this specification.

4 **HYDROSTATIC TEST PROCEDURE MANUAL**

CONTRACTOR shall prepare for COMPANY’S approval a hydrostatic test procedure manual. The procedure shall strictly comply with the requirements of this specification and shall be submitted to COMPANY for approval well in advance. The procedure manual shall include all temporary materials & equipment, but not be limited to the following items.

- a) For the systems to be tested a diagram indicating all fittings, vents, valves, temporary connections, relevant elevations and ratings. The diagram shall also indicate injection locations and intake and discharge lines.
- b) Estimated amount of test water, water sources, including required concentration of corrosion inhibitors and additives, procedure for inhibitor injection and control of concentration.
- c) Filling and flushing procedures, including a complete description of all proposed equipment and instruments (including spares) their location and set-up.
- d) The type and sequence of pigs and the pig tracking systems for cleaning and removal of air pockets. Pig inspection procedures, including procedure to be followed in case the calliper pig indicates damage.
- e) Procedures for leveling and stabilization after filling and for pressurization and to allow for temperature stabilization.
- f) Pressure testing procedure including a complete description of all proposed equipment and instruments (including spares) their location and set-up and proposed system for observation and recording of data during the pressure test.
- g) Procedure for detection and location of leaks.
- h) Procedure for dewatering the pipeline section(s) after testing, including a complete description of all proposed equipment and instruments, (including spares) their location and set-up, the type and sequence of pigs and the pig tracking system along with the pig specifications.
- i) Forms for recording the test data.



Laying, Installation, Testing and Commissioning of 8" dia. Steel gas pipeline connectivity in PATAN GA



TENDER DOCUMENT NO
REPL/SGL/STPL/009/22

Date: -06/12/2022

5 TEST DURATION AND PRESSURE

- 5.1 The duration of hydrostatic test shall be a minimum of 24 hours after stabilization and the test pressure shall be as indicated in the approved hydrostatic test diagram.
- 5.2 Unless specified otherwise in the CONTRACT, the maximum base pressure shall not be higher than the one resulting in a hoop stress corresponding to 90% of SMYS of pipe material based on the minimum wall thickness in the test section and minimum test pressure shall not be lower than the one resulting in a hoop stress corresponding to 85% of SMYS of pipe material based on the minimum wall thickness in the test section.
- 5.3 All buried steel pipelines and mains shall be pressure tested after installation using water as a test medium. Minimum test pressure shall be equal to 1.4 times *Maximum Allowable Operating Pressure*.

6 EQUIPMENT AND INSTRUMENTATION

The CONTRACTOR Shall furnish all necessary equipment for performing the work as stated in cleaning, flushing, filling, leveling, stabilizing, testing and dewatering procedures. This shall include the following :

- a) Pigs for filling, cleaning and gauging including.
- Cleaning pigs with spring loaded steel wire brushes except for internal coated pipes. In this case pigs to be provided with nylon / polyurethane brushes.
 - Four cup batching pigs.
 - Caliper pigs with gauge plate diameter equal to 95% of the heavy wall pipe in the pipe sections. Gauging pig fitted with gauge plate.

The CONTRACTOR shall provide sufficient number of pigs including spares.

- b) Fill pumps: The CONTRACTOR shall determine the type and number of fill pumps in order to guarantee the following.
Differential head 20% greater than the maximum required. Flow rate : 400m³ min. 200m³ max.
If single pump is used, a standby unit must be available.
- c) Variable speed positive displacement pumps equipped with a stroke counter to pressurize the line with a known stroke and capable of exceeding the maximum test pressure by at least 20 bar.
- d) Two positive displacement meters to measure the volume of water used for filling the line. These meters shall be provided with a calibration certificate



Laying, Installation, Testing and Commissioning of 8" dia. Steel gas pipeline connectivity in PATAN GA



TENDER DOCUMENT NO
REPL/SGL/STPL/009/22



Date: -06/12/2022

not older than one month.

- e) Portable tanks of sufficient size to provide a continuous supply of water to the pump during pressurizing.
- f) Bourdon pressure gauges of suitable pressure range and accuracy.
- g) Dead weight testers with an accuracy of 0.01 bar measuring in increments of 0.05 bar provided with a calibration certificate not older than one month.
- h) Two 48 hours recording pressure gauges tested with charts and ink gauges tested with dead weight tester prior to use. These shall be installed at the test heads.
- i) Pressure recording charts.
- j) Two temperature recorders for fill water.
- k) Thermocouples for measuring the pipe wall temperature.
- l) Two laboratory thermometers 0°C to 60°C range, accuracy + 0.1 degree to be used in their no wells.
- m) Means to measure the volume of water necessary to drop the line pressure by 0.5 bar (container on scales or graduated cylinder).
- n) Injection facilities to inject additives into the test medium in the required proportions.
- o) Communication equipment suitable for a continuous connection between the beginning and the end of the test section and with the inspection team along the line in accordance with the requirements of local authorities.
- p) The temporary scraper traps shall be installed according to the testing sections fixed in the test procedure manual, Proper piping and valving arrangements shall be available to allow launching and receiving of each pig independently.

The test heads shall be sized in conformity with ASME specification Section VIII, Division 2 with particular reference to Appendices 4 and 5.

- q) Thermocouples for assuring the temperature of the pipe wall shall be installed on the pipeline to be tested:
 - 1 thermocouple at about 500 m distance from the pumping head.
 - 1 thermocouple every 2500 m of the pipe the spacing may be increased to maximum 5000m depending on the terrain and nature

	Laying, Installation, Testing and Commissioning of 8” dia. Steel gas pipeline connectivity in PATAN GA	
TENDER DOCUMENT NO REPL/SGL/STPL/009/22		Date: -06/12/2022

of sub-soil along the alignment of section.

- 1 thermocouple at about 500 m distance from the terminalhead.

7 PROCEDURES

7.1 Equipment and/or parts which need not or must not be subjected to the test pressure must be disconnected or separated from the pipeline to be tested.

7.2 If the difference of minimum and maximum atmosphere temperature should cause thermal instability on the pipe section directly exposed to atmospheric condition, the scraper traps and above ground pipeline shall be properly protected.



The pipeline test shall exclude long segments of line exposed to atmospheric conditions, viz Aerial lengths on piers, suspension bridges, etc, which shall be tested separately.

7.3 The test medium shall be soft non-aggressive water furnished by the CONTRACTOR. The water to be used shall be filtered, shall not be contaminated, and free from sand or silt. CONTRACTOR shall submit laboratory test reports of water used for testing. The possible use of sea water shall be subject to its degree of cleanliness, the possibility of obtaining a pre-determined salinity neutralization and the use of corrosion inhibitors, this at the sole discretion of COMPANY, CONTRACTOR shall provide COMPANY approved corrosion inhibitors, oxygen scavengers and bactericides to be added to the test water. The CONTRACTOR shall furnish and install all temporary piping which may be necessary to connect from source of water to its pumps and manifolds/ tankage.

7.4 Before filling operation the CONTRACTOR shall clean the pipeline by air driven pigs provided with spring loaded bushes and chisets to remove all mill scale rust/ sand from the inside of pipe section. For this purpose, temporary header for air cleaning shall be attached to the pipeline. The number of pig runs is depending upon the cleaning results and shall be determined by the COMPANY at site.

7.5 After cleaning the pipeline by using air and acceptance by company, gauging shall be carried out by using gauging pig. The gauge plate diameter shall be equal to 95% of inside diameter of the heaviest wall pipe in the test section. While computing the ID of heaviest wall pipe, pipe manufacturing tolerance shall not be considered. A 10 mm thick minimum plate shall be used for making gauge plate.

After receipt of gauging pig at the other end, the gauge plate shall be inspected in the presence of Company representative. A deformed, bent or severally nicked plate or damaged pig shall be evidence of gauging pig run failure and the same is not acceptable to company. In such cases the Contractor shall repair and rectify the line and repeat the gauging pig run

	Laying, Installation, Testing and Commissioning of 8” dia. Steel gas pipeline connectivity in PATAN GA	
TENDER DOCUMENT NO REPL/SGL/STPL/009/22		Date: -06/12/2022

to the satisfaction and approval of the Company Representative. Any obstruction and/or faults such as dents, buckles, flat spots, etc. analyzed and noted during gauging pig run shall be located and any necessary repair work shall be performed to rectify the same to the satisfaction of the Company. A written approval shall be obtained from Company regarding successful completion of gauging pig run.

After acceptance of gauging operation, air header shall be cut and removed protested test headers loaded with three numbers of four cup batching pigs shall be welded to test Section. Un-inhibited water equal to 10% of the volume of test section shall be introduced in front of the first pig. The first pig shall be launched by introducing about 1.5 km un-inhibited water. Then the second pig shall be launched by pumping the inhibited water till the second pig is received at the other end. The thermal stabilization and pressurization can now the started”.

7.6 Thermal Stabilization

After a check has been made to confirm if the pressure has attained at least 1 bar(g) on the highest section, thermal stabilization can be started.

Thermal equilibrium between the pipeline and environment shall be checked through the thermocouples installed on the pipeline.

Temperature readings shall be made at 4 hour-intervals. Thermal stabilization shall be considered to have been achieved when a difference not higher than 1°C is attained between the average values of the last two readings. Thermal stabilization completion shall be approved by COMPANY.



7.7 Pressurization

Pressurization shall be performed in the presence of COMPANY at moderate and constant rate not exceeding 2bars/min. One pressure recording gauge shall be installed in parallel with the dead weight tester. Volume required to reach the test pressure shall be recorded periodically throughout the pressurization as follows:

- each 5 bar increments up to 80% of test pressure as recorded by the dead weight tester,
- each 2 bar increment between 80% to 90% of test pressure as recorded by the dead weight tester,
- each 0.2 bar increment between 90% of test pressure to full test pressure as recorded by the dead weight tester.

The pressurizing shall be cycled according to the following sequence.

- a) Pressurize to 50% of test pressure, hold pressure for 1 hour.
- b) Drop pressure to static head of test section at test head.
- c) Pressurize to 75% of test pressure, hold pressure for 1 hour.
- d) Drop pressure to static head of test section at the test head.

	Laying, Installation, Testing and Commissioning of 8” dia. Steel gas pipeline connectivity in PATAN GA	
TENDER DOCUMENT NO REPL/SGL/STPL/009/22		Date: -06/12/2022

e) Pressurize to test pressure.

During the pressurization to each test pressure, two tests shall be carried out for the calculation of air volume in the pipeline under test.

In case, during the hold pressure periods indicated above, a decrease in pressure is observed, the operations shall not be repeated more than twice, after which the line shall not be considered capable of test, until the CONTRACTOR has isolated and eliminated the cause for the lack of water tightness.

7.8 Air Volume Calculation

In order to check the presence of air in the pipeline, two separate consecutive pressures lowering of 0.5 bar shall be carried out.

For calculation of air in the pipeline the second pressure lowering shall be used, and the relevant drained water shall be accurately measured (V1). This amount measured shall be compared to the theoretical amount (Vp) corresponding to the pressure lowering that has been carried out, by using the procedure outlined in clause 12.1 of this specification.

If no air is present in the length under test

$$\frac{V1}{Vp} \leq 1.06$$

If the air found in the pipeline is within the above established tolerance, then the pressurizing can continue. If the ration V1. / Vp exceeds 1.02 the hydrostatic testing cannot go on and additional pig passages shall be performed to remove the air pockets.

The test shall be repeated as per the above procedure until above estimated tolerances are satisfied. The pressurizing can then continue, to reach the value of test pressure.

7.9 Testing

After the section has been pressurized and the air volume test has given acceptable results the test pressure shall be held for a minimum of 24 hours after stabilization. After temperature and pressure has stabilized, the injection pump shall be disconnected and all connections at the test heads shall be checked for leakage. The pressure recorders shall then be started with the charts in a real time orientation for continuous recording throughout the test.

During the testing period the following measurements shall be recorded:

- Every one hour pressure measurements form dead weight testers.



Laying, Installation, Testing and Commissioning of 8” dia. Steel gas pipeline connectivity in PATAN GA



TENDER DOCUMENT NO
REPL/SGL/STPL/009/22

Date: -06/12/2022



- Every two hours the ambient temperature and the pipe temperature at the thermocouples

All data shall be recorded on appropriate forms attached to the hydrostatic test procedure manual. Care shall be taken that the maximum test pressures are not exceeded.

Bleed-off water shall be accurately measured and recorded.

8 **ACCEPTANCE**

- 8.1 The hydrostatic test shall be considered as passed if pressure has kept a constant value throughout the test duration, except for change due to temperature effects such change shall be evaluated as described under clause 12.2 of this specification. The pressure change value as a function of temperature change shall be algebraically added to the pressure value as read on the meters. The pressure value thus adjusted shall be compared with the initial value and **the test shall be considered as acceptable if the difference is less than or equal to 0.19 bar.** In case of doubt the testing, period shall be extended by 24 hours.
- 8.2 If test section fails to maintain the specified test pressure after isolation, CONTRACTOR shall determine by search the location of leakage or failure. All leaks and failures within the pipe wall or weld seam shall be repaired by replacement of entire joint or joints in which leakage or failure occurs. In circumferential welds the method of repair shall be determined by the COMPANY. CONTRACTOR shall comply with instructions of the COMPANY whether to replace a section of the line pipe that includes the line leak or whether to repair the circumferential weld. This repair should however meet the requirements of „ Specification for Welding Pipelines and Related Facilities“. Where failure occur in pipeline field bends, bends shall be replaced with same degree of bends. After completion of repairs, the hydrostatic test shall be repeated in full, as per this specification.
- 8.3 The cost of repairs or replacements, followed by refilling and depressurizing the line, due to poor workmanship, shall be borne by the CONTRACTOR. In the event of leaks or failures resulting from faulty COMPANY furnished materials, CONTRACTOR shall be reimbursed for furnishing all labour, equipment, materials, except those materials furnished by the COMPANY, and transportation necessary to repair and re-pressurize the section of the pipeline to the pressure at the time of recognition of leak or line failure. CONTRACTOR shall be entitled for compensation as per the provisions of the CONTRACT. All work of reinstalling line pipe, to replace pipe failures shall be done in accordance with the relevant specification included in the CONTRACT.
- 8.4 CONTRACTOR shall haul and stockpile all damaged and defective pipes to storage locations designated by the COMPANY All cracks and splice resulting from failures shall be coated with an application of grease to preserve the characteristics of failures from corrosion. Joint of failed pipes shall be marked with paint with a tag indicating failure details, date and location of failure and pressure at which failure occurred.

	Laying, Installation, Testing and Commissioning of 8” dia. Steel gas pipeline connectivity in PATAN GA	
TENDER DOCUMENT NO REPL/SGL/STPL/009/22		Date: -06/12/2022

9 TERMINATION

After the positive results of testing and collection of all data the test shall be terminated upon written approval given by the COMPANY.

- 9.1 CONTRACTOR shall dewater the tested line as per the following requirement after test acceptance.

The dewatering shall be carried out by using four cup pigs and foam pigs driven by compressed air. The detailed dewatering procedure shall be developed by the CONTRACTOR in such a way as to provide adequate control of pigs during dewatering. Pigs and equipment required for dewatering the line shall be furnished by CONTRACTOR and shall be approved in advance by the COMPANY. Four cup pigs shall first be passed through the line to displace the water. Foam pigs shall then be passed in order to complete the line dewatering. CONTRACTOR shall use a number of foam pigs, each in different colors / numbered for this purpose. The line shall be considered dewatered when a negligible amount of water is flushed out by the last foam pig and approval is given by the COMPANY.

- 9.2 During dewatering, care shall be taken to properly dispose the discharging water in order to avoid pollution, damages to fields under cultivation and/or existing structures and interference with the traffic. Before start of dewatering and disposal of hydro test water, a procedure for treatment of inhibited water to prevent pollution shall be submitted by contractor to owner/consultant for review and approval.

- 9.3 Upon completion of the testing and dewatering operation, any provisional traps for pigs and all other temporary installation relating to the test shall be removed. Subsequently the individual sections of the line already tested shall be joined in accordance with the requirements of relevant specifications issued for the purpose.

10 TEST REPORT

A complete report signed by CONTRACTOR and the COMPANY shall be submitted upon completion of the hydrostatic test for each test section.

This report shall contain as a minimum

- the cleaning, flushing, filling and testing procedures used,
- schematic layout of cleaning, filling and testing facilities,
- instrument calibration certificates;
- a profile of the pipeline that shows the test sites, all instrument and injection connections;
- pipe filling logs and records,
- additive specification, required concentration and additive injection records;
- pig specifications;
- pig inspection records including photographs of the damages;
- records of gauging pig survey and photographs;



Laying, Installation, Testing and Commissioning of 8” dia. Steel gas pipeline connectivity in PATAN GA



TENDER DOCUMENT NO
REPL/SGL/STPL/009/22

Date: -06/12/2022

- pressurization and stabilization records;
- pressure and temperature recording charts with appropriate information inscribed thereon;
- temperature data along the pipeline;
- dead weight tester logs and recording;
- air volume calculations;
- pressure change due to temperature change calculations;
- environmental data;
- depressurization logs and records;
- dewatering procedure and schematic layout of relevant facilities;

Further the temperature measurement shall be taken;

- During the filling operation.
- During the thermal stabilization stage.
- During the hydrostatic test.

The thermocouple's sensitivity shall enable temperature readings with an accuracy of $\pm 0.2^{\circ}\text{C}$

- b) Water temperature shall also be measured on the pump delivery by means of a recording thermometer (temperature recorder) throughout the filling stage.



The recording thermometer shall have the following features;

Accuracy $\pm 1\%$ of the scale range

Scale $- 10^{\circ}$ to 40°C

Recording Continuous on tape or disk, diagram within 100mm Feed :
20mm/h for tape diagrams, 7.5%/h for disk diagrams.

- c) Ground temperature shall be taken by measuring pipe temperature at the thermocouple prior to starting the filling operation.
- d) Environmental temperature shall be recorded from the beginning of pressurization to the end of the test by means of a recording thermometer featuring the following characteristics;
- Accuracy $\pm 1\%$ of the scale range
- Scale $- 0^{\circ}$ to $\pm 60^{\circ}\text{C}$
- Recording Continuous on tape or disk, diagram width 100mm Feed
20mm/h for tape diagrams, 7.5%/h for disk diagrams.
- dewatering logs and records;
 - records and photograph of all leaks.

	Laying, Installation, Testing and Commissioning of 8” dia. Steel gas pipeline connectivity in PATAN GA	
TENDER DOCUMENT NO REPL/SGL/STPL/009/22		Date: -06/12/2022

11.0 **MEASUREMENTS**

11.1 **Water Amount Measurement**

The water volume added to the section to be tested shall be measured during the filling stage through a positive displacement meter (a turbine meter may also be used) In the calculation, as per clause 12.1 of this specification, use shall be made of the geometrical volume of the section in question.

11.2 **Pressure Measurement**

Pressure shall be measured with a dead weight tester with an accuracy of 0.01 bar that shall permit readings of at least 0.05 bar.

During the test the pressure shall be recorded by means of a pressure recorder featuring the following specifications:

Accuracy	:	+ 0.1% of the full-scale value
Recording	:	continuous on tape or disk, graph width 100 mm
Feed	:	20mm/h for tape diagrams, 7.5/h for disk diagrams
Recording	:	to be such as to record pressure between 50% and 90% of the diagram width.

The pressure recorder shall be checked by means of dead weight tester at the beginning, during and at the end of the hydrostatic test.

A pressure gauge tested with dead weight tester shall be connected in parallel to the dead weight tester at the test head.

11.3 **Temperature Measurements**

Water temperature shall be taken at every 2 hours through the thermocouple that have been installed on the pipe wall along the section under test on the pipe wall.

12 **CALCULATIONS**

12.1 The theoretical water amount that is necessary for filling the section to be tested shall be obtained from the geometrical volume of the section considering the pipe tolerances.

The theoretical water amount that is necessary for pressurizing the section shall be calculated by means of the following formula;

$$V_p = (0.884 r_i/t + A) \times 10^6 \times V_t \times P \times K^t$$

Where

V=	computed water amount required to raise by P the pressure in the section to be tested (m ³)
V _t =	geometrical volume of the section (m ³)
P=	Pressure rise (bar)
r _i =	nominal inner radius of the pipe (mm)
t=	



Laying, Installation, Testing and Commissioning of 8” dia. Steel gas pipeline connectivity in PATAN GA



TENDER DOCUMENT NO
REPL/SGL/STPL/009/22

Date: -06/12/2022

nominal pipe thickness (mm)

A= isothermal compressibility value for water at the pressurization temperature in the P range (bar-1) x 10⁶

(Refer water compressibility factor vs pressure and temperature chart) For temperature above 30°C the values may be extrapolated.

K= a dimensionless coefficient that is equal to a value of 1.02 for longitudinally welded pipe.

12.2 The pressure change due to a water temperature change shall be calculated by the following formula:

$$P = \frac{B}{0.884 r I / t + A}$$

Where,

P = pressure change resulting from a temperature change (bar)

T = algebraically difference between water temperature at the beginning of the test and water temperature as measured at the end of the test (C)

B = value of the difference between the thermal expansion water at the pressure and temperature as measured at the end of the test and that of steel (c-1) × 10

(Refer table – 1)

A = Isothermal compressibility value of water as estimated at the pressure and temperature values obtained at the end of test (bar-1) × 10⁶ (refer Figure 1)

R I = nominal inner radius of the pipe (mm)

For Hydrostats tester

Before foresting of the pipeline section the above mentioned sections shall be pre-tested for 6 hours duration to ensure.

No leakage :

During :

Pipeline shall be dried up to dew point of 8°C drying procedure shall be submitted by contractor to company's

Representative for approval.

t = nominal thickness of pipe (mm).

13.0 PRECAUTIONS DURING THE TEST

In addition to all that has been expressly described in the procedures for carrying out that tests, the following additional requirements shall be complied with:



Laying, Installation, Testing and Commissioning of 8” dia. Steel gas pipeline connectivity in PATAN GA



TENDER DOCUMENT NO
REPL/SGL/STPL/009/22

Date: -06/12/2022

- 13.1 Provision shall be made for the installation of no – admittance signs to unauthorized personnel from the roads to the R.O.W. Relevant Warning Signs shall be displayed at the test area.
- 13.2 Proper communication facilities shall also be arranged for during testing. The test area shall be properly cordons to prevent any accident.
- 13.3 A proper Emergency Response Plan shall be in place and emergency contact number of relevant agencies should be visible
- 13.4 Signs stating “PIPE UNDER TEST – KEEP OFF “with local language translation shall be placed where the pipeline is uncovered, and particularly where the provisional traps and stations are located. Such areas shall be suitably fenced in such a way as to prevent access of unauthorized personnel. No unauthorized personnel shall be closer than 40 m to the pipeline or equipment under test.
- 13.5 Provisional scraper traps shall be installed in compliance with methods and suitable locations so that their rupture cannot cause any injuries to the personnel or third parties.
- 13.6 The test station shall be placed in such a location as to prevent it from being affected by a catastrophic failure in the test head.
- 13.7 Once dewatering is over, the sectionalizing valves and other and other valve assemblies tested previously shall be installed at locations shown in the drawings and in accordance with the procedures contained in the relevant specifications. All thermocouple installed in the pipeline shall be removed and damaged corrosion coating shall be repaired using COMPANY approved materials and procedure.
- 14.0 **PRESERVATION OF PIPELINE**

When so stated in the CONTRACT, to preserve / conserve the pipeline for a specified duration CONTRACTOR shall completely fill the pipeline with water, with sufficient quantity of corrosion inhibitors depending upon quality of water and the period of conservation at a pressure to be agreed upon with the COMPANY at a later stage. CONTRACTOR shall obtain necessary approval from the COMPANY of the procedure and the type and quantity of the inhibitors used before commencement of the work.



Sabarmati Gas Ltd.

(A Joint Venture of GSPC and BPCL)

SABARMATI GAS LIMITED

**LAYING, INSTALLATION, TESTING AND COMMISSIONING OF 8”
DIA. STEEL GAS PIPELINE CONNECTIVITY IN PATAN GA**

RESONANCE ENERGY PVT. LTD.

**Specification for Major Water Crossings
Tender No. REPL/SGL/STPL/009/22**

0	25/11/2022	Issued for RFP	AS	PG	PC
Rev.	Date	Description	Prepared By	Checked By	Approved By



**Laying, Installation, Testing and
Commissioning of 8” dia. Steel gas
pipeline connectivity in PATAN GA**





TENDER DOCUMENT NO
REPL/SGL/STPL/009/22

Date: -06/12/2022

C O N T E N T S

0.0	DEFINITION
1.0	SCOPE
2.0	GENERAL
3.0	TRENCHING
4.0	CONTINUOUS CONCRETE COATING
5.0	HYDROSTATIC PRE-TESTING
6.0	INSTALLATION
7.0	BACKFILLING AND BANK PROTECTION
8.0	FINAL HYDROSTATIC TEST
9.0	POST-CONSTRUCTION SURVEY
10.0	FINAL CLEAN-UP
11.0	DOCUMENTATION
12.0	PERMISSIONS

	<p>Laying, Installation, Testing and Commissioning of 8” dia. Steel gas pipeline connectivity in PATAN GA</p>	
<p>TENDER DOCUMENT NO REPL/SGL/STPL/009/22</p>		<p>Date: -06/12/2022</p>

1. SCOPE

This specification covers the minimum requirements for the variation activities to be performance by CONTRACTOR for the construction of pipeline major water crossing by conventional trenching methods. Provisions of this specification are applicable only for “major water crossing” specifically named as such in the CONTRACT.

This specification shall be read in conjunction with the conditions of all the specifications and documents in the CONTRACT between COMPANY and CONTRACTOR.

CONTRACTOR shall, with due care and diligence, execute the work in compliance with all laws, by-laws, ordinance, regulations etc., and provide all services and labour, inclusive of supervision thereof, all materials excluding, the material indicated as “Company supplied materials” in the contract, equipment appliances or other things whatsoever nature required in or about the execution of the work, whether of temporary and permanent natures.

CONTRACTOR shall take full responsibility for the stability and safety of all operation and methods involved in the work.

CONTRACTOR shall be deemed to have inspected and examined the work area and its surroundings and to have satisfied himself so far as practicable as to the form and nature thereof, including subsurface condition, hydrological and climate conditions, the extent and the nature of the work and material necessary for the completion of the work, and the means of access to the work area.

CONTRACTOR shall be deemed to have obtained the entire necessary information subject as above mentioned as to risk, contingencies and all other circumstances, which may influence the work.



CONTRACTOR shall in connection with the work, provide and maintain at his own costs all lights, guards, fencing, watching etc., when and where necessary or required by the company or by any duly constituted authority for the protection of the work and properties or for the safety and convenience of the public or the other,

For the purpose of this specifications the following definitions shall hold:

- The words “Shall” and “Must” are mandatory
- The words “Should” and “May”, “Will” are non-mandatory, advisory or recommended.

2. GENERAL

All works of the pipeline major water crossings shall be performed in accordance with the approved construction drawings, procedures other applicable documents as per the CONTRACT , good pipeline practices and as directed by COMPANY.

	Laying, Installation, Testing and Commissioning of 8” dia. Steel gas pipeline connectivity in PATAN GA	
TENDER DOCUMENT NO REPL/SGL/STPL/009/22		Date: -06/12/2022

Before start of the field construction, CONTRACTOR, shall submit in triplicate to COMPANY, for approval for each major water crossing a complete report containing as below:

- i. The installation procedure / method along with QAP.
- ii. Proposal time schedule indication start and finish dates and detailed breakup of time period of all critical activities associated with the work.
- iii. Required work area along with layout and location.
- iv. Equipment to be used including number and application equipment.
- v. Manpower deployment during construction.
- vi. Proposed subcontractors and / or vendors along with their scope of work.



The description of the installation method includes the following.

- a) Study of riverbed including soil investigation and collection of hydrological data.
- b) Calculation for stability of pipeline during launching and final test.
- c) Buoyancy studies
- d) Preparation of fabrication yard and launching areas,
- e) Pipeline construction details (handing, stringing, welding, concrete coating etc.)
- f) Pre-test procedure including trial mix, design & tests for concrete coating.
- g) Procedure for corrosion coating of field joint
- h) Dredging, anchoring program, spoil-deposit and trench survey method including facilities for COMPANY
- i) Pulling or other installation method and related calculations.
- j) Pulling arrangement including launch way and anchoring and breaking device
- k) Trench correction before launching.
- l) Method of positioning and sinking of pipeline,
- m) Method of rectification of damages to the pipeline during launching.
- n) Method of backfilling bank protection and survey.
- o) Final test procedure after backfilling.
- p) Safety systems during launching rope tests.
- q) Communication.
- r) Abandonment and recovery procedures concurred.
- s) Necessary permission from concerned authorities for crossing

COMPANY shall inform CONTRACTOR within 21 days if any objection against the document and procedure described requires resubmission by CONTRACTOR.

Approval by COMPANY of the methods used by CONTRACTOR shall in no way relieve CONTRACTOR from the sole responsibility for safe and satisfactory installation of the crossing.

- 2.3 CONTRACTOR shall comply with all the conditions and requirements issued by authorities having jurisdiction in the area where the work is to be performed. CONTRACTOR shall at his own responsibility, obtain necessary permits from

	Laying, Installation, Testing and Commissioning of 8” dia. Steel gas pipeline connectivity in PATAN GA	
TENDER DOCUMENT NO REPL/SGL/STPL/009/22		Date: -06/12/2022

the authorities having jurisdiction, for performing his work.

If no public roads exist, CONTRACTOR shall arrange on his own for access to his work area at no extra cost to COMPANY.

2.4 Pre-construction Surveys

Prior to start of any work, CONTRACTOR shall carry out a survey of the major water crossings and acquaint himself with site conditions and to collect any data regarding the water velocity and the tidal variations in the flow pattern and shall verify the suitability of his equipment and the methods of construction.

3.0 **Trenching**

3.1 Dredging Excavating

3.1.1 CONTRACTOR shall dredge or excavate the trench for the water crossing in conformity with the approved drawings, Dredging of the trench shall be executed as accurately as possible.

3.1.2 The trench shall be excavated to such depth as required to provide the minimum cover and the pipeline configuration as specified. The pipeline profile of the crossings shall be followed as accurately as possible. Before laying, the trench shall be cleaned and leveled. The trench shall be subject to inspection COMPANY prior to installation of the pipe.

3.1.3 Navigational traffic shall not be obstructed, unless permission has been given thereto CONTRACTOR shall issue all necessary publications according to the local regulations instructions given by authorities shall be followed accurately and immediately, so that there in no hindrance to traffic. For stoppage of navigational traffic public notification, PA system, signal/ sign etc. shall be provided.

CONTRACTOR cannot request a compensation if his work is hampered or delayed due to weather conditions, any obstacles/ or by any traffic on the spool where work is executed.

3.1.4 CONTRACTOR is fully responsible for the execution of the blasting (whenever permitted) the dredging and excavation work. Hopping of the soil, transportation dumping on land or in water all to be executed in agreement with authorities, land owners and COMPANY.

3.1.5 CONTRACTOR may be obliged to dredge or excavate a trench deeper or wider than indicated in the drawings in order to properly lay the pipeline in unstable (underwater) areas, or near and adjacent to the banks of water courses. It shall be understood that CONTRACTOR is aware of such problems at the time of this bid and that, when such additional excavation is required it shall be done by CONTRACTOR as part of the work and that he will install the necessary provision and/or temporary works such as sheet-piling special filling materials, etc. at no extra cost to COMPANY.



Laying, Installation, Testing and Commissioning of 8” dia. Steel gas pipeline connectivity in PATAN GA



TENDER DOCUMENT NO
REPL/SGL/STPL/009/22

Date: -06/12/2022

3.1.6 During, the execution of dredging work of CONTRACTOR, bearings, measurements and levels shall be taken by or on behalf of COMPANY. CONTRACTOR shall render assistance for this purpose and make available for COMPANY appropriate survey boats, fully manned and equipped before the start of excavation work of the water crossing trench. CONTRACTOR if so desired by COMPANY, shall make cross profiles at intervals of not more than 10.0 m of the bottom of the water-course along the surveyed center line of the water crossing in such a case horizontal measurements shall be taken by triangulation or taping between known points and shall be made with such accuracy that the location of each vertical measurement is known within 1.0m Vertical measurements shall be taken with a sonic recording device, or with line and rod as directed by COMPANY and shall be taken with such accuracy that each depth is known within 0.2m Vertical measurements shall be taken at points averaging not more than 5.0m apart and no two measurements shall be more than 7.0 m apart The cross profiles shall extend at least 10m on both sides of the top of the trench

All measurements shall be witnessed by COMPANY The resulting profile, corrected to the elevation of the undisturbed water course shall then be the reference profile Said profile shall be plotted on a 1.200 vertical and horizontal scale.



3.1.7 CONTRACTOR shall keep the trench in good condition until the pipe is laid, and do claim is to be made to the COMPANY by reason of its caving either before or after the pipe is laid. CONTRACTOR shall do whatever is required to excavate the trench, install the pipe in it and backfill the trench in accordance with these specifications at no extra cost to COMPANY.

3.1.8 Immediately before installation of the water crossing in the excavated trench, CONTRACTOR shall prepare a profile of the trench bottom along the surveyed center line of the water crossing for comparison with the reference profile. CONTRACTOR shall also make cross sections of the trench at intervals of not more than 100m. All profile and cross section measurements shall be taken as specified and shall be witnessed by COMPANY. These data shall be submitted to COMPANY for approval and COMPANY will approve or reject the trench excavation as completed within 24 hours after receipt of the profile and cross sections.

3.1.9 CONTRACTOR shall grade the trench in such a manner as to give the maximum amount of uniform support to be pipeline when it is lowered or pulled into place. The maximum unsupported span shall not exceed 10.0m.

3.1.10 In submerged sections, where rock or gravel is encountered in the bottom of the trench, padding is required. The thickness of the padding under the concrete coated pipe shall at least be 50 cm and after installation at least 50 cm around the pipe.

3.2 Pumping line

	<p>Laying, Installation, Testing and Commissioning of 8” dia. Steel gas pipeline connectivity in PATAN GA</p>	
<p>TENDER DOCUMENT NO REPL/SGL/STPL/009/22</p>		<p>Date: -06/12/2022</p>

In case CONTRACTOR uses pumping lines to discharge the spoil, he shall take care of the necessary permits.

Pumping lines, discharges and siphons shall be installed by CONTRACTOR and removed before the completion of the work. At crossings with existing roads, the pumping lines shall be led through a casing pipe bored/ jacked under the road or led through a porch over the road. A stress calculation must then be handed over to COMPANY. The necessary provisions to embank the dumping area and also the spoil basins shall be made by CONTRACTOR, CONTRACTOR is responsible for transportation of the soil and dumping on land and is liable for damage to works of third parties caused by leakage of pumping lines, etc.

CONTRACTOR shall at all time prevent overflow of pumping water, spoil or sand over embankments, parcels or roads, Furtherm ore, CONTRACTOR shall safeguard COMPANY from claims of compensation by third parties due to encountered damage.

3.3 Spoil

Spoil which is not dumped on and including spoil acquired after cleaning the water crossing trench, shall be transported and dumped in places, designated there to by agreement between CONTRACTOR and authorities and approved of by COMPANY. Spoil shall be transported in (split) barges; only those barges shall be used that avoid spilling during transportation due to incorrect closing of the flaps. Etc. Spoil which is dumped outside the designated places shall be removed by CONTRACTOR at first notice by COMPANY.

Dykes, Dams and Weirs

CONTRACTOR shall install temporary provisions in the existing dykes, dams, etc. to prevent flooding of low areas.

Therefore, in general in existing dykes’ dams, etc. a double substituting weir must be installed before start of excavation in the existing dyke or dam. Such a double substituting weir can be a closed wall of sheet piling. Supported by soil. The provisions shall be such that the underwater profile of the dredged trench, the water movement caused by ships etc. cause noslides/ cave-ins of the dyke or dam.

4.0 **CONTINUOUS CONCRETE COATING**

CONTRACTOR shall provide concrete coating over the pipeline including the bends in accordance with the specification issued for the purpose (refer specification no SGL/TS/08/04A and approved procedure CONTRACTOR shall coat the weld joints in order to arrive at continuously concrete coated pipeline However this concrete coating shall be applied after the hydrostatic pretest.

5.0 **HYDROSTATIC PRE-TESTING**

CONTRACTOR shall hydrostatically pre-test the pipe string of each water crossing before installation as per approved procedure.



Laying, Installation, Testing and Commissioning of 8” dia. Steel gas pipeline connectivity in PATAN GA



TENDER DOCUMENT NO
REPL/SGL/STPL/009/22

Date: -06/12/2022

Joint coating of the welds shall be done after this pre-test.

The section of the pipeline corresponding to the major water crossing shall, before installation, be subjected to hydrostatic pre-testing to a combined equivalent stress of 90% of the SMYS of the pipe material

After the temperature has been stabilized, the pressure shall be maintained in the pipeline for at least twenty-four hours and recorded by man thermograph. During the test CONTRACTOR shall check all welds for leakage. Failure, if any, during the test shall be rectified by the CONTRACTOR. If the same is due to failure on account of any cause other than defect in material supplied by COMPANY, the repairs shall be done free of cost, to the satisfaction of COMPANY.

6.0 **INSTALLATION**

- 6.1 CONTRACTOR shall submit a detailed scheme for the method he proposes to adopt for installing the pipeline to COMPANY for approval. CONTRACTOR shall calculate all stresses in the pipeline while laying and check whether the stresses remain within permissible limits. A set of all calculations shall be submitted to the COMPANY for approval.
- 6.2 CONTRACTOR shall perform all work required to install the water crossings including the possible appurtenances indicated in the drawings. The water crossings shall be installed in such a manner as to comply with the requirements and conditions stated by the Authorities issuing the permits. CONTRACTOR shall pay special attention to minimize any damage to embankments and dykes in the vicinity of water crossings.
- 6.3 The equipment for launching shall be arranged in such a way that the pipeline is laid without impact or jerking and is not subjected to stresses of any type other than those which are allowable. Minimum allowed radius of curvature shall be followed particularly at the end of the launching way towards the water in the freely suspended section.
- 6.4 After the water – crossing section has been installed in place CONTRACTOR shall fill this section including the pertaining land sections with water for the final testing.
- 6.5 CONTRACTOR shall check if the position and depth of the water crossing are in accordance with the approved drawings, by means of a profile of the pipeline before and after the water – crossing section is filled with. CONTRACTOR shall lower each pipeline section which is not sufficiently deep by dredging or jetting the underLAYING ground.
- 6.6 The maximum allowed horizontal deviation from the required center line shall be limited to the following: -
- For Pipeline dia upto and including 24” – 300 mm
 - For Pipeline dia greater than 24 “ – 500 mm



Laying, Installation, Testing and Commissioning of 8” dia. Steel gas pipeline connectivity in PATAN GA



TENDER DOCUMENT NO
REPL/SGL/STPL/009/22

Date: -06/12/2022

6.7 Prior to backfill the pipeline shall when laid in the trench conform to the bottom contour of the trench grade so that it will be firmly, uniformly and continuously supported COMPANY may employ a diver or use other suitable methods to inspect the bottom of the trench and / or after the pipe is installed prior to backfilling of the trench. CONTRACTOR shall facilitate the work if the diver and shall furnish the necessary equipment and helpers (other than actual diving equipment) necessary for the diver / inspector to perform his work.

6.8 In the pipe does not properly fit the trench or does not rest at sufficient depth to satisfy the minimum requirements of cover as specified in approved drawing, the CONTRACTOR shall make necessary corrections to either trench or the pipe alignment or to both so that the pipe, when finally in position in the trench, shall fully meet the specifications, failing which CONTRACTOR may be asked to remove the pipeline. This shall be done at no extra to the COMPANY.

6.9 Installation of Parallel Pipelines

When parallel pipelines are required to be installed for a major water crossing CONTRACTOR shall further comply with the following requirements.

6.9.1 Depending on the diameters of the parallel pipelines, the characteristics of the crossing and the limitations of CONTRACTOR’S equipment, CONTRACTOR may propose installation of the parallel pipelines either together in a combined operation or separately in a common trench.

6.9.2 If the pipelines are installed together, the minimum clear distance between the parallel pipelines (measured from the outside diameters of the concrete coated pipes) shall be 300 mm. CONTRACTOR shall provide spacers at sufficient intervals along the length of the pipe section (s), securely fixed to the pipes, or shall propose other suitable alternative methods, so as to ensure that the stipulated minimum clear distance is maintained. The spacers may be removed before the trench is backfilled.

CONTRACTOR shall furnish detailed drawings for the pipe assembly showing the details of spacers / other arrangements for COMPANY’S approval starts of construction.

6.9.3 If the parallel pipelines are installed separately in common trench, the minimum clear distance between the parallel pipeline in the trench shall be 500 mm. CONTRACTOR shall ensure that this minimum spacing be maintained till the time the trench is backfilled.

6.0 BACKFILLING AND BANK PROTECTION

6.1 Backfilling of the water - crossing section shall be performed as described in the following clauses.

6.1.1 The bottom of the waterway shall be reinstated to its original level by backfilling the trench in a manner and with suitable material and as prescribed and approved



Laying, Installation, Testing and Commissioning of 8” dia. Steel gas pipeline connectivity in PATAN GA



TENDER DOCUMENT NO
REPL/SGL/STPL/009/22

Date: -06/12/2022

by the authorities and COMPANY. In case material other than the original spoil is required, this shall be supplied and applied by CONTRACTOR.

Wherever boulders, rock, gravel and other hard object are encountered, they shall not be placed directly on the pipe. Sufficient earth, and or selected and approved backfill material shall be backfilled initially around and over the pipe to provide a protective padding or cushion or cushion extending to a minimum thickness of 50 centimeters around the pipe before backfilling remainder of the trench with excavated or other material.

Wherever required by COMPANY, CONTRACTOR shall cover the (nearly) backfilled trench with a layer of rock boulders to be approved by COMPANY over a width equal to the width of the excavated trench with an extra of 5 m on either side at no extra cost to COMPANY.

- 6.1.2 Backfilling progress of the trench shall be checked continuously, and a daily progress report shall be made and handed over to COMPANY
- 6.1.3 All embankment and/or dykes, bed and banks shall be reinstated to their original state and levels unless otherwise prescribed in the drawings or by the competent authorities of COMPANY.
- 6.1.4 All remaining spoil – deposits shall be cleaned by CONTRACTOR to the satisfaction of COMPANY.

6.2 Bank protection

- 6.2.1 Trenches in banks of major water crossing shall be backfilled with soil approved by COMPANY. The fill at the banks shall be temped firmly and reinforced with sacked earth, rip-rap, or by other means as directed by COMPANY to the satisfaction of authorities having jurisdiction thereof, In areas where the backfilled soil is expected to be of loose type which is prone to flow, the trench shall be backfilled with boulder/ crushed rock of minimum 75mm thickness. The boulder/ crushed rock shall be derived from solid, stable, non-soluble and approved quality store approved by COMPANY and pipe shall be provided with adequate padding of soil of a quality approved by COMPANY, Wherever necessary the boulder/ crushed rock shall be held to the bed by use of 6.1 wire nets of minimum dia of 3.2mm made from steel having tensile strength of 400 N/mm and with a minimum elongation at failure of 12% The minimum zinc coating of 275 gm 2 shall be applied on single/ double twisted wire. After the trench has been backfilled and during the clean up works, the water crossing shall be cleaned across the whole width of ROW. The existing bed profile shall be maintained after restorations.
- 6.2.2 Unless stipulated otherwise by the authorities or by COMPANY, CONTRACTOR shall protect the banks of the major water crossings by using gravel and boulders filled embankment mattresses of galvanized iron wire (of specification as in 7.2.1 above) to be laid over the backfilled, compacted and graded banks. In case stop of the banks is 1.1 or more, bank protection shall be carried out using gabions. Bank protection works shall be carried out by CONTRACTOR in accordance with the drawings included in the CONTRACT. All materials required for such works shall be supplied by CONTRACTOR and all works carried out in accordance with



Laying, Installation, Testing and Commissioning of 8” dia. Steel gas pipeline connectivity in PATAN GA



TENDER DOCUMENT NO
REPL/SGL/STPL/009/22

Date: -06/12/2022

specifications, approved drawings, instructions of COMPANY and to the complete satisfaction of authorities having jurisdiction at no extra cost to COMPANY.

The length of the above protection shall be equal to the actual bank excavation edge including damage and further extending 10 m on either sides, The width of the restoration on the slope shall be determined by the levels

- 2m above Highest Water level, (recordable) or upto the top of bank whichever is higher
- 5m below Low Water level(recordable) or upto pipe trench level in their bed.

6.2.3 Before final hydrostatic testing, CONTRACTOR shall „prove” the diameter of the pipeline by passing a gauging (caliper) pig through the pipeline. The gauging pig shall have a diameter equal to 95% of the internal diameter of the pipe.

CONTRACTOR shall supply and install all temporary scraper, launchers, Receivers and other equipment, piping and materials and consumable for the purpose.

8.0 FINAL HYDROSTATIC TEST

The complete water crossing must be tested immediately after the approved backfilling of the trench. The test procedure shall result in a hoop stress in pipe corresponding to 90% SMYS of the pipe material. After temperature stabilization pressure shall be retained in the pipeline for a minimum of 4 hours and recorded by man thermograph. The hydrostatic testing shall be carried out in accordance with approved procedures.

9.0 POST – CONSTRUCTION SURVEY

After laying of the pipeline, Contractor shall carry out a post construction survey jointly with COMPANY. Any defects brought to the notice of CONTRACTOR shall be promptly corrected by CONTRACOT at his own expense to the complete satisfaction of COMPANY.

10.0 FINAL CLEAN-UP

After completion of construction CONTRACTOR shall clear the site of all balance material and debris. All balance pipe lengths, in case supplied by COMPANY shall be returned to COMPANY’S designated stock yard(s). Site shall be cleared to the complete satisfaction of COMPANY and authorities having jurisdiction. All such works shall be done at no extra cost to COMPANY.

11.0 DOCUMENTATION

11.1 In addition to the documents specified elsewhere in this specification CONTRACTOR shall submit to the COMPANY six copies of each of the following documents / records.



Laying, Installation, Testing and Commissioning of 8” dia. Steel gas pipeline connectivity in PATAN GA



TENDER DOCUMENT NO
REPL/SGL/STPL/009/22

Date: -06/12/2022

- Complete record of pipes „taken – over „, from COMPANY, number of pipe lengths used, and record of return of balance pipe lengths to COMPANY’S designated stock – yard(s)
- Copies of the permits obtained from authorities having jurisdiction for the various work.
- Record of Non-destructive testing welds.
- Clearance certificates from the land owners and authorities having jurisdiction regarding satisfactory clean – up and restoration of pipeline ROU and work areas.

11.2 After completion of construction CONTRACTOR shall prepare & furnish six sets of copies and two sets of reproducible of As built drawing for the crossing.

As built drawing shall be as a minimum include the following information.

- True profile of the bed and banks of the water crossing along the pipeline after backfilling.
- True profile of the pipeline as installed and the top of cover to top of pipe at regular intervals.
- Location and angle of sag and over bends.
- Extent of backfill.
- Extent of bank protection.

11.3 All documents shall be in English Language.

12. PERMISSIONS

Pipeline laying liaisoning (including crossings) and getting permission, NOC and SD Refund form the various statutory authorities. Submitting request for (after obtaining the letter from client) permission follow up, assisting in site inspections/ route survey/ site report making/making site inspection drawings, submitting at designated offices resubmission after correction, modification if required, soft and hard copy in nos. as required / if required in sizes, and collecting final permission from the various statutory authorities including NHAI, PWD Railways, Irrigation, Forest, Municipal Corporation etc. Obtaining work permits form various statutory authorities having jurisdiction before execution of the work and complying with all stipulations/conditions/recommendation of the said authorities. And obtain NOC and SD refund from authorities after completion of work. Only statutory fees shall be paid by the owner.



Sabarmati Gas Ltd.

(A Joint Venture of GSPC and BPCL)

SABARMATI GAS LIMITED

**LAYING, INSTALLATION, TESTING AND COMMISSIONING OF 8”
DIA. STEEL GAS PIPELINE CONNECTIVITY IN PATAN GA**

RESONANCE ENERGY PVT. LTD.

**Pipeline Crossing Roads, Railroads, Minor Water and Other
Crossings**

Tender No. REPL/SGL/STPL/009/21

0	25/11/2022	Issued for RFP	AS	PG	PC
Rev.	Date	Description	Prepared By	Checked By	Approved By



**Laying, Installation, Testing and
Commissioning of 8” dia. Steel gas
pipeline connectivity in PATAN GA**



TENDER DOCUMENT NO
REPL/SGL/STPL/009/22

Date: -06/12/2022

C O N T E N T S

- 1.0 SCOPE
- 2.0 GENERAL
- 3.0 ROAS AND RAIL – ROAD CROSSINGS
- 4.0 CROSSINGS OF BURIED SERVICES
- 5.0 MINOR WATER COURSE CROSSINGS
- 6.0 PERMISSIONS



Laying, Installation, Testing and Commissioning of 8” dia. Steel gas pipeline connectivity in PATAN GA



TENDER DOCUMENT NO
REPL/SGL/STPL/009/22

Date: -06/12/2022

1.0 SCOPE

1.1 This specification covers the minimum requirement for the various activities to be carried out by the CONTRACTOR for or about the installation of pipelines crossing roads, railroads, minor water courses and other services.

The provisions of this specification are not applicable for pipeline crossing water courses, which are specifically designated as “Major Water Courses” in the CONTRACT.

1.2 This specification shall be read in conjunction with conditions of all specifications and documents included in the CONTRACT between COMPANY and CONTRACTOR.

For the purpose of this specification the following definitions shall hold:

- The words “ Shall “ and “Must” are mandatory
- The words “Should, “May” and “Will” are non – mandatory, advisory recommended

2.0 GENERAL

2.1 Crossing of roads, railroads, buried services, canals and minor water courses with equipment and / or personnel is allowed only acquiring approval from the authorities having jurisdiction and after making arrangements for safeguarding roads, etc. And the buried services with appropriate provisions.

Highways, main – roads and railroads and their verges and banks of water crossings are not allowed to be used loading unloading or stacking of materials and / or equipment. For secondary roads, such loading/ unloading is permitted only after prior approval from the concerned authorities CONTRACTOR is not allowed to close or divert roads or water courses without prior approval from the COMPANY and the concerned authorities. CONTRACTOR shall never unnecessarily hamper the users of the roads, railroads, buried services and/ or water courses. The water flow shall not be



Laying, Installation, Testing and Commissioning of 8” dia. Steel gas pipeline connectivity in PATAN GA



TENDER DOCUMENT NO
REPL/SGL/STPL/009/22

Date: -06/12/2022

obstructed in any way.

2.2 COMPANY reserves the right to demand for individual crossings from the CONTRACTOR a separate detailed report for approval, containing:

- Time schedule
- Working method with equipment
- Test procedure
- Manpower deployment
- Calculations of temporary works
- Soil investigations, etc.

Such works shall be without any extra cost to COMPANY.

2.3 Pipeline crossings for road, railroad canals and rivers etc., shall be hydrostatically pre-tested ex – situ, prior to joint coating, whenever,

- Crossing is executed by boring ;
- Crossing is installed in casing pipe ;
- River crossing pipes which are to be continuously concrete weight coated (to be tested prior to concrete coating);
- Whenever in COMPANY’S opinion the repair of pipeline at crossing in case of a leak during final hydrostatic testing would require inordinate amount of effort and/ or time
- Whenever pre-testing is insisted upon by the Authorities having jurisdiction over the utility crossed.

The section of the pipeline for the crossings shall be tested as a single string. Unless specified otherwise in the CONTRACT, the test pressure shall be the one resulting in a hoop stress corresponding to 90% of SMYS of pipe material. Test pressure shall be retained in the pipeline for minimum period of 6 hours. Test section shall be visually examined for leaks / defects, etc.

3.0 **ROAD AND RAILROAD CROSSINGS**

3.1 The work under crossings shall include necessary clearing, grading and trenching to required depths and widths welding of casing (when required) and carrier pipes, coating lowering – in backfilling clean – up restoration to



Laying, Installation, Testing and Commissioning of 8” dia. Steel gas pipeline connectivity in PATAN GA



TENDER DOCUMENT NO
REPL/SGL/STPL/009/22

Date: -06/12/2022

the original condition and further strengthening and protective work testing, installation of assemblies, insulators and seals, and temporary work such as sheet piling bridges etc.

The work shall be carried out in accordance with the approved drawing and job standards as directed by COMPANY and to the satisfaction of COMPANY and the authorities having jurisdiction over the facility crosses. The work carried out for road and railroad crossings shall meet the minimum requirements of APL RP 1102 latest edition.

Before the installation work of crossings is started the CONTRACTOR shall provide suitable barricades, temporary bridge / bypass work (especially where roads are open-cut) with railing if required by COMPANY for safety of traffic. Adequate traffic warning signals and / or traffic lights and suitable diversions shall be provided as directed by COMPANY / Authority having jurisdiction over these areas. Such diversions shall not cross the pipeline where it has already been installed unless proper safeguarding in COMPANY’S opinion is ensured.

Prior approval from the statutory authorities shall be obtained to lay the pipeline across highways / roads either by boring or by open – cut method. Installation of the crossing shall be by the method (i.e., boring / open-cut) approved by Authorities having jurisdiction. Railroad crossings shall always be bored/ jacked.

3.2

Boring / jacking of carrier pipes for crossings is allowed only if the pipes for boring/ jacking are provided with a suitable corrosion coating and CONTRACTOR remains liable for the suitability of the pipe and weld-coating of carrier pipes to be bored and for which coating and method of application are anyhow to be authorized by COMPANY.

Before start of the boring/ jacking CONTRACTOR shall execute a soil investigation and determine the ground water table. Based on these investigations CONTRACTOR shall prepare a construction drawing and submit to COMPANY for approval including time schedule and soil investigation report. The CONTRACTOR shall submit for approval of



Laying, Installation, Testing and Commissioning of 8” dia. Steel gas pipeline connectivity in PATAN GA



TENDER DOCUMENT NO
REPL/SGL/STPL/009/22

Date: -06/12/2022

COMPANY the method of boring / trench less to be carried out, depending on the nature of soil conditions, nature of crossing local requirements etc.

During the execution of boring the ground water over the length of the boring shall be lowered up to at least 0.50 M below bottom of the pipeline. This water table is to be regularly inspected and maintained by CONTRACTOR and reported to COMPANY. To safeguard the stability of the bore pit, CONTRACTOR shall, if necessary in COMPANY’S opinion use a closed sheet piling which shall extend at least over 50% of the length in undisturbed soil. The length of the boring shall be in accordance with the length of the ROW of the crossing (road, railroad, etc.) with minimum 0.6 m extra on either side.

If the soil conditions and groundwater for a particular boring give reasons for this, CONTRACTOR is entitled to suggest to COMPANY for a relaxation of one or more of the following requirements as defined here forth :

- Soil investigation
- Lowering of groundwater table
- Sheet piling
- Length of boring etc.

In approaches to the crossing, CONTRACTOR shall eliminate unnecessary bending of pipe by conforming to the contour of the ground by gradually deepening the ditch at such approaches as directed by the COMPANY

3.3 The bottom of the trench and / or the pit at least twelve (12) meters at the approach to each end of a casing shall be graded and if necessary backfilled with clean sand and compacted unto at least 95% Proctor density to an elevation that will provide sufficient and continuous support to the pipeline so that the pipeline remains correctly aligned at the casing ends during and after backfilling.

3.4 The diameter of the hole for bored section shall have a hole diameter as close as practicable to the outside diameter of the carrier or casing pipe. If excessive void or too large hole results, or if it is necessary, in the opinion



Laying, Installation, Testing and Commissioning of 8” dia. Steel gas pipeline connectivity in PATAN GA



TENDER DOCUMENT NO
REPL/SGL/STPL/009/22

Date: -06/12/2022

of COMPANY, to abandon the bored hole, prompt remedial measures such as filling the hole with suitable material shall be taken to the entire satisfaction of the COMPANY and Authorities having jurisdiction thereof at no extra cost to COMPANY. Equipment used for installation of casing pipe shall be of the type approved by COMPANY.

An installation consisting of hydraulic jacks shall be provided with easily readable pressure gauges (in bar) and sealable pressure limits. Their proper operation shall be demonstrated before the work is started. COMPANY can request that maximum pressing force be limited.

At the front of the pipe there may be a cutting ring which may be 12 mm larger than the outside diameter for the pipe or casing. A lubricating pipe can also be used in jacking the nipples of which shall not protrude from the cutting edge. Said lubricating pipe shall not be fixed to the pipe casing. When jacking Only biologically degradable lubricants shall be used (E.D. WRC Med lube or an emulsion of betonies)

Removal of soil from the pipeline during jacking shall be done mechanically by means of a standard, locked auger, which has to be safeguarded against jacking ahead of the pipe.

During jacking the progress of the pipe to be jacked and the cutting capacity of the auger shall be mutually adjusted by regulation the speed of the auger; to prevent the road from bulging (rpm too low) or cave – ins (rpm too high). In any case on more soil shall be removed than the volume of the pipe. The auger drive shall be provided with a clutch.

If the jacking fails the casing shall not be withdrawn. It shall be filled with sand and plugged at either end.

Casing at crossings, when provided to meet statutory requirements, shall be designed in accordance with API 1102. Casing pipe diameter shall be minimum two pipe sizes bigger than carrier pipe.

COMPANY reserves the right to inspect certain lengths of pipes to assess damages, if any, to the corrosion coating of the carrier pipe used for boring. CONTRACTOR shall weld additional lengths of pipe and pull the required



Laying, Installation, Testing and Commissioning of 8” dia. Steel gas pipeline connectivity in PATAN GA



TENDER DOCUMENT NO
REPL/SGL/STPL/009/22

Date: -06/12/2022

extra lengths of COMPANY'S inspection. If during inspection, any defects are noticed CONTRACTOR, in consultation with COMPANY, shall carry out the remedial measures required.

- 3.5** While welding of the casing and vent / drain pipes, internal high or low is not allowed. Welding of casing and vent/ drain pipes need not be radiographed however, only normal visual checks shall be carried out. Before welding, the single length of pipe shall be inspected in order to check that is no out of roundness and dents. When such defects are noticed, there must be completely removed before joining the pipes. If these defects cannot be repaired, the defective section shall be cut out.
- 3.6** In the case of crossing where excavation has authorized, the welding for the casing pipe and for a continuous section of the pipeline corresponding to the expected length shall be carried out in the proximity of the crossing. Casing must be laid immediately after the trenching. Casing pipe must be laid with a single gradient in order to allow for an easy insertion and, if necessary at a future date, to allow for the removal or replacement of the pipeline, leaving the casing undisturbed.
- 3.7** The assemble of vent units as approved by COMPANY shall be carried out by direct insertion and welding to the ends of the casing pipe before introducing the carrier pipe. The operation of assembling and extending the vent pipe shall be carried out in such a way that there is no contact with the carrier pipe. The painting / coating of the vent pipes shall be applied before backfilling as per relevant specifications.
- 3.8** The casing pipe shall be considered ready for installation of the carrier pipe after careful inspection and internal cleaning with the removal of soil, mud, stones and other foreign materials.
- 3.9** Insulators, as approved by COMPANY, shall be securely fastened to the pipe with all bolts and fixtures firmly tightened. The number of insulators and spacing shall be as shown in the drawings or at 2.5 m intervals (whichever is more stringent). At the end of both sides of the casing, a double set of insulators shall be installed.
- 3.10** Care must be taken in pushing or pulling carrier pipe into the casing so that



Laying, Installation, Testing and Commissioning of 8” dia. Steel gas pipeline connectivity in PATAN GA



TENDER DOCUMENT NO
REPL/SGL/STPL/009/22

Date: -06/12/2022

the pipe is aligned correctly in the casing and that the pushing or pulling force is evenly and constantly applied to avoid damages to the insulators. A nose piece having a diameter equal to that of the pipe shall be welded on the front and back end of the carrier pipe to facilitate installation of the carrier pipe properly in the casing and to keep it dry and clean.

- 3.11** After installation of the carrier pipe section, the casing and the appurtenances, but prior to making tie-in welds and backfilling, an electrical test shall be conducted by the CONTRACTOR in the presence of the COMPANY to determine the resistance between the casing and the carrier pipe or the carrier pipe and the soil. These tests shall show at test a resistance of 100 k-ohm/m². After backfilling and compaction, additional tests shall be conducted to determine if the casing is electrically shorted to the pipe. If the installation is found to be shorted, CONTRACTOR shall make the necessary corrections and repairs at his cost, until a test to the satisfaction of the COMPANY is obtained.

4.0 CROSSINGS OF BURIED SERVICES

- 4.1** The pipeline under construction may pass above or below the existing buried facilities such as pipeline, cables, etc. Type of crossing shall be such that a minimum depth of cover as required in the drawings and specifications are guaranteed. The minimum clearance required between pipeline and the existing facility shall be 500 mm

- 4.2** Whenever buried services in the ROW are to be crossed by CONTRACTOR, he shall safeguard the buried facilities and the required precautions shall be taken as approved by Owner of the buried services and by COMPANY.

- 4.3** For buried services to be crossed by boring / jacking the relevant provisions of Section 3.0 shall apply.

5.0 MINOR WATER COURSE CROSSINGS

- 5.1** Minor water crossings are crossings of ditches canals, water courses, rivers, streams etc, whether the bed(s) contain(s) water or not, and not being specified as „Major Water Crossings“ in the CONTRACT.

- 5.2** For minor water crossings a standard drawing or a separate detailed



Laying, Installation, Testing and Commissioning of 8” dia. Steel gas pipeline connectivity in PATAN GA



TENDER DOCUMENT NO
REPL/SGL/STPL/009/22

Date: -06/12/2022

approved drawing for individual crossing shall be applicable, and all further specifications are applicable.

- 5.3** Whenever minor water crossings in the ROW are to be crossed, CONTRACTOR shall install / temporary bridges to facilitate movement.
- 5.4** In crossings of water courses with either moderate flow rate or of torrential nature with marked and unpredictable flooding, anadequate survey shall be carrier out before starting the work with the object of determining what precautions are necessary and the most favorable period for executing the work.
- 5.5** In case of crossings of water courses for which no special methods of laying are required, a pipe section of a size as per the approved drawings shall be assembled and subsequently laid. Bends shall be of cold field type. Wherever required by COMPANY CONTRACTOR shall before start of construction execute a soil investigation. Based of this soil investigation he shall prepare construction drawings, work method and time schedule for approval of COMPANY as well as concerned local agencies.

The depth of the existing bottom of a minor water course crossing shall be determined in relation to the adjacent stable ground level by taking the average of four measurements. Measurements shall be taken with a gauge and with dimensions 60 × 60 mm and having a flat bottom. The minimum force to be exerted shall be 360 N (36 kgf)

CONTRACTOR shall take special care to check with the responsible authorities for special conditions applying to working on, over under or through minor water crossings and CONTRACTOR shall comply with any such conditions. Written arrangements with authorities shall be drawn up in cooperation with COMPANY.

- 5.7** For crossings beneath the bed of water courses, the pipe section shall be made in such a way that it conforms to the existing or future bed as indicated in the approved drawings. In crossings for which an individual drawing has not been prepared the minimum cover of the pipeline shall not be less than that indicated in the standard drawings for a similar type of



Laying, Installation, Testing and Commissioning of 8” dia. Steel gas pipeline connectivity in PATAN GA



TENDER DOCUMENT NO
REPL/SGL/STPL/009/22

Date: -06/12/2022

crossing

- 5.8 Whenever the crossing requires a straight section of pipe between the lower bends coinciding with the river bed, this section shall be laid at a single horizontal level.
- 5.9 For crossings of ditches canals, banked channels, etc by boring the pipe section shall be prepared laid and tested in accordance with the applicable clauses of Section 3.0 of this specification.
- 5.10 The CONTRACTOR shall arrange temporary installation of diversions as may be necessary to ensure the entire satisfaction of the concerned Local Authorities as well as the COMPANY.
- 5.11 Banks and trenches of minor water crossings shall be backfilled with soil which it to be approved by COMPANY and shall be thoroughly compacted to prevent soil and bank erosion as per the drawings and standards to the satisfaction of authorities having jurisdiction thereof and the COMPANY. Whenever boulders, rock, gravel and other hard objects are encountered, they shall not be placed directly on the pipe. Sufficient earth, sand or selected and approved backfill material shall be backfilled initially around and over the pipe to provide a protective padding or cushion extending to a minimum thickness of 30 centimeters around the pipe before backfilling remainder of the trench with excavated or other material as per approved drawings and standards.
- After the trench has been backfilled and during the clean up work, the minor water crossing shall be cleaned at least across the whole of the ROW.
- When directed by the COMPANY, CONTRACTOR shall stabilise and restore the bank of the water crossings with materials to be supplied by him as follows.
- The excavation shall be trimmed in steps – and – berms backfilled with well compacted solid soil, followed by a minimum 0.25 m thick layer of properly shaped boulders (75-150mm) encased in a net of galvanised iron wire of dia 3 mm spaced at a maximum distance of 50 mm to be laid over the backfilled, compacted and graded banks.
- The GI wire shall be made from steel having tensile strength of 400 N/mm²



Laying, Installation, Testing and Commissioning of 8” dia. Steel gas pipeline connectivity in PATAN GA



TENDER DOCUMENT NO
REPL/SGL/STPL/009/22

Date: -06/12/2022

and with a minimum elongation at failure of 10%. The minimum zinc coating of 200 gm² shall be applied on single / double twisted wire.

The length of the above protection shall equal to the actual bank excavation edge including damage and extending 2 m on either side. The width of this protection on the slope shall be determined by the following:

- 2m plus the highest water level (recoverable) or upto the top of bank whichever is higher.
- Upto the bottom of the crossing or 20 m below the highest water level whichever is smaller.

Bank stabilization for certain minor water crossings shall be determined by COMPANY based on nature of crossing e.g. type of river, canal, major nallah flood control banks and other water bodies; type of soil, regulations of local authorities; and any other socio- economic consideration evaluated by the COMPANY.

5.12 The crossing of any embankments shall be carried out strictly in accordance with approved drawings.

No drilling work on embankments shall be permitted without prior written approval from the competent authorities.

6.0 PERMISSIONS

Pipeline laying liasioning (including crossings) and getting permission, NOC and SD Refund form the various statutory authorities. Submitting request for (after obtaining the letter from client) permission follow up, assisting in site inspections/ route survey/ site report making/making site inspection drawings, submitting at designated offices resubmission after correction, modification if required, soft and hard copy in nos. as required / if required in sizes, and collecting final permission from the various statutory authorities including NHAI, PWD Railways, Irrigation, Forest, Municipal Corporation etc. Obtaining work permits form various statutory authorities having jurisdiction before execution of the work and complying with all stipulations/conditions/recommendation of the said authorities. And obtain NOC and SD refund from authorities after completion of work. Only statutory fees shall be paid by the owner.



Sabarmati Gas Ltd.

(A Joint Venture of GSPC and BPCL)

SABARMATI GAS LIMITED

**LAYING, INSTALLATION, TESTING AND COMMISSIONING OF 8"
DIA. STEEL GAS PIPELINE CONNECTIVITY IN PATAN GA**

RESONANCE ENERGY PVT. LTD.

**Specification for Field Joint Coating
Tender No. REPL/SGL/STPL/009/22**



**Laying, Installation, Testing and
Commissioning of 8” dia. Steel gas
pipeline connectivity in PATAN GA**





TENDER DOCUMENT NO
REPL/SGL/STPL/009/22

Date: -06/12/2022

CONTENTS

1.0	SCOPE
2.0	REFERENCE COCUMENTS
3.0	MATERIAL AND EQUIPMENT
4.0	APPLICATION PROCEDURE
5.0	INSPECTION & TESTING
6.0	REPAIR
7.0	DOCUMENTATION

	Laying, Installation, Testing and Commissioning of 8” dia. Steel gas pipeline connectivity in PATAN GA	
TENDER DOCUMENT NO REPL/SGL/STPL/009/22		Date: -06/12/2022

1. **SCOPE**

This Specification covers the minimum requirements of materials, equipment and installation of field joint anti-corrosion coating of buried onshore pipelines factory coated with either three layer polyethylene of fusion bonded epoxy coating, byheat shrink wraparound sleeves or by cold applied tapes conforming to DIN EN 12068- “Cathodic Protection - External Organic Coatings for the Corrosion Protection of Buried or Immersed Steel Pipelines used in Conjunction with Cathodic Protection Tapes and Shrinkable materials” and the requirements of this specification. Unless modified/ replaced by this specification, all requirements of DIN EN 12068 shall remain fully applicable and complied with.

This specification shall be read in conjunction with the conditions of all specifications and documents included in the Contract between COMPANY and CONTRACTOR. Unless specified otherwise, all section of this specification shall apply to all specifications referred in this specification.

2. **REFERENCE DOCUMENTS**

Reference has been made to the latest edition (edition enforce at the time of floating the enquiry) of the following standards, codes and specification:

- a) **ASTM D-149:** Standard Test Methods of Dielectric Break- down voltage and Dielectric Strength of solid electrical insulating materials at commercial frequencies.
- b) **ASTM D-257:** Standard Test Methods for D-C Resistance for conductance of insulating materials.
- c) **ASTM D-570: Standard Methods of Test for Water Absorption of Plastics**



Laying, Installation, Testing and Commissioning of 8” dia. Steel gas pipeline connectivity in PATAN GA



TENDER DOCUMENT NO
REPL/SGL/STPL/009/22

Date: -06/12/2022

d) **ISO 8502-3:** Preparation of steel Substrates before Application of Plastics-

Part-3-Assessment of Dust on Steel Surfaces Prepared for Painting (Pressure Sensitive Tape Method).

e) **ISO: 8503-1: Part-1:** Specification and definitions for ISO surface profile comparator for the assessment of abrasive blast cleaned surfaces.

f) **ISO: 8503-4:** Part-4: Methods for calibration of ISO surface profile comparator and for the determination of surface profile - Stylus instrument procedure.

g) **SIS-055900:** Pictorial surface Preparation Standard for Painting Steel Surfaces.

h) **SSPC-SP 1:** Steel Structure Painting Council.

In case of conflict between the requirements of this specification and that of above referred documents, the requirements of this specification shall govern.

The Contractor shall be familiar with the requirements of these documents and shall make them readily available at the side to all personnel concerned with carrying out the works specified in this specification.

3. **MATERIALS AND EQUIPMENT**

3.1 **Field Joint Corrosion Coating Material**

Field joint anti-corrosion coating material shall be either heat shrinkable wraparound sleeve or cold applied tape suitable for a maximum operating temperature of (+) 60° C (T_{max}) and shall conform to designation EN 12068- CHT 60 UV. In addition the field joint anti-corrosion coating shall comply the requirements specified in para 3.2 of this specification.



Laying, Installation, Testing and Commissioning of 8” dia. Steel gas pipeline connectivity in PATAN GA



TENDER DOCUMENT NO
REPL/SGL/STPL/009/22

Date: -06/12/2022

3.1.1 Heat Shrinkable Wraparound sleeve

Heat shrinkable wraparound sleeve shall consist of radiation - cross-linked thermally stabilised, ultraviolet resistant semi-rigid polyolefin backing with a uniform thickness of high shear strength thermoplastic/ copolymer hot melt adhesive. The joint coating system may consist of a solvent free epoxy primer applied to the pipe surface prior to sleeve application. The backing shall be coated with thermochrome paint which will change colour when the desired heat during shrinking is attained. The wraparound sleeve shall be supplied in pre-cut sizes to suit the diameter and the requirements of overlap.

The total thickness of heat shrinkable wraparound sleeve in the as applied condition shall be-as follows:

Pipe size (Specified Outside Diameter)	Thickness (mm)		
	On pipe Body		On Weld Bead (Min.)
	Average	Min	
Upto 103/4” (273.1 mm)	2.0	1.8	1.6
Over 103/4” (273.1 mm) to below 20” (508.0mm)			
From 20” (508.0mm) to below 32” (813.0 mm)			
From 32” (813.0mm) and above	2.4	2.2	2.0

The heat shrink wraparound sleeve shall have the required adhesive properties when applied on various commercial pipe-coating materials. The pre-heat and application temperatures required for the application of the shrink shall not cause loss of functional properties of the pipe coating.

Heat shrink wraparound field coating system manufactured by M/s Tyco Adhesives - Raychem and M/s Canusa are acceptable for the supply of field joint coating materials. The contractor shall propose the specific grade of field joint coating system meeting the requirements of this specification from these manufacturers. In case the contractor proposes to supply heat shrink wraparound sleeve from any other manufacturer, then the contractor shall propose only those coating systems that have been previously used in pipelines of similar size and operating conditions.

3.1.2 Cold Applied Tapes

Cold applied tapes system shall comprise of primer, an inner wrap and an outer wrap. The inner and outer wraps shall be asymmetric 3-ply tape with co-extruded polyethylene carrier film and butyl rubber adhesive layers on both sides. The inner layer of butyl rubber adhesive of inner wrap shall have a thickness of min.1.0mm. The inner and outer wraps are to be spirally wrapped with 55% overlap, equivalent to two layers each providing a total minimum thickness of 3.0 mm on the pipe body and 2.5mm on the weld.



Laying, Installation, Testing and Commissioning of 8” dia. Steel gas pipeline connectivity in PATAN GA



TENDER DOCUMENT NO
REPL/SGL/STPL/009/22

Date: -06/12/2022

The Contractor shall propose only those cold applied tape coating systems that have been previously used in pipelines of similar size and operating conditions.

3.2 Functional Requirements of Field Joint Coating

3.2.1 Properties of the PE backing shall be as follows:

Sl. No.	Property	Unit	Requirement	Test Method
a)	Tensile Strength at @+25°C	N/mm	>12	DIN EN 12068
b)	Ultimate Elongation @+25°C	%	> 250	DIN EN 12068
c)	Dielectric withstand with 1000 Volts / sec	kv	> 30	ASTM D 149
d)	Water absorption @+25°C for 24 hours	%	< 0.05	ASTM D 570
e)	Volume Resistivity @+25°C	Ohm-cm	> 10	ASTM D 257

3.2.2 Functional Properties of Joint Coating System (As applied)

As applied field joint coating system shall the requirements of DIN EN 12068. Table 1 and 2 corresponding to designation DIN EN 12068 - C HT 60 UV, except as modified below :

a) Cathodic Disbondment Resistance at T_{max} i.e. 60° C shall be 20mm when tested as per Annexure K of DIN EN 12068. Test shall be carried out (+)60°C.

b) Peel strength shall be as follows:

Peel strength		Unit	Requirement for Mech Resistance Class C (Minimum)	Test method as per DIN EN 12068
Inner to Inner + Outer to Inner	@23 ⁰ C	N/mm	1.5	Annexure-B
	@T _{max}	N/mm	0.3	
Outer to outer	@23 ⁰ C	N/mm	1.5	
	@T _{max}	N/mm	0.3	
To pipe surface	@23 ⁰ C	N/mm	3.5	Annexure-C
	@T _{max}	N/mm	0.3	
To factory coating	@23 ⁰ C	N/mm	3.5	
	@T _{max}	N/mm	0.3	

(T_{max} shall be (+) 60⁰ C)



Laying, Installation, Testing and Commissioning of 8” dia. Steel gas pipeline connectivity in PATAN GA



TENDER DOCUMENT NO
REPL/SGL/STPL/009/22

Date: -06/12/2022

Contractor shall obtain approval from company regarding the manufacture of the joint coating material. Complete technical details along with test certificates complying with the requirements of clause 3.2.1 and 3.2.2 shall be submitted to company for this purpose. The contractor shall furnish test certificates from an independent DIN recognized / approved laboratory for all the properties required for the specified EN designation of field joint coating and the requirements of this specification.

- 3.3 The materials shall not be older than their period of validity at the time of application by CONTRACTOR. Deteriorated / decomposed material shall be disposed of and replaced by CONTRACTOR at his own expense.

CONTRACTOR shall ensure that the coating materials supplied by are properly packed and clearly marked with the following.

- Manufacturer's name
- Material qualification
- Batch number
- Date of manufacturing and date of expiry.

- 3.4 CONTRACTOR shall ensure that the manufacturer has carried out all quality control tests on each batch and manufacturer shall provide test certificates to certify that the supplied materials meet the manufacturer's specifications as indicated in the purchase order and as approved by COMPANY and data sheets certifying the qualities of the coating materials shall be submitted by CONTRACTOR to COMPANY prior to application. COMPANY reserves the right to have materials tested by an independent laboratory.

- 3.5 Materials shall be stored in sheltered storage in the manufacturer's original packing and away from direct sunlight and in accordance with manufacturer's instructions.

- 3.6 CONTRACTOR shall provide and maintain mobile facilities which contains all necessary equipment and its spares for cleaning repairs, inspection and tests.

- 3.7 CONTRACTOR shall furnish sufficient number of the following equipment and the required spares as a minimum for inspection and purpose for each crew.

- a) Fully automatic full circle adjustable holiday detector with a visible and audible signal system for inspection of coatings.
- b) Thickness gauge for measuring thickness.
- c) Contact type temperature recording thermometer.
- d) Roughness profile measuring (Stylus) instrument.



Laying, Installation, Testing and Commissioning of 8” dia. Steel gas pipeline connectivity in PATAN GA



TENDER DOCUMENT NO
REPL/SGL/STPL/009/22

Date: -06/12/2022

4. APPLICATION PROCEDURE

4.1 General

4.1.1 The application procedure shall be in accordance with manufacturer’s instruction and minimum requirements specified below whichever are most stringent and shall be demonstrated to and approved by the company. Manufacturer’s expert shall supervise the application and shall be available at site upon request during qualification of application procedure and during construction an CONTRACTOR’S cost.

4.1.2 Operators for coating application shall be given necessary instructions and training before start of work, by the CONTRACTOR. To verify and quality the application procedures, all coating applied during the qualification test, shall be removed for destructive shall only utilize those operators who have been approved / prequalified by the field joint coating manufacturer.

4.1.3 Oil, grease, salt shall be removed from steel surface by wiping with rags soaked with suitable solvents such as naphtha or benzene. Kerosene shall not be used for this purpose. Solvent cleaning procedure according to SSPC-SP 1 shall be followed.

4.1.4 Each field joint shall be blast cleaned using a closed cycle blasting unit or open expendable blasting equipment. With the first equipment type, steel or chilled shot and iron grit shall be used and Garnet material with the second one. During blast cleaning the pipe surface temperature shall be simultaneously more than 50 and more than 30 C above ambient Dew Point, while the ambient Relative Humidity shall not be greater than 85 % prior to surface cleaning the surface shall be completely dry. The surface shall be cleaned to a grade SA 2 1/2 in accordance with Swedish standard SIS-055900 with a roughness profile of. 50-70 microns. Surface roughness profile shall be measured using an approved profile comparator in accordance with ISOI 8503-1 and shall be calibrated prior to the start of the work in accordance with ISO: 8503-3 or ISO-8503-4. The blast cleanliness shall be checked on every joint and the roughness profile shall be checked 1 every 10 joints. Dust girt or foreign matter shall be removed from the cleaned surface by an industrial vacuum cleaner. The dust contamination allowed shall be of a rating max 2 as per ISO: 8502-3. The frequency of checking for dust contamination shall be 1 every 10 joints.

Blast cleaned field joint shall be coated within 2-4 hours according to the conditions below:



Laying, Installation, Testing and Commissioning of 8” dia. Steel gas pipeline connectivity in PATAN GA



TENDER DOCUMENT NO
REPL/SGL/STPL/009/22

Date: -06/12/2022

- | | | | |
|---|----------------------------------|---|---------|
| - | Relative Humidity (RH) > 80 % | - | 2 Hours |
| - | Relative Humidity (RH) > 70-80 % | - | 3 Hours |
| - | Relative Humidity (RH) > 80 % | - | 4 Hours |

Pipes delayed beyond this point showing any visible rust stain shall be blast cleaned.

4.1.5 The field joint surface shall be inspected immediately after blast cleaning and any feature of the steel surface such as weld spatter, scabs, laminations or other imperfections considered injurious to the coating integrity made visible during blast cleaning shall be reported to the company representative and on permission from company representative such defects shall be then re-blast cleaned if the defective area is larger than 50 mm in diameter.

4.1.6 The ends of existing pipe protective coating shall be inspected and chamfered. Unbounded portions of the coating shall be removed and then suitably trimmed. Portions where parent coating is removed shall be thoroughly cleaned as specified. The adjacent chamfered areas of the line pipe coating shall be cleaned and abraded, to expose a clean uniform fresh surface of uncontaminated factory applied coating.

4.1.7 All steel joint surfaces shall be thoroughly examined before the application of the coating in order to ensure the surfaces are free of oil, grease, rust, earth or any other foreign matter. All these substances shall be removed coating, to the procedures herein described.

4.1.8 Protection coating shall be applied on the joints immediately after the completion of cleaning operation.

4.2 Application of Heat Shrink Wraparound / Sleeves

In addition to the general requirements stated above, following shall be taken into account.

4.2.1 The wrap around sleeve shall be a size such that a minimum overlap of 50mm before applying is ensured (after shrinking) on both sides of the yard applied corrosion coating of pipes. In the cases where carrier pipe is installed by direct boring/jacking, the overlap on the mill coating for the leading edges of the joints shall be minimum 200mm. When this extra overlap is achieved by providing an additional patch of heat shrink tape/ wraparound it shall be applied in such a manner that the square edge of the patch on the joint coating is in the direction opposite to the direction of boring/ jacking.



Laying, Installation, Testing and Commissioning of 8” dia. Steel gas pipeline connectivity in PATAN GA



TENDER DOCUMENT NO
REPL/SGL/STPL/009/22

Date: -06/12/2022

- 4.2.2** Before centering the wraparound sleeve, the bare steel surface shall be preheated with torch moved back and forth over the surface or by induction heating. The minimum preheat temperature shall be as recommended by manufacturer and shall be checked by means of contact type temperature recording thermometer. Temperature indicating crayons shall not be used pre-heat temperature shall be checked on every joint. Care shall be taken to ensure that the entire circumference of the pipe is heated evenly. Temperature measuring instruments shall be calibrated immediately before the start of the works and thereafter at intervals recommended by the manufacturer of the instrument.
- 4.2.3** Upon pre-heating the pipe surface shall be applied with two pack epoxy primer of wet film thickness 100 microns or as per manufacture’s recommendation whichever is higher, to cover the exposed bare metal of the welded field joint and 10mm min. onto the adjacent pipe coating if recommended by the manufacture. The wet film thickness of the primer shall be checked on every joint with a wet film thickness gauge prior to installation of sleeve. Thickness gauges shall be calibrated once per shift.
- 4.2.4** Immediately after application of epoxy primer, the wraparound sleeve shall be entirely wrapped around the pipe within the stipulated time recommended by the manufacture. Sleeve shall be positioned such that the douser patch is located to one side of the pipe in 10 or 2 O’clock position, with the edge of the undergoing layer facing upward and an overlap of min. 50mm. Gently heat by appropriate torch the backing and the adhesive of the closure and press firmly into place.
- 4.2.5** A heat shrinking procedure shall be applied to shrink the sleeve in such a manner to start shrinkage of the sleeve beginning from the center of the sleeve and heat circumferentially around the pipe. Continue heating from the center towards one end of the sleeve until recovery is completed. In a similar manner, heat and shrink the remaining side. Shrinking has been completed when the adhesive begins to ooze at the sleeve edges allaround the circumference.

The complete shrinking of the entire sleeve shall be obtained without undue heating of existing pipe coating and providing due bonding between pipe, sleeve and pipe coating. The installed sleeve shall not be disturbed until the adhesive has codified.

4.3 Application procedure for corrosion protection Tapes:

- 4.3.1** Cold applied joint protection tapes shall be of the type which can be applied by spirally wrapping on the pipe.
- 4.3.2** Immediately after the completion of surface preparation the approved primer of wet film thickness 100 microns or as per manufacture’s recommendation whichever is higher to cover the exposed bare metal of the welded field joint and 10mm min. onto the adjacent pipe coating if recommended by the manufacture. Any dirt on the primed surface shall be removed. If the primer is damaged, the damaged area shall be cleaned and re-primed.



Laying, Installation, Testing and Commissioning of 8" dia. Steel gas pipeline connectivity in PATAN GA



TENDER DOCUMENT NO
REPL/SGL/STPL/009/22

Date: -06/12/2022

4.3.3 Approximately 100mm of tape interleaving paper shall be peeled back and tape shall be applied with the adhesive side to the pipe. Whilst continuously removing the interleaving paper, the tape shall be spirally applied to provide a minimum of 55% overlap. Sufficient tension shall be applied to ensure good conformity, avoiding air pockets and also continuously smooth out as the wrapping proceeds. The wrapping shall start and finish to give a minimum of 50mm overlap on to the adjoining yard applied coating. Outer wrap shall be applied in similar method.

4.4 Pre-Qualification of Field Joint Coating System

The field joint coating system materials and the procedures proposed by the contractor shall be pre-qualified during the sleeve installation start-up phase. Five joints (5) shall be coated with the requirements of this specification and then inspected and tested in accordance with the requirements of this specification with respect to the following:

- Surface preparation cleanliness, roughness profile and dust contamination.
- Pre-heat temperature (as applicable)
- Primer thickness
- As applied coating thickness
- Holiday detection
- Peel test at (+) 230°C & (+) 60°C on pipe surface & factory applied coating and at over laps (as applicable). If required to achieve the temperature of (+) 60°C, suitable thermal blanket may be used.
- Visual appearance and void after installation on the body, are adjoining the weld and area adjoining the factory applied coating. (To establish voids adjoining the weld and factory coating a strip of 50mm wide and 200mm long shall be stripped and examined.)

Company Representative shall witness the tests and inspection. Regular application of field coating shall commence only upon successful completion of the pre-qualification testing.

After successful completion of the pre-qualification testing as above, the entire field joint coating shall be removed, the pipe surface re-blasted and field joint coating re-applied as per the requirements of this specification.

5. INSPECTION & TESTING

5.1 Visual Inspection

Visual inspection of the as applied coating shall be carried out on every joint, for the following:

- Mastic extrusion on either ends of the sleeve shall be examined.
- There shall be no sign of punctures or pinholes or bend failure. The external appearance of the sleeve shall be smooth, free of dimples, air entrapment or



Laying, Installation, Testing and Commissioning of 8” dia. Steel gas pipeline connectivity in PATAN GA



TENDER DOCUMENT NO
REPL/SGL/STPL/009/22

Date: -06/12/2022

void formation. All sleeves shall be tested for the presence of voids by knocking on the sleeves. A hollow sound compared to the remainder of the sleeve may indicate the presence of voids under the sleeve. Such sleeve shall be tested for adhesion at the discretion of the company representative.

- Weld bead profile shall be visible through the sleeve.
- Visual indicator provided on the backing and the closure patch showing desired heat is achieved.

5.2 Holiday Inspection

The holiday detector used shall be checked and calibrated daily with an accurate DC voltmeter. The detector electrode shall be in direct contact with the surface of coating to be inspected.

The entire surface of the joint section shall be inspected by means of a full circle holiday detector approved by COMPANY set to a DC voltage applicable as per the requirements of factory applied mainline coating specification of company. Inspection of the sleeves shall be conducted only after the joint has cooled below 500 C. The holiday detector used shall be checked and calibrated daily with an accurate DC voltmeter. The detector electrode shall be in direct contact with the surface of coating to be inspected.

No filed joint shall be covered or lowered in the trench until it has been approved by the COMPANY.

5.3 As-applied coating Thickness.

Coating thickness shall be checked by non-destructed methods for each field joint. Average thickness of the as-applied coating on pipe body shall be established based on measurement at min. eight locations i.e. four measurement on either the minimum thickness on the girth weld, four measurement shall be taken on the weld at 3,6,9 & 12 O'clock positions. All such measurements shall be recorded. Company Representative reserves the right to ask for additional measurement at any location on the five joint coating, whenever doubt arises.

5.4 Peel Strength Testing

5.4.1 One out of every 50 joint coatings or joint coating out of every day's production whichever is stringent shall be tested to establish the peel strength on steel and factory applied coating. Contractor shall carry out such testing in the presence of company Representative.

5.4.2 From each test sleeve selected as above, one or more strips of size 25mmx 200mm shall be cut perpendicular to the pipe axis and slowly peeled off. The required peel



Laying, Installation, Testing and Commissioning of 8” dia. Steel gas pipeline connectivity in PATAN GA



TENDER DOCUMENT NO
REPL/SGL/STPL/009/22

Date: -06/12/2022

strength shall meet the requirements of this specification as applicable for (+) 230 C or (+) 600 C whichever is feasible. This test shall be conducted between wrapping & metal and mill coating & between layers at overlap with joint coating (wherever applicable). After removal of strip, the bulk of adhesive shall remain adhered to the pipe showing no bare metal, otherwise, test shall be considered failed. The adhesive layer that remains on the pipe surface shall generally be free of voids resulting from air or gas inclusion. In case the peel strength test at a different temperature than that specified in warranted due to the ambient site conditions, then the peel strength shall comply the recommendation of the manufacturer. Manufacturer shall be asked to furnish peel strength values corresponding to various expected temperatures, prior to start of the works.

- 5.4.3** If the sleeve does not meet the requirements of clause 5.4.2 the adjacent two sleeves shall also be tested. If the adjacent two sleeves are acceptable the test rate shall be increased to one sleeve every twenty-five until company’s representative is satisfied. The test rate can then be reduced as per clause 5.4.1 if either or both of the adjacent two sleeves do not meet the requirements of clause 5.4.2, the field joint shall be stopped.
- 5.4.4** Company representative reserve the right of 100 % removal of sleeves if he is not convinced that the requirements of clause 5.4.2 are achieved.

6. Repairs

- 6.1 If a field joint is detected to be unacceptable after testing as per section 5.0 of this specification the contractor shall, at his own cost:
- Determine the cause of the faulty results of the field coating.
 - Mobilise the expert of manufacturer, if required.
 - Test to be complete satisfaction of the COMPANY, already completed field coatings.
 - Stop field coating until remedial measures are taken against the causes of such faults, to the entire satisfaction of the company.
- 6.2 CONTRACTOR shall replace all joint found or expected to be unacceptable as per section 5.0 of this specification.
- 6.3 CONTRACTOR shall, at his own cost repair all areas where the coating has been removed for testing by COMPANY.
- 6.4 After the coating work on welded joints, fittings and repairs to the coating have been completed the coating as a whole shall be tested with a spark- tester before lowering or jacking the pipeline.



Laying, Installation, Testing and Commissioning of 8” dia. Steel gas pipeline connectivity in PATAN GA



TENDER DOCUMENT NO
REPL/SGL/STPL/009/22

Date: -06/12/2022

6.5 COMPANY shall entitled to check the coating on buried pipelines or parts of pipelines with equipment such as the “Pearson meter” and the resistance meter. If the coating defects are established, the contractor shall be responsible for excavations at such points repair the coating, spark testing and back filling the excavations without extra charge.

7. Documentation

7.1 Prior to procurement of coating materials, contractor shall furnish the following Information for qualification of the manufacturer and material:

- i. complete information as per clause 5.2, DIN EN 12068 along with descriptive technical catalogues.
- ii. Test certificates and result of previously conducted tests, for all properties listed in clause 3.2 of this specification.
- iii. Reference list of previous supplies, in last 5 years, of the similar material temperature, year of supply, project name, contact person and feed back on performance.

Once the Company’s approval has been given, any change in material or manufacturer shall be notified to company, whose approval in writing of all changes shall be obtained before the materials are manufactured.

7.2 Prior to shipment of materials from the manufacturer’s works. Contractor shall furnish the following documents:

- i. Test certificates / result as per manufacturer’s Quality Control procedure for each batch of materials.
- ii. Specific application instructions with pictorial illustrations.
- iii. Specific storage and handling instructions.

7.3 All documents shall be in English language only.



Sabarmati Gas Ltd.

(A Joint Venture of GSPC and BPCL)



SABARMATI GAS LIMITED

**LAYING, INSTALLATION, TESTING AND COMMISSIONING OF 8”
DIA. STEEL GAS PIPELINE CONNECTIVITY IN PATAN GA**

RESONANCE ENERGY PVT. LTD.

**Specification for Repair of Pipeline Corrosion Coating
Tender No. REPL/SGL/STPL/009/21**

0	25/11/2022	Issued for RFP	AS	PG	PC
Rev.	Date	Description	Prepared By	Checked By	Approved By

	LAYING AND CONSTRUCTION OF 8” NB UNDERGROUND STEEL PIPELINE AND ASSOCIATED WORK	
TENDER DOCUMENT NO REPL/SGL/STPL/009/22		Date: -28/11/2022

CONTENTS

1. SCOPE
2. MATERIAL AND EQUIPMENT
3. APPLICATION PROCEDURE
4. INSPECTION / TEST
5. HOLIDAY INSPECTION



LAYING AND CONSTRUCTION OF 8" NB UNDERGROUND STEEL PIPELINE AND ASSOCIATED WORK



TENDER DOCUMENT NO
REPL/SGL/STPL/009/22

Date: -28/11/2022

1.0

SCOPE :

This specification covers the minimum requirement of material and equipment, installation procedure and inspection of repair of damaged polyethylene coatings on steel pipes.

1.1

The repair shall be carried out using repair patch made of radiation cross linked polyolefin backing, coated on the inside with semi – crystalline thermoplastic Adhesive and filler mastic.

2.0

MATERIAL ANDEQUIPMENT

2.1

CONTRACTOR shall supply all, equipment and manpower required for a skillful and adequate application in the field in accordance with the specification.

2.2

The repair material shall be :

- Repair patch shall be cross linked polyolefin with semi – crystalline thermoplastic adhesive (PERP patch make of RAYCHEM or equivalent).
- Filler mastic : PERPFILLER make of RAYCHEM or equivalent.

2.3

The material shall not be older than their period of validity at the time of Application by CONTRACTOR. Deteriorated / decomposed materials shall not be used.

2.4

Material shall be stored in sheltered storages in the manufacture's original packing and away from direct sunlight and in accordance with manufacture's recommendations.

3.0

APPLICATION PROCEDURE

Application procedure shall be as per manufacture's recommendations and as per the following guidelines (ref. Fig : 1)

Preparation : Remove coating from damaged area with knife, scraper or power brush. Scrap off the damaged area and adjacent coating to remove oil, grease, ruse dirt and moisture.

Preheating : Preheat the exposed bare metal surface to about 60 C and adjacent pipe coating to about 47 C with a torch moved backand forth over the surface.



LAYING AND CONSTRUCTION OF 8" NB UNDERGROUND STEEL PIPELINE AND ASSOCIATED WORK



TENDER DOCUMENT NO
REPL/SGL/STPL/009/22

Date: -28/11/2022

Application of the Filler : Plastic filler shall be applied to all exposed metal surface. The mastic is heated and smoothed down with a paint scraper to cover all bare metal in a manner such that all entrapped air is removed.

Application of repair tape : Cut a patch from the tape in a manner such that it extends 50 mm beyond the damaged area, position it over the damaged area heat until the temperature sensitive paint on the outside of the patch changes colour. It shall be smoothed down to conform with the contour of lap, and shall be freed of any air bubbles or wrinkles.

For cosmetic type of defects such as minor gauging tearing scratches which do not indicate holiday during holiday inspection following procedure shall be adopted:

The defect area shall be roughened to remove loose polyethylene coating oil grease, dirt etc.

This shall be followed by application of repair patch as described above

4.0 **INSPECTION. TEST**

A visual inspection shall be carried out for the following

- Mastic extrusion on the patch shall be examined.
- There shall be no sign of punctures or pin holes or bend failure. The external appearance of the patch shall be smooth, free from dimples, air entrapment or void formation.
- The entire repair patch shall have changed colour uniformly.

5.0 **HOLIDAY INSPECTION**

The holiday detector used shall be checked and calibrated easily with an accurate D.C. Voltmeter. The detector electrode shall be in direct contact with the surface of coating to be inspected.

The entire surface of the repaired section shall be inspected by means of a full circle holiday detector approved by company set to a DC Voltage of at least 25 KV. Inspection of repaired patch shall be conducted only after it has cooled below 50 C.



**LAYING AND CONSTRUCTION
OF 8" NB UNDERGROUND STEEL
PIPELINE AND ASSOCIATED
WORK**



**TENDER DOCUMENT NO
REPL/SGL/STPL/009/22**

Date: -28/11/2022

No repaired point shall be covered or lowered in the trench until it has been approved by the COMPANY.



Sabarmati Gas Ltd.

(A Joint Venture of GSPC and BPCL)

SABARMATI GAS LIMITED

**LAYING, INSTALLATION, TESTING AND COMMISSIONING OF 8”
DIA. STEEL GAS PIPELINE CONNECTIVITY IN PATAN GA**

RESONANCE ENERGY PVT. LTD.

**Specification for Shop and Field Painting
Tender No. REPL/SGL/STPL/009/22**

0	25/11/2022	Issued for RFP	AS	PG	PC
Rev.	Date	Description	Prepared By	Checked By	Approved By



**LAYING AND CONSTRUCTION
OF 8" NB UNDERGROUND STEEL
PIPELINE AND ASSOCIATED
WORK**



**TENDER DOCUMENT NO
REPL/SGL/STPL/009/22**

Date: -28/11/2022

CONTENTS

- 1.0 GENERAL
- 2.0 SCOPE
- 3.0 CODES & STANDARDS
- 4.0 EQUIPMENT
- 5.0 SURFACE PREPARATION



LAYING AND CONSTRUCTION OF 8" NB UNDERGROUND STEEL PIPELINE AND ASSOCIATED WORK



TENDER DOCUMENT NO
REPL/SGL/STPL/009/22

Date: -28/11/2022

1. GENERAL

1.1 These technical specifications shall be applicable for the work covered by the contract, and without Prejudice to the various codes of practice, standard specifications etc. It is understood that contractor shall complete the work in all respects with the best quality of materials and workmanship and in accordance with the best engineering practice and instructions of Engineer-in-charge.

1.2 Wherever it is stated in the specification that a specific material is to be supplied or a specific work is to be done, it shall be deemed that the same shall be supplied or carried out by the contractor.
Any deviation for this standard without within deviation permit form appropriate authority will result in rejection to job.

2.0 SCOPE

Scope of work covered in the specification shall include, but not limited to the following.

2.1 This specification defines the requirements for surface preparation selection and application of paint on external surfaces of equipment, vessels, machinery, piping, ducts, steels structures, external & internal protection of storage tanks for all services RCC Chimney & MS Chimney with or without refractory lining and flare lines etc..

2.2 Extent of Works

2.2.1 The following surfaces and materials shall require shop, pre- erection and field painting.

- a) All uninsulated C. S. & A.S. equipment like columns, vessels, drums, storage tanks, heat exchangers, pumps, compressors, electrical panels and motors etc..
- b) All insulated carbon and low alloy piping fittings and valves (including painting of identification marks) furnace ducts and stacks.
- c) All items contained in a package unit as necessary.
- d) All structural steel work, pipe, structural steel supports, walkways, handrails, ladders, platforms etc.
- e) RCC/MS chimneys with or without refractory lining & Flare lines.
- f) Identification color bands on all piping as required including insulated aluminum clad, galvanized, SS and non-ferrous piping.
- g) Identification lettering / numbering on all painted surfaces of equipment /



LAYING AND CONSTRUCTION OF 8" NB UNDERGROUND STEEL PIPELINE AND ASSOCIATED WORK



TENDER DOCUMENT NO
REPL/SGL/STPL/009/22

Date: -28/11/2022

piping insulated aluminum clab, galvanized, SS and non-ferrous piping.

- h) Marking / identification signs on painted surfaces of equipment / piping for hazardous service.
- i) Supply of all primers, paints and all other surfaces of equipment / piping for hazardous service.
- j) Over insulation surface of equipments and pipes wherever required.
- k) Painting under insulation for carbon steel and stainless steel as specified.
- l) Repair work of damaged / pre-erection / fabrication shop primer and weld joints at field.

2.2.2 The following surface and materials shall not be painted unless otherwise specified :

- a) Uninsulated austentic stainless steel.
- b) Plastic and / or plastic coated materials.
- c) Non ferrous materials like minimum, galvanized "Piping" "gratings" and "handrails" etc. except G.I. Towers.

2.3 Documents

2.3.1 The contractor shall perform the work in accordance with the following documents issued to him for executions of work.

- a) Bill of quantities for piping, equipment, machinery and structure etc.
- b) Piping line list.
- c) Painting specifications including special civil deface requirement .

2.4 Unless otherwise instructed final painting on pre-erection / shop primed pipes and equipments shall be painted in the field, only after mechanical completion and testing on system are completed as well as, after completion of steam purging wherever required.

2.5 Changes and deviations required for any specific job due to clients requirement or otherwise shall be referred to REPL for deviation permit.

3.0 CODES & STANDARDS

3.1 Without prejudice to the provision of clause 1.1 above and the detailed specifications of the contract, the following codes and standards shall be followed for the work covered by this contract.



**LAYING AND CONSTRUCTION
OF 8” NB UNDERGROUND STEEL
PIPELINE AND ASSOCIATED
WORK**



TENDER DOCUMENT NO
REPL/SGL/STPL/009/22

Date: -28/11/2022

IS : 5 : Colour coding
 IS-101 : Methods of test for ready mixed paint
 IS-2379:1990 : Indian standard for pipe line Identification – Colour code.
 ASTM : American standard test methods for
 Paints and coatings.
 ASA A 13.1-1981 : Scheme for Identification of piping
 systems : American National Standards
 Institution.

3.2 Surface Preparation Standards :

3.2.1 Swedish Standard : SIS-05 5900-1967 / ISO-8501-1-1998 (Surface preparation standards for painting steel surfaces) This standard contains photographs of the various standards on four different degrees of rusted steel and as such is preferable for inspection purpose by the Engineer-in-Charge.

3.2.2 Steel structure painting Council, U.S.A. (Surface preparations specifications (SSPC-SP).

3.2.3 British standard (Surface finish or Blast – cleaned for painting) BS:4232.

3.2.4 National Associations of Corrosion Engineers, U.S.A. (NACE).

3.2.5 Various International Standards equivalent to Swedish Standard for surface preparation are given in Table-I.

3.3 The contractor shall arrange, at his own cost, to keep a set of latest editions of any one of the above standards and codes at site.

3.4 The paint manufacturer’s instructions shall be followed as far as practicable at all times. Particular attention shall be paid to the following:

- a) Instructions for storage to avoid exposure as well as extremes of temperature.
- b) Surface preparations prior to painting.
- c) Mixing and thinning.
- d) Application of paints and the recommended limit on time intervals between coats.

4.0 EQUIPMENT

4.1 All tools, brushes, rollers, spray guns, abrasive materials hand/power tools for leaning and all equipments, scaffolding materials, shot / wet abrasive blasting, water blasting equipments & air compressors etc. required to be used shall be suitable for the work and all in good order and shall be arranged by the contractor at site and in sufficient quantity.

4.2 Mechanical mixing shall be used for paint mixing operations in case of two



**LAYING AND CONSTRUCTION
OF 8” NB UNDERGROUND STEEL
PIPELINE AND ASSOCIATED
WORK**



TENDER DOCUMENT NO
REPL/SGL/STPL/009/22

Date: -28/11/2022

pack systems except that the Engineer-in-Charge may allow the hand mixing of small quantities at his discretion.

5.0 SURFACE PREPARATION, SHOP COAT, COATING APPLICATION & REPAIR AND DOCUMENTATION.

5.1 General

5.1.1 In order to achieve the maximum durability, one or more of following methods of surface preparation shall be followed, depending on condition of steel surface and as instructed by Engineer-in-charge. Adhesion of the paint film to surface depends largely on the degree of cleanliness of the metal surface. Proper surface preparation contributes more to the success of the paint protective system.

- a) Manual or hand tools cleaning.
- b) Mechanical or power tool cleaning
- c) Blast cleaning.

5.1.2 Mill scale, rust, rust scale and foreign matter shall be removed fully to ensure that a clean and dry surface is obtained. The minimum acceptable standard in case of manual or hand tool cleaning shall be St. 2 or equivalent, in case of mechanical or power tool cleaning it shall be St. 3 or equivalent, in case of blast cleaning it shall be Sa 2 1/2 or equivalent as per Swedish Standard SIS-055900-1967/ISO-8501-1-1988. Where highly corrosive condition exists, then blast cleaning shall be Sa3 as per Swedish Standard.

Remove all other contaminates, oil, grease etc. by use of anaromatic solvent prior to surface cleaning.

5.1.3 Blast cleaning shall not be performed where dust can contaminate surfaces undergoing such cleaning or during humid weather conditions having humidity exceeding 85%.

5.1.4 Irrespective of the method of surface preparation, the first coat of primer must be applied on dry surface. This should be done immediately and in any case within 4 hours of cleaning of surface. However, at times of unfavorable weather conditions, the Engineer- in-Charge shall have the liberty to control the time period, at his sole discretion and / or to insist on recleaning, as may be required, before primer application is taken up. In general, during unfavorable weather conditions, blasting and painting shall be avoided as far as practicable.

5.1.5 The external surface of R.C.C. chimney to be painted shall be dry and clean. Any loose particle of sand, cement, aggregate etc. shall be removed by scrubbing with soft wire brush if necessary, acid etching with 10-15% HCL solution for about 15 minutes shall be carried out and surface must be



**LAYING AND CONSTRUCTION
OF 8” NB UNDERGROUND STEEL
PIPELINE AND ASSOCIATED
WORK**



TENDER DOCUMENT NO
REPL/SGL/STPL/009/22

Date: -28/11/2022

thorough washed with water to remove acid & loose particles then dry completely before application of paint.

5.2 Procedure of Surface Preparation

5.2.1 Blast Cleaning

5.2.1.1 Air Blast Cleaning

5.2.1.2 The surface shall be blast cleaned using one of the abrasives : AL₂O₂ particles chilled casts iron or malleable iron and steel at pressure of 7Kg/Cm² at appropriate distance and angle depending on nozzle size maintaining constant velocity and pressure. Chilled cast iron, malleable iron and steel shall be in the form of shot or grit of size not greater than 0.055” maximum in case of steel and malleable iron and 0.04” maximum in case of chilled iron. Compressed air shall be free from moisture and oil. The blasting nozzles should be venture style with tungsten carbide or boron carbide as the materials for liners. Nozzles orifice may vary from 3/16” to 3/4”. On completion of blasting operation, the blaster surface shall be clean and free from any scale or rust and must show a grey white metallic lusture. Primer or first coat of paint shall be applied within 4 hours of surface preparation. Blast cleaning shall not be done outdoors in bad weather without adequate protection or when there is dew on the metal which is to be cleaned surface profile shall be uniform to provide good key to the paint adhesion (i.e.35 to 50p) If possible vacuum collector shall be installed for collecting the abrasive and recycling.

5.2.1.3 Water Blast cleaning

Environmental, health and safely problems associate with abrasive blast cleaning limit the application of air blast cleaning in many installations. In such case water blast cleaning is resorted to.

Water blast cleaning can be applied with or without abrasive and high pressure water blasting. The water used shall be inhibited with sodium chromate/ phosphate. The blast cleaned surface shall be washed thoroughly with detergents and wiped with solvent and dried with commonly use pressure for high pressure water balst. Cleaning for maintenance surface preparation is 3000 to 6000 psi at 35-45 liters/ minute water volume and pressure upto 10000 psl and water volume of 45 liters/ minute provide maximum cleaning.

The water blast cleaned surface shall be comparable to SSPC-SP- 12/NACE No. 5. The operation shall be carried out as per SSPC guidelines for water blast cleaning. The indicative values for sand injection is.

Air	:	300 to 400 Cu.ft/min.
Water	:	6-5-10 liter/min. with corrosion inhibitor
Sand	:	200-400 lbs/ hr.
Nozzle	:	0.5 to 1” dia.



LAYING AND CONSTRUCTION OF 8" NB UNDERGROUND STEEL PIPELINE AND ASSOCIATED WORK



TENDER DOCUMENT NO
REPL/SGL/STPL/009/22

Date: -28/11/2022

Special equipments for water blast cleaning with abrasives now available shall be used.

5.2.2 Mechanical of Power tool cleaning.

Power tool cleaning shall be done by mechanical striking tools, chipping hammers, grinding wheels or rotating steel wire-brushes. Excessive burnish of surface shall be avoided as it can reduce paint adhesion. On completion of cleaning, the detached rust mill scale etc. shall be removed by clean rags and/or washed by water or steam and thoroughly dried with compressed air jet before application of paint.

5.2.3 Manual or hand tool cleaning.

Manual or hand tool cleaning is used only where safety problems limit the application of other surface preparation procedure and hence does not appear in the specifications of paint systems.

Hand tool cleaning normally consists of the following :

- a. Hand descaling and/or hammering
- b. Hand scraping
- c. Hand wire brushing.



Rust, mill scale spatters, old coating and other foreign matter, shall be removed by hammering, scrapping tools, emery paper cleaning, wire brushing or combination of the above methods. On completion of cleaning, loose materials shall be removed from the surface by clean rags and the surface shall be brushed, swept, dedusted and blown off with compressed air/steam to remove all loose matter. Finally the surface may be washed with water and dried for effective cleaning.

5.3 Non compatible shop coat primer.

The compatibility of finishing coat should be confirmed from the paint manufacturer. In the event of use of primer such as zinc rich epoxy, inorganic zinc silicate etc. as shop coat, the paint system shall depend on condition of shop coat. If shop coat is in satisfactory condition showing no major defects, the shop coat shall not be removed. The touch up primer and finishing coat(s) shall be identified for application by Engineer-in Charge.

5.4 Shop coated (coated with primer & finishing coat) equipment should not be repainted unless paint is damaged.

5.5 Shop primed equipment and surface will only be „spot cleaned“ in damaged areas by means of power tool brush cleaning and then spot primed before applying one coat of field primer unless otherwise specified. If shop primer is not compatible with field primer then shop coated primer should be completely removed before application of selected paint system for particular environment.

	LAYING AND CONSTRUCTION OF 8” NB UNDERGROUND STEEL PIPELINE AND ASSOCIATED WORK	
TENDER DOCUMENT NO REPL/SGL/STPL/009/22		Date: -28/11/2022

5.6 For packaged units/ equipment, shop primer should be as per the paint system given in this specification. However, manufacturer’s standard can be followed after review.

5.7 Coating Procedure and Application :

5.7.1 Surface shall not be coated in rain, wind or in environment where injurious airborne elements exists, when the steel surface temperature is less than 5 F above dew point when the relative humidity is greater then 85% or when the temperature is below 40 F.

5.7.2 Blast cleaned surface shall be coated with one complete application of primer as soon as practicable but in no case later than 4 hrs. the same day.

5.7.3 To the maximum extent practicable, each coat of material shall be applied as a continuous film uniform thickness free of probes. Any sport or areas missed in application shall be recoated and permitted to dry before the next coat is applied. Applied paint should have the desired wet film thickness.

5.7.4 Each coat shall be in proper state of cure or dryness before the application of succeeding coat. Material shall be considered dry for recoating when an additional coat can be applied without the development of any detrimental film irregularities such as lifting or loose of adhesion of the under coat. Manufacturer instruction shall be followed for Interco at interval.

5.7.5 When the successive coat of the same colour have been specified, alternate coat shall be tinted, when practical, sufficiently to produce enough contrast to indicate complete coverage of the surface. The tinting material shall be compatible with the material and not detrimental to its service life.

5.7.6 Air spray application shall be in accordance with the following :

- a) The equipment used shall be suitable for the intended purpose shall be capable of property atomizing the paint to be applied, and shall be equipped with suitable pressure regulators and gauges, The air caps, nozzles, and needles shall be those recommended by the manufacturer of the equipment for the material being sprayed. The equipment shall be kept in satisfactory condition to perm proper paint application.
- b) Traps or separators shall be provided to remove oil and condensed water from the air. These traps or separators must be for adequate size and must be drained periodically during operations. The air from the spray gun impinging against the surface shall show no condensed water or oil.
- c) **Ingradients shall be kept properly mixed in the spray pots or containers during application by continuous mechanical agitation.**



**LAYING AND CONSTRUCTION
OF 8" NB UNDERGROUND STEEL
PIPELINE AND ASSOCIATED
WORK**



TENDER DOCUMENT NO
REPL/SGL/STPL/009/22

Date: -28/11/2022

- d) The pressure on the material in the pot and of the air at the gun shall be adjusted for optimum spraying effectiveness. The pressure on the material in the pot shall be adjusted when necessary for change in elevation of the gun above the pot. The atomizing air pressure at the gun shall be high enough to properly atomize the paint but not so high as to cause excessive fogging of paint, excessive evaporation of solvent, or less by over spray.
- e) Spray equipment shall be kept sufficiently clean so that dirt, dried paint, and other foreign materials are not deposited in the paint film. Any solvents left in the equipment shall be completely removed before applying paint to the surface being painted.
- f) Paint shall be applied in a uniform layer, with overlapping at the edge of the spray pattern. The spray patterns shall be adjusted so that the paint is deposited uniformly. During application the gun shall be held perpendicular to the surface and at a distance, which will ensure that a wet layer of paint is deposited on the surface. The trigger of the gun should be released at the end of each stroke.
- g) All runs and sags shall be brushed out immediately or the paint shall be removed and the surface repainted.
- h) Areas inaccessible to the spray gun shall be painted by brush: if not accessible by brush, daubers or sheepskins shall be used.
- i) All nameplates, manufacturer's identification tags, machined surface instrument glass, finished flange faces, control valve items and similar items shall be masked to prohibit coating disposition. If these surfaces are coated, the component shall be cleaned and restored to its original condition.
- j) Edges of structural shapes and irregular coated surface shall be coated first and an extra pass made later.
- k) If spray gun shown choking, immediately decoking procedure shall be followed.

5.7.7

Airless spray application shall be in accordance with the following procedure: as per steel structure paint manual vol. 1 & vol. 2. By SSPC, U.S.A. Air less sprays relief on hydraulic pressure rather than air atomization to produce the desired spray. An air compressor or electric motor is used to operate a pump to produce pressures of 1,000 to 6,000 psi. Paint is delivered to the spray gun at this pressure through a single hose within the gun; a single paint stream is divided into separate streams, which are forced through a small orifice resulting in atomization of paint without the use of air. This results in more repaid coverage with less over spray. Airless spray usually is faster, cleaner, more economical and easier to use



LAYING AND CONSTRUCTION OF 8" NB UNDERGROUND STEEL PIPELINE AND ASSOCIATED WORK



TENDER DOCUMENT NO
REPL/SGL/STPL/009/22

Date: -28/11/2022

than conventional air spray.

- 5.7.8 Brush application of paint shall be in accordance with the following:
- Brushed shall be of a style and quality that will enable proper application of paint.
 - Round or oval brushes are most suitable for rivets, bolts, irregular surfaces and rough or pitted steel. Wide flat brushes are suitable for large flat areas, but they shall not have width over five inches.
 - Paints shall be applied into all corners.
 - Any runs or sags shall be brushed out.
 - There shall be minimum of brush marks left in the applied paint.
 - Surfaces not accessible to brushes shall be painted by spray, daubers, or sheepkin.

5.7.9 Manual application by sling (where 6 O" clock position of pipe is not approachable).

5.7.10 For each coat the painter should know the WFT corresponding to the specified DFT and standardize the paint application technique to achieve the desired WFT. This is to be ensured in the qualification trial.

5.8 Drying of Coated Surfaces

5.8.1 No coat shall be applied until the preceding coat has dried. The material shall be considered dry for re-coating when another coat can be applied without the development of any film irregularities such as lifting or loss of adhesion of undercoats. Drying time of the applied coat should not exceed maximum specified for its as first coat; if it exceeds the paint material has possibly deteriorated or mixing is faulty.

5.8.2 No paint shall be force dried under conditions, which will cause checking, wrinkling, blistering formation of pores, or detrimentally after the condition of the paint.

5.8.3 No drier shall be added to a paint on the job unless specifically called for in the manufacturer's specification for the paint.

5.8.4 Paint shall be protected from rain, condensation, contamination snow, and freezing until dry to the fullest extent practicable.

5.9 Repair of damaged paint surface

5.9.1 Where paint has been damaged in handling and in transportation, the repair of damaged coating of pre-erection / fabrication shall be as given below.

5.9.2 Repair of damaged inorganic zinc silicate primer after erection / welding:



LAYING AND CONSTRUCTION OF 8" NB UNDERGROUND STEEL PIPELINE AND ASSOCIATED WORK



TENDER DOCUMENT NO
REPL/SGL/STPL/009/22

Date: -28/11/2022

Quickly remove the primer from damaged area by mechanical scraping and emery paper to expose the white metal. Blasts clean the surface if possible. Feather the primer over the intact adjacent surface surrounding the damaged area by emery paper.

5.9.3 Repair of damaged pre-erection and shop priming in the design temperature of – 90 C to 500 C.

- Surface preparation shall be done as per procedure 5.9.2
- One coat of F-9 shall be applied wherever damaged was observed on pre-erection / pre-fabrication / shop primer of inorganic zinc silicate coating (F-9). (F-9) shall not be applied if damaged area is not more than 5 x 5 cm.

5.10 Paint Application

- 5.10.1 Shop priming / pre-erection priming with F9 of F12 shall be done only on blasted surface.
- 5.10.2 Shop priming / pre-erection priming with F-9 or F-12 shall be done only with airless spray.
- 5.10.3 For large flat surface field painting shall be done by airless spray otherwise brush can be used.

5.11 Documentation

1. A written quality plan with procedure for qualification trials and for the actual work.
2. Daily progress report with details of weather conditions, particular of applications, no. of coats and type of materials applied, anomalies, progress of work versus programme.
3. Result of measurement of temperatures relative humidity, surface profile, film thickness, holiday detection adhesion tests with signature of appropriate authority.
4. particular of surface preparation and paint application during trials and during the work.
5. Details of non-compliance, rejects and repairs.
6. Type of testing equipments and calibration.
7. Code and batch numbers of paint material used.



Sabarmati Gas Ltd.
(A Joint Venture of GSPC and BPCL)



SABARMATI GAS LIMITED

**LAYING, INSTALLATION, TESTING AND COMMISSIONING OF 8”
DIA. STEEL GAS PIPELINE CONNECTIVITY IN PATAN GA**

RESONANCE ENERGY PVT. LTD.

**Health, Safety and Environment Management (HSE)
Tender No. REPL/SGL/STPL/009/22**

0	25/11/2022	Issued for RFP	AS	PG	PC
Rev.	Date	Description	Prepared By	Checked By	Approved By



	LAYING AND CONSTRUCTION OF 8” NB UNDERGROUND STEEL PIPELINE AND ASSOCIATED WORK	
TENDER DOCUMENT NO REPL/SGL/STPL/009/22		Date: -28/11/2022

CONTENTS

- 1.0 SCOPE
- 2.0 REFERENCE DOCUMENTS
- 3.0 HEALTH, SAFETY AND ENVIROMENT (HSE) REQUIREMENTS
- 4.0 DETAILS OF HSE MANAGEMENT SYSTEM BY CONTRACTOR

ANNEXURES

- 1 ANNEX-A-RELEVANT I.S. CODE
2. ANNEX-B-REPORTING FORMATS – 5 NOS.
3. ANNEX-C-DO“S DON“T“S ABOUT SAFETY ASPECTS AS
PER FACTORIES ACT

	LAYING AND CONSTRUCTION OF 8” NB UNDERGROUND STEEL PIPELINE AND ASSOCIATED WORK	
TENDER DOCUMENT NO REPL/SGL/STPL/009/22		Date: -28/11/2022

1.0 **SCOPE**

This specification establishes the Healthy, Safety and Environment (HSE) management requirement to be complied with by the Contractors during construction.

Requirement stipulated in this specification shall supplement the requirement of HSE management given in relevant Act (s) / legislations. General Condition of Contract (GCC) Special Condition of Contract (SCC) and Job Specifications. Where different documents stipulate different requirements, the most stringent shall be adopted.

2.0 **REFERENCES**

This document should be read in conjunction with following :

- General Conditions of Contract (GCC)
- Special Conditions of Contract (SCC)
- Job Specification
- Relevant IS Codes (refer Annexure-A)
- Reporting Formats (refer Annexure-B)

3.0 **REQUIREMENT OF HEALTH, SAFETY & ENVIRONMENT (HSE) MANAGEMENT SYSTEM TO BE COMPLETED BY BIDDERS.**

3.1 **Management Responsibility**

3.1.1 The Contract Should have a document HSE policy to cover commitment of the organization to ensure health, safety and environment aspects in their line of operations.

3.1.2 The HSE management system of the Contractor shall cover HSE requirement including but not limited to what specified under clause 1.0 & 2.0 mentioned above.

3.1.3 Contractor shall be fully responsible for planning and implementing HSE requirement to the satisfaction of the company. Contractor as a minimum requirement shall designate / deploy the following to co- ordinate the above :

No. of workers deployed
Up to 250 -

Designate one safety supervisor who will guide the workers from time to time, as well as impart training, basic guidelines at least weakly once.

Above 250 & upto 500

Deploy one qualified and experienced safety Engineer / Officer who will guide the workers from time to time as well as impart basic



**LAYING AND CONSTRUCTION
OF 8” NB UNDERGROUND STEEL
PIPELINE AND ASSOCIATED
WORK**



TENDER DOCUMENT NO
REPL/SGL/STPL/009/22

Date: -28/11/2022

guideline & training at least Weekly
once.

Above 500 (for every 500 or less) One additional safety engineer/
Officer whose function will be as
mentioned above.

Contractor shall indemnify and hold harmless SGL & their representative's
from any and all liabilities arising out of non fulfillment of HSE
requirements.

- 3.1.4 The Contractor shall promote and develop consciousness for Healthy,
Safety and Environment among all personnel working for the Contractor.
Regular awareness programs and fabrication shop/work site meeting shall
be arranged on HSE activities to cover hazards involved in various
operations during construction.
- 3.1.5 The Contractor shall ensure that the Health, Safety and Environment
(HSE) requirements are clearly understood & faithfully implemented at all
levels, at each and every site / work place.
- 3.1.6 Arrange suitable first aid measure such as First Aid Box, trained personnel
to give First Aid, Stand by Ambulance or Vehicle and install fire protection
measures such as: adequate number of steel buckets with sand and water
and adequate fire extinguishers to the satisfaction of SGL.
- 3.1.7 The Contractor shall evolve a comprehensive planned and documented
system for implementation and monitoring of the HSE requirements. This
shall submitted to SGL for approval well in advance, prior to start work.
The monitoring for implementation shall be done by regular inspection and
compliance to the observations thereof. The Contractor work site / Office.
However, compliance of HSE requirement shall be the sole responsibility
of the Contractor. Any review / approval by SGL shall not absolve the
Contractor of his responsibility / liability in relation to all HSE
requirements.
- 3.1.8 Non-Conformance on HSE by the Contractor (including his Sub-
contractors) as brought out during review / audit by SGL representative
shall be resolved forthwith by Contractor, Compliance report shall be
possibility submitted to SGL at the earliest.
- 3.1.9 The Contractor shall ensure participation of his Resident Engineer/ Site-in –
Charge in the Safety Committee/HSE Committee meetings arranged by
SGL. The compliance of any observation shall be arranged urgently.
Contractor shall assist SGL to achieve the targets set by them on HSE
during the project implementation.
- 3.1.10 The Contractor shall adhere consistently to all provisions of HSE



LAYING AND CONSTRUCTION OF 8" NB UNDERGROUND STEEL PIPELINE AND ASSOCIATED WORK



TENDER DOCUMENT NO
REPL/SGL/STPL/009/22

Date: -28/11/2022

requirements. In case of non-compliance or continuous failure in implementation of any of HSE provisions; SGL may impose stoppage of work without any Cost & time implication to Owner and/or impose a suitable memo wise penalty, upto a cumulative limit of 1.0% (one percent) of Contract value with a ceiling of Rs. 10 Lakhs. This penalty shall be in addition to all other penalties specified else where in the contract. The decision of imposing stoppage of work, its extent & monetary penalty shall rest with SGL & binding on the Contractor.

- 3.1.11 All fatal accidents and other personnel accidents shall be investigated by a team of Contractor's senior personnel for root cause and recommend corrective and preventive actions. Findings shall document and suitable actions taken to avoid recurrences shall be communicated to SGL. SGL shall have the liberty to independently investigate such occurrence and Contractor shall extend all necessary help and co-operation in this regard.

3.2 House Keeping

- 3.2.1 Contractor shall ensure that a high degree of house keeping is maintained and shall ensure the followings :

- a) All surplus earth and debris are removed / disposed off from the working site to identified location (s)
- b) Unused / Surplus Cables Steel items and steel scrap LAYING scattered at different places within the working areas are removed to identified location (s).
- c) All wooden scrap, empty wooden cable drums and other combustible packing materials shall be removed from work place to identified location(s).
- d) Roads shall be kept clear and materials like pipes, steel, sand, boulders, concrete chips and bricks, etc. shall not be allowed in the roads to obstruct free movement of men & machineries.
- e) Fabricated steel structural's, pipes & piping materials shall be stacked properly for erection.
- f) Water logging on road shall not be allowed.
- g) No parking of trucks / trolleys, cranes and trailers etc. shall be allowed on of roads, which may obstruct the traffic movements.
- h) Utmost care shall be taken to ensure over all cleanliness and proper up keep of the working areas.
- i) Trucks carrying sand, earth and pulverized materials etc. shall be covered while moving within the plant areas.

3.3 Healthy, Safety and Environment

- a) The Contractor shall provide safe means of access to any working place including provision of suitable and sufficient scaffolding at various stages during all operations of the work for the safety of his workmen, and SGL. Contractor shall ensure deployment of



**LAYING AND CONSTRUCTION
OF 8” NB UNDERGROUND STEEL
PIPELINE AND ASSOCIATED
WORK**



**TENDER DOCUMENT NO
REPL/SGL/STPL/009/22**

Date: -28/11/2022

- appropriate equipment and appliances for adequate safety and healthy of the workmen and protection of surrounding areas.
- b) The Contractor shall ensure that all their staff workers including their sub-Contractor (s) shall wear Safety Helmet and Safety shoes. Contractor shall also ensure use of safety belt, protective goggles, gloves etc. by the personnel as per jobs requirements. All these gadgets shall conform too relevant IS specification equivalent.
 - c) Contractor shall ensure that a proper Safety Net System shall be used at appropriate locations. The safety net shall be located not more than 30 feet (9.0 metrs) below the working surface at site to arrest or to reduce the consequences of possible fall of persons working at different heights.
 - d) Contractor shall ensure that flash back arrester shall used while using gas Cylinders at site. Cylinders shall be mounted on trollys.
 - e) The Contractor shall assign to his workmen, tasks commensurate with their qualification, experience and state of health for driving of vehicles, handing and erections of materials and equipment’s. All lifting equipments shall be tested certified for its capacity before use. Adequate and suitable lighting at every work place and approach there to shall be provided by the contractor before starting the actual work / operation at night.
 - f) Hazardous and / or toxic material such as solvent coating or thinners shall be stored in appropriate containers.
 - g) All hazardous materials shall be labeled with the name of the materials, the hazards associated with its use and necessary precautions to be taken.
 - h) Contractor shall ensure that during the performance of the work all hazards to the health of personnel have been identified assessed and eliminated.
 - i) Chemical spills shall be contained & cleaned up immediately to prevent further contamination.
 - j) All personnel exposed to physical agents such as ionizing or non-ionizing radiation ultraviolet rays or similar other physical agents shall be provided with adequate shielding or protection commensurate with type of exposure involved.
 - k) Where contract or exposure of hazardous materials could exceed limits or could otherwise have harmful affects, appropriate personal protective equipment’s such as gloves, goggles, aprons, chemical resistant clothing and respirator shall be used.



LAYING AND CONSTRUCTION OF 8” NB UNDERGROUND STEEL PIPELINE AND ASSOCIATED WORK



TENDER DOCUMENT NO
REPL/SGL/STPL/009/22

Date: -28/11/2022

- l) Contractor shall ensure the following facilities at work sites :
 - I) A Crèche where 10 or more female workers are having children below the age of 6 years.
 - II) Reasonable Canteen facilities are made available at appropriate location depending up on site conditions.
- m) Suitable facilities for toilet, drinking water, proper lighting shall be provided at site and labor camps, commensurate with applicable Laws/ Legislation.
- n) Contractor shall ensure storage and utilization methodology of material that are not detrimental to the environment. Wherever required Contractor shall ensure that only the environment friendly material are selected.
- o) All person deployed at site shall be knowledgeable for and comply with the environmental laws, rules & regulation relating to the hazardous materials substance and wastes. Contractor shall not dump, release or otherwise discharge or dispose off any such materials without the authorization of SGL.

4.0 **DETAILS OF HSE MANAGEMENT SYSTEM BY CONTRACTOR**

4.1 **On Awards of Contract.**

The Contractor shall prior to start of work submit his Health, Safety and Environment Manual of procedure and HSE Plans for Approval by SGL. The Contractor shall participate in the pre-start meeting with SGL to finalize HSE plans including the following.

- Job procedure to be followed by Contractor for activities covering Handling of equipment's Scaffolding, Electric Installation, Describing the risks involved, actions to be taken and methodology for monitoring each.
- Organizations structure along with responsibility and authority records / reports etc. on HSE activities.

4.2 **During job execution**

4.2.1 Implement approved Health, Safety and Environment management procedure including but not limited to as brought out under para 3.0 Contractor shall also ensure to:

- Arrange workmen compensation insurance, registration under ESI Act, third party liability insurance etc. as applicable.





**LAYING AND CONSTRUCTION
OF 8” NB UNDERGROUND STEEL
PIPELINE AND ASSOCIATED
WORK**



**TENDER DOCUMENT NO
REPL/SGL/STPL/009/22**

Date: -28/11/2022

- Arrange all HSE permits before start of activities (as applicable) like hot work, confined space, work at heights, storage of Chemicals/ explosives materials and its used and implement all precautions mentioned therein.
- Submit timely the completed check list on HSE activities, Monthly HSE report, accident report, investigation report, etc. as per SGL only in case of his absence from site, a second senior most person shall be nominated by him in advance and communicated to SGL.
- Display at site office and work locations caution boards, list of hospitals for emergency services available.
- Provided posters, banners, for safe working to promote safety consciousness.
- Carryout audits / inspection at sub Contractor work as per approved HSE documents & submit the reports for SGL review.
- Assist in HSW audits by SGL and submit compliance report.
- Generate & submit HSE records / reports as per HSE Plan.
- Appraise SGL on HSE activities at site.

	LAYING AND CONSTRUCTION OF 8” NB UNDERGROUND STEEL PIPELINE AND ASSOCIATED WORK	
TENDER DOCUMENT NO REPL/SGL/STPL/009/22		Date: -28/11/2022

ANNEXURE-A

RELEVANT IS – CODES FOR PERSONNEL PROTECTION

IS : 2925 – 1984	:	Industrial Safety Helmets.
IS : 4770 – 1968	:	Rubber gloves for electrical purposes
IS : 6994-1973 (Part-I)	:	Industrial Safety Gloves (Leather & Cotton)IS :
1989-1986 (Part-I & III) :	:	Leather safety boots and shoes.
IS : 3738-1975	:	Rubber knee boots
IS : 5557-1969	:	Industrial and Safety rubber knee boots.
IS : 6519-1971	:	Code of practice for selection, care and repair of Safety footwear
IS:11226-1985	:	Leather Safety footwear having direct moulding sole.
IS:5983-1978	:	Eye protectors.
IS: 9167 – 1979	:	Ear protectors.
IS : 3521-1983	:	Industrial Safety belts and harness.



**LAYING AND CONSTRUCTION
OF 8" NB UNDERGROUND STEEL
PIPELINE AND ASSOCIATED
WORK**



TENDER DOCUMENT NO
REPL/SGL/STPL/009/22

Date: -28/11/2022

**2 MONTHLY CHECKLIST CUM COMPLIANCE REPORT REGARDING
HSE (1/6)**

Project : Contractor

Date : Owner

Inspection by :

Note : Write „NC“ (Not Concern) wherever any of the items are not applicable.

Item	Yes	No	Remark	Action
HOUSEKEEPING				
Waste containers provided and used				
Sanitary facilities adequate and Clean				
Passageways and Walkways Clear				
General neatness of working areas				
Proper Material Storage				
Wooden Boards properly stacked & nails removed				
Cords, leads out of walk and traffic ways				
Scraps removed from the work site				
Other				
PERSONNEL PROTECTIVE EQUIPMENT				
Doggles : Shields				
Face protection				
Hearing protection				
Safety Shoes provided				
Hand protection				
Respiratory Masks etc.				
Safety Belts				
Safety Helmets				
Other				
EXCAVATIONS / OPENINGS				
Excavation permit				
Excavated earth kept away from edge				
Dewatering pump kept away from edge				
Safe access into excavated area				
Openings properly covered or barricaded				
Excavations shored				
Excavations barricaded				
Overnight lighting provided				
Other				



**LAYING AND CONSTRUCTION
OF 8" NB UNDERGROUND STEEL
PIPELINE AND ASSOCIATED
WORK**



TENDER DOCUMENT NO
REPL/SGL/STPL/009/22

Date: -28/11/2022

MONTHLY CHECKLIST CUM COMPLIANCE REPORT REGARDING HSE
(2/6)

WELDING/CUTTING				
Valid hot work permit				
Flashback arrester provided for cylinders				
Power cable not crossing the welding cable				
Adequate ear thing provided				
No combustible materials kept near welding & cutting works.				
Gas cylinder chained upright & kept in trolleys				
Cables and hoses not obstructing				
Screens or shields used				
Flammable materials protected				
Fire extinguisher(s) accessible				
Other				
SCAFFOLDING				
Fully decked platform				
Guard and intermediate rails in place				
Toe boards in place & tied properly				
Adequate shoring				
Adequate access				
Other				
LADDERS				
Extension side rails 1 m above				
Top of landing				
Properly secured at top & bottom				
Angle + 70° from horizontal				
Other				



**LAYING AND CONSTRUCTION
OF 8” NB UNDERGROUND STEEL
PIPELINE AND ASSOCIATED
WORK**



TENDER DOCUMENT NO
REPL/SGL/STPL/009/22

Date: -28/11/2022

MONTHLY CHECKLIST CUM COMPLIANCE REPORT REGARDING HSE
(3/6)

Item	Yes	No	Remark	Action
HOISTS, CRANES AND DERRICKS				
Condition of cables and sheaves OK				
Condition of slings, chains, hooks and eyes OK				
Inspection and maintenance logs maintained				
Outinggers used				
Singh/barricades provided				
Signals observed and understood				
Qulified opretors				
Other				
MACHINERY, TOOLS AND EQUIPMENT				
Proper instruction T				
Saftey devices				
Proper cords				
Inspections and maintenance				
Other				
VEHICLE AND TRAFFIC				
Rules and regulations observed				
Inspection and mantinance				
Licensed drivers				
Other				



**LAYING AND CONSTRUCTION
OF 8" NB UNDERGROUND STEEL
PIPELINE AND ASSOCIATED
WORK**



TENDER DOCUMENT NO
REPL/SGL/STPL/009/22

Date: -28/11/2022

MONTHLY CHECKLIST CUM COMPLIANCE REPORT REGARDING HSE
(4/6)

Item	Yes	No	Remark	Action
TEMPORARY FACILITIES				
Emergency instruction posted				
Fire extinguishers provided				
Fire-aid equipment				
Secured against storm damage				
General nemeses				
In accordance with electrical requirements				
Other				
FIRE PREVENTION				
Personnel instructed				
Fire extinguishers checked				
No smoking in prohibited areas				
Hydrants clear				
Other				
ELECTRICAL				
Proper wiring & earthing				
ELCB's provided				
Ground fault circuit interrupters				
Protection against damage				
Prevention of tripping hazards				
Proper electrical cable joints				
Light poles secured				
Clear way to power distribution board				
Proper rating of fuses				



**LAYING AND CONSTRUCTION
OF 8" NB UNDERGROUND STEEL
PIPELINE AND ASSOCIATED
WORK**



TENDER DOCUMENT NO
REPL/SGL/STPL/009/22

Date: -28/11/2022

**MONTHLY CHECKLIST CUM COMPLIANCE REPORT REGARDING HSE
(5/6)**

Item	Yes	No	Remark	Action
HANDLING AND STORAGE OF MATERIALS				
Properly stored or stacked				
Passageways clear				
Other				
FLAMMABLE GASES AND LIQUIDS				
Containers clearly identified				
Proper storage				
Fire extinguish HSE rs nearby				
Other				
Erection plan				
Safety nets				
Safety belts tied properly				
Illumination				
No loose material at height				
No body under working area				
All openings covered				
Other				
ENVIRONMENT				
Chemical and other Effluents properly disposed				
Cleaning liquid of pipes disposed off properly				
Seawater used for hydro testing disposed off as per agreed proceeding				
Lubricant Waste/Engine oils properly disposed.				
Waste from Canteen office, sanitation etc. disposed properly				
Disposal of surplus earth, stripping materials, Oily rags and combustible materials done properly.				
Screen belt protection				



**LAYING AND CONSTRUCTION
OF 8" NB UNDERGROUND STEEL
PIPELINE AND ASSOCIATED
WORK**



TENDER DOCUMENT NO
REPL/SGL/STPL/009/22

Date: -28/11/2022

MONTHLY CHECKLIST CUM COMPLIANCE REPORT
REGARDING HSE (Conted... 6/6)

Item	Yes	No	Remark	Action
HEALTH CHECKS				
Hygienic conditions at labour camps OL				
Availability of First Aid facilities				
Proper sanitation at site, officer and labour camps				
Arrangements of medical facility				
Measures for dealing with illness				
Availability of potable drinking waters for workmen & staff.				
Provision of cretches for children.				
ERECTION				
Slings / D ^s shakle checked				
Signal Man				
Tag line for guiding the load				
Protecting the slings from sharp edges				
No loose materials at height				
Ladder & platform welding inspected				
No one under the suspended load				
Stay rope				
SWL				

Signature of Resident
Engineer with Seal



**LAYING AND CONSTRUCTION
OF 8” NB UNDERGROUND STEEL
PIPELINE AND ASSOCIATED
WORK**



TENDER DOCUMENT NO
REPL/SGL/STPL/009/22

Date: -28/11/2022

ANNEXURE-B

Format-3

3.0 ACCIDENT REPORT

(To be submitted by Contractor after every accident within 2 hours of accident)

Report No. :

Date :

Name of Site :

Contractor :

NAME OF THE INJURED

FATHER’S NAME

SUB-CONTRACTOR M/S.

DATE & TIME OF ACCIDENT

LOCATION

BRIEF DESCRIPTION OF ACCIDENT

CAUSE OF ACCIDENT

NATURE OF INJURY / DAMAGE

MEDICAL AID PROVIDED / ACTIONS TAKEN

INTIMATION TO LOCAL AUTHORITIES

DATE :

SIGNATURE OF CONTRACTOR
WITH SEAL

To. : Owner
RCM/SITE-IN-CHARGE, REPL

1 Copy
1 Copy



**LAYING AND CONSTRUCTION
OF 8” NB UNDERGROUND STEEL
PIPELINE AND ASSOCIATED
WORK**



TENDER DOCUMENT NO
REPL/SGL/STPL/009/22

Date: -28/11/2022

ANNEXURE-B
Format-4

4.0 SUPPLEMENTARY ACCIDENT & INVESTIGATION REPORT

Project : Supplementary to Report No.
(Copy enclosed)
Site : Date :
Contractor :

NAME OF THE INJURED
FATHER’S NAME
SUB-CONTRACTOR M/S.
DATE & TIME OF ACCIDENT
LOCATION

BRIEF DESCRIPTION OF ACCIDENT

CAUSE OF ACCIDENT

NATURE OF INJURY / DAMAGE

MEDICAL AID PROVIDED / ACTIONS TAKEN

INTIMATION TO LOCAL AUTHORITIES

DATE : SIGNATURE OF CONTRACTOR
WITH SEAL

To. : Owner 1 Copy
RCM/SITE-IN-CHARGE, REPL 1 Copy



**LAYING AND CONSTRUCTION
OF 8" NB UNDERGROUND STEEL
PIPELINE AND ASSOCIATED
WORK**



TENDER DOCUMENT NO
REPL/SGL/STPL/009/22

Date: -28/11/2022

5.0 MONTHLY Health, Safety & Environment (HSE) REPORT
(To be submitted by each Contractor)

Actual work start Date :

For the Month of :

Project :

Report No.

Name of the Contractor

Status as on :

Name of Work :

Name of Safety Officer :

Item	This Month	Cumulatx
Total Strength (Staff-Workmen)		
Number of HSE meeting organized at site		
Number of HSE awareness programmes Conducted at site		
Whether workmen compensation policy taken	Y/N	
Whether workmen compensation	Y/N	
Whether workmen registered under ESI Act	Y/N	
Number of Fatal Accident		
Number of Loss Time Accident (other than Fatal)		
Other accident (Non Loss Time)		
Total No. of Accident		
Total Man-hours worked		
Man-hour loss due to fire and accident		
Compensation cases raised with Insurance		
Compensation cases resolved and paid to workmen		
Remark		

DATE :

SIGNATURE OF CONTRACTOR
WITH SEAL

To. : Owner
RCM/SITE-IN-CHARGE, SGL

1 Copy
1 Copy



Sabarmati Gas Ltd.



(A Joint Venture of GSPC and BPCL)

SABARMATI GAS LIMITED

**LAYING, INSTALLATION, TESTING AND COMMISSIONING OF 8"
DIA. STEEL GAS PIPELINE CONNECTIVITY IN PATAN GA**

RESONANCE ENERGY PVT. LTD.

**Specification for Pipeline Markers
Tender No. REPL/SGL/STPL/009/22**

	LAYING AND CONSTRUCTION OF 8” NB UNDERGROUND STEEL PIPELINE AND ASSOCIATED WORK	
TENDER DOCUMENT NO REPL/SGL/STPL/009/22		Date: -28/11/2022

CONTENTS

- 1 SCOPE
- 2 REFERENCE CODES AND DRAWING
- 3 GENERAL
- 4 AERIAL MARKERS
- 5 KILOMETRE MARKERS
- 6 PIPELINE WARININGS SIGN
- 7 ROW BOUNDARY MARKERS
- 8 DIRECTION MARKERS
- 9 NAVIGABLE WATERWAY PIPELINE CROSSING WARNING SIGN



LAYING AND CONSTRUCTION OF 8” NB UNDERGROUND STEEL PIPELINE AND ASSOCIATED WORK



TENDER DOCUMENT NO
REPL/SGL/STPL/009/22

Date: -28/11/2022

1 **SCOPE**

- 1.1 This specification covers the minimum requirements for supply, fabrication and erection of pipeline markers to be installed by CONTRACTOR at various locations along the route of a cross – county pipeline
- 1.2 This specification shall be read in conjunction with the conditions of all specification and documents in the CONTRACT between COMPANY and CONTRACTOR

2 **REFERENCE CODES**

Reference has been made in this specification to the latest revision of the following code :

API RP 1109 : Recommended practice for marking liquid petroleum pipeline facilities

3 **GENERAL**

- 3.1 CONTRACTOR shall supply fabricate and install the pipeline marked along the pipeline route. The locations of markers as indicated in the approved drawings shall be treated for guidance purposes only and the exact location of the markers shall be based on AS BUILT drainage and as directed by COMPANY.
- 3.2 The pipeline markers shall be fabricated and installed in accordance with the COMPANY standard drawings included herein. Before start of fabrication of the markers, CONTRACTOR shall prepare and submit for COMPANY'S approval the detailed scheme for the marker plates as applicable for the project.
- 3.3 The pipeline markers shall be installed, as far as possible at locations such that to cause no hindrance to the regular use of the land or to the traffic.

4 **AERIAL MARKERS**

Aerial markers shall in general in installed along the pipeline at every five (5) kilometres intervals and at places specified by COMPANY. Refer COMPANY Standard Drawing No SGL/TS/08/10A for details

5 **KILOMETRE MARKERS**

Kilometer marker shall in general be installed along the pipeline between the aerial markers at every one (1) kilometer interval. Markers shall indicate cumulative



**LAYING AND CONSTRUCTION
OF 8” NB UNDERGROUND STEEL
PIPELINE AND ASSOCIATED
WORK**



TENDER DOCUMENT NO
REPL/SGL/STPL/009/22

Date: -28/11/2022

distance in kilometers from the reference station as directed by COMPANY. A kilometer marker is not required in the relative length between its location and any pipeline warning sign is less than 200 metres. Refer COMPANY Standard Drawings.

6. PIPELINE WARNING SIGN

Pipeline Warning sign shall in general be installed at

- National and State Highway Crossings (2 Nos.)
- Other Road Crossings (1 No.)
- Railway Crossings (2 Nos.)
- Minor Water Crossings (less than 15 m width (1 No.)
- Minor Water Crossings (above 15m width (2 Nos.)
- Major Water Crossings (2 Nos.)
- Valve Station (1 No.)
- And at any other location as shown in the approved drawing and as directed by the COMPANY

A marker shall be marked in bold and legible local language and Hindi /English with at least the following:

- Name of CGD Network Operating Company
- Contact Telephone Number to report emergency.
- Location Area Code
- Warning - “High Pressure Gas Line, Dial before Digging” etc

7. ROW BOUNDARY MARKERS

Right – of – Way boundary markers shall be fabricated and installed along entire network as per the drawing at every 100 meters in urban area and 200 meters within industrial parks. These shall be installed on either side of the pipeline alignment to define the ROW boundary limits. These shall also be installed at pipeline turning points to maintain the continuity of the ROW limits. Refer COMPANY Standard Drawings.

8. DIRECTION MARKERS

Direction markers as shown in COMPANY Standard Drawing Shall be installed to identify the significant turning points of the pipeline during aerial traverse. One direction marker shall be installed at each turning point., in addition, two more



**LAYING AND CONSTRUCTION
OF 8” NB UNDERGROUND STEEL
PIPELINE AND ASSOCIATED
WORK**



**TENDER DOCUMENT NO
REPL/SGL/STPL/009/22**

Date: -28/11/2022

direction markers shall be installed along the pipeline alignment, one on either side of the turning point at 200m from the turning point.

9 NAVIGABLE WATERWAY PIPELINE CROSSING WARNING SIGN

The Navigable Waterway Pipeline Crossing Warning Sign shall be fabricated in accordance with COMPANY Standard Drawing No. Such Warning sign shall be installed one on each bank of navigable water courses at the pipeline crossing location, in lieu of the pipeline Warning sign described in clause 6.0 of this specification.



Sabarmati Gas Ltd.

(A Joint Venture of GSPC and BPCL)

SABARMATI GAS LIMITED

**LAYING, INSTALLATION, TESTING AND COMMISSIONING OF 8”
DIA. STEEL GAS PIPELINE CONNECTIVITY IN PATAN GA**

RESONANCE ENERGY PVT. LTD.

**Specification for Flushing and Testing
Tender No. REPL/SGL/STPL/009/22**

0	25/11/2022	Issued for RFP	AS	PG	PC
Rev.	Date	Description	Prepared By	Checked By	Approved By



**LAYING AND CONSTRUCTION
OF 8" NB UNDERGROUND STEEL
PIPELINE AND ASSOCIATED
WORK**





**TENDER DOCUMENT NO
REPL/SGL/STPL/009/22**

Date: -28/11/2022

CONTENTS

1. Scope
2. Inspection
3. Flushing
4. Testing
5. General requirement/test preparation for testing
6. Testing media, Test pressure and test pressure gauges
7. Testing procedure
8. Completion of Testing
9. Test records

	LAYING AND CONSTRUCTION OF 8” NB UNDERGROUND STEEL PIPELINE AND ASSOCIATED WORK	
TENDER DOCUMENT NO REPL/SGL/STPL/009/22		Date: -28/11/2022

1. **SCOPE**

This specification covers the general requirements for Inspection, flushing and testing of piping systems.

Flushing and testing of all piping system shall be witnessed by the Engineer-in-charge / PMC/ TPIA.

2. **INSPECTION**

During various stage and after completion fabrication and erection, the piping system shall be inspected by the Engineer-in-charge to ensure that



- Proper piping material been used.
- Piping has been erected as per drawings and the instruction of the engineer-in charge.
- All supports have been installed correctly.
- Test preparations motioned in this specification have been carriedout.

3. **FLUSHING**

Flushing of all lines shall be done before pressure testing. Flushing shall be done by fresh portable water or dry compressed air, wherever water flushing is not desirable, to clean the pipe of all dirt, debris or loose foreign materials.

Required pressure of water, flushing shall meet the fire hydrant pressure or utility water pressure. For air flushing the line, system will be pressurised by compressed air at the required pressure which shall be 50 psi maximum. The pressure shall then be released by quick opening of a valve, already in the line for this purpose. This procedure shall be repeated as many times as required till the inside of the pipe is fully cleaned.

In line instruments like control valves, orifice plates, rot meters, safety valves and

	LAYING AND CONSTRUCTION OF 8” NB UNDERGROUND STEEL PIPELINE AND ASSOCIATED WORK	
TENDER DOCUMENT NO REPL/SGL/STPL/009/22		Date: -28/11/2022

other instruments like them wells which may interfere with flushing shall not be include I m the flushing circuit.

From all permanent strainers the screen / meshes shall be removed before flushing. Screens / meshes shall be re-installed after flushing but before testing.

In case an equipment such as column, vessel, exchanger etc. forms part of a piping circuit during flushing, this shall be done with the approval of Engineer-in-charge. However equipment thus included in the circuit, shall be completely cleaned and dried with compressed air, after flushing is completed.



During flushing discharged water/air shall be drained at the place directed the Engineer-in-charge. If necessary, proper temporary drainage shall be provided by the contractor.

Care shall be taken during flushing so as not to damage/ spoil work of other agencies. Precautions shall also be taken to prevent entry of water/ foreign matter into equipment, electric motors, instruments, electrical installations etc. in the vicinity of lines being flushed.

The contractor shall carry out all the activities required before, during and after the flushing operation, anasing because of flushing requirements, such as but not limited to the following.

Dropping of valves, specials distance pieces, online instruments and any other piping part before flushing. The flanges to disengage for this purpose shall be envisaged by the contractor and approved by the Engineer-in-charge. These flanges shall be provided with temporary gaskets at the time of flushing.

After flushing is completed and approved, the valve, distance pieces, piping specials etc. shall be re-installed by the contractor with permanent gaskets. However, flanges of equipment nozzles and other places where isolation is required

	LAYING AND CONSTRUCTION OF 8” NB UNDERGROUND STEEL PIPELINE AND ASSOCIATED WORK	
TENDER DOCUMENT NO REPL/SGL/STPL/009/22		Date: -28/11/2022

during testing, only temporary gaskets shall be provided.

Records in triplicate shall be prepared and submitted by the contractor for each piping system for the flushing done in the proforma in exhibit

4 **Testing**

With the exclusion of instrumentation. Piping system fabricated or assembled in the field shall be tested irrespective of whether or not they have been pressure tested prior to site welding of fabrication.

To facilitate the testing of piping systems, vessels and other equipments may be included in the system with the prior approval of Engineer-in-charge if the test pressure specified is equal to or less than that for the vessels and other equipments.



Pumps, compressors and other rotary equipments shall not be subjected to field test pressures.

Lines which are directly open to atmosphere such as vents, drains, safety valves, discharge need not be tested, but all joints shall be visually inspected wherever necessary such lines shall be tested by continuous flow of fluid to eliminate the possibility of blockage. However, such lines if provided with block valve shall be pressure tested up to the first block valve.

Seats of all valves shall not be subjected to a pressure in excess of the maximum cold welding pressure of the valve. Test pressure applied to valves shall not be greater than the manufacturer's recommendation nor less than that required by the applicable code. Where desirable set pressure is less than test pressure, test shall be made through an open valve.

Instruments in the system to be tested, shall be excluded from the test by isolation or removal, unless approved otherwise by the Engineer-in-charge. Restrictions which interfere with filling, venting and drawing such as orifice plates etc. shall not be installed unless testing is complete.

Control valves shall not be included in the test system. Where by-passes are provided test shall be performed through the by-pass end/or necessary spool shall

	LAYING AND CONSTRUCTION OF 8” NB UNDERGROUND STEEL PIPELINE AND ASSOCIATED WORK	
TENDER DOCUMENT NO REPL/SGL/STPL/009/22		Date: -28/11/2022

be used in place of the control valve.

-Pressure gauges which are of the finished system, but cannot withstand test pressure shall not be installed until the system has been tested. Where piping systems to be tested are directly connected at the battery limits to piping for which the responsibility rests with other agencies, the piping to be tested shall be isolated from such piping by physical disconnection such as valves or blinds.

5 General Requirement/ Test preparation for Testing

Test shall be carried out with permanent gaskets installed unless specified otherwise or instructed by the Engineer-in-charge.



No pressure test shall be carried out against close valve unless approved by the Engineer-in-charge.

The Engineer-in-charge shall be notified in advance by the contractor, of the testing sequence and programme, to enable him to be present for witnessing the test. The contractor shall be fully responsible for making arrangements with the local boiler inspector to witness the tests for steam lines falling under IBR. IBR certificates for these tests shall be obtained in the relevant IBR forms and furnished to the Engineer-in-charge. Before testing, all piping shall be cleaned by flushing to make it free from dirt, loose scale, debris and other loose foreign materials.

All piping systems to be hydrostatically tested shall be vented at the high points and the systems purged of air before the test pressure is applied.

Wherever in the line any void is existing due to any reasons, for absence of control valve, safety valve, check valves etc. it shall be filled with temporary spools.

All joints welded, screwed or flanged shall be left exposed for examination during the test. Before pressuring the lines, each weld joint shall be cleaned by wire brush to free it from rust and any other foreign matter.

	LAYING AND CONSTRUCTION OF 8” NB UNDERGROUND STEEL PIPELINE AND ASSOCIATED WORK	
TENDER DOCUMENT NO REPL/SGL/STPL/009/22		Date: -28/11/2022

Where a system is to be isolated of a pair of companion flanges, a blank shall be inserted between the companion flanges. Minimum thickness of the blank shall be designed in accordance with applicable design code.

Open ends of piping system where blanks cannot be used, such as pumps, compressors, turbines or wherever equipment or pipe spool have been received or disconnected prior to hydrostatic testing, shall be blinded – off by using standard blind flanges of same rating as the piping system being tested.

Pressure gauges used in testing shall be installed as close as possible to the lowest point in the piping system to be tested, to avoid overstressing of any of the lower portion of the system. For longer lines and vertical lines, two or more pressure gauges shall be installed at locations selected by the Engineer-in-charge. For lines containing check valves any of the following alternatives shall be adopted for pressure testing. Wherever possible pressurize up-stream side of valve.



Replace the valve by a temporary spool and re-install the valve after testing.

Provide blind on valve flanges and test the upstream and downstream of the line separately and remove the blind after testing. All these flanges, temporary gaskets shall be provided during testing and shall be replaced by permanent gaskets subsequently. For check valves in lines- 1-1/2” and below, flapper or seat shall be removed during testing (if possible). After completion of testing the flopper/ seat shall be refitted.

Gas lines when hydrostatically tested shall be provided with additional temporary supports during testing as directed by Engineer-in-charge.

Piping which is spring or counter-weight supported shall be temporarily supported, where the weight of the fluid would overload the support. Retaining pins for spring supports shall be removed only after testing is completed and test fluid is completely drained.

When testing any piping system, air or steam of approximately 2kg/ cm²

	LAYING AND CONSTRUCTION OF 8" NB UNDERGROUND STEEL PIPELINE AND ASSOCIATED WORK	
TENDER DOCUMENT NO REPL/SGL/STPL/009/22		Date: -28/11/2022

(g) may be used as preliminary test to detect missing gaskets etc. as this avoids the necessity of purging the gas to make repairs. However, this method may not be used for this purpose, if the steam temperature is more is more than the design temp. of the line.

For jacketed pipes testing of core pipes shall be done on individual pieces where the pipe is continuously packed, before it is jacketed. The outer jacket shall be tested separately as a system for piping with discontinuous jacketing, the core pipe and the jacket shall be tested as separate system.

6 Testing media, test pressure and test pressure gauges

6.1 Testing Modes

In general all pressure test shall be hydrostatic using iron free water, which is clean and free of silt. Maximum chlorine content in water for hydrostatic testing for MS piping shall be 15-20 ppm. Air shall be used for testing only if water would cause corrosion of the system or overloading of supports etc. in special cases as directed by Engineer-in-charge.

Where air/ water tests are undesirable substitute fluid such as gas, oil, methanol etc. shall be used as the testing medium, with due consideration to the hazards involved. These test fluids shall be specified in the line list given to the contractor.



6.2 Test Pressure

The hydrostatic/ pneumatic test pressure shall be as indicated in the linelist or as per the instruction of Engineer-in-charge.

The selection of the piping system for one individual test shall be based on the following:-

Test pressure required as per line list.

Maximum allowable pressure for the material of construction of piping depending

	LAYING AND CONSTRUCTION OF 8" NB UNDERGROUND STEEL PIPELINE AND ASSOCIATED WORK	
TENDER DOCUMENT NO REPL/SGL/STPL/009/22		Date: -28/11/2022

upon the above requirements and based on construction progress, maximum length of piping shall be included

6.3 Test Pressure Gauge

All gauge used for testing shall have suitable range so that the test pressure of the various system falls in 40 % to 60 % of gauge scale range. Gauge shall be of a good quality and in first class working condition.

Prior to the start of any test or periodically during the field test programmes, all test gauges shall be calibrated using a standard dead weight gauge tester or other suitable approved testing apparatus. Any gauge having an incorrect zero reading or error of more than $\pm 2\%$ of full scale range shall be discarded. The Engineer-in-charge shall check the accuracy of master pressure gauge used for calibration.

7 Testing procedure

7.0.1 Hydrostatic Test



All vents and other connections used as shall be kept open while filling the line with test fluid for complete removal of air. For pressurising and depressurising the system, temporary isolating valves shall be provided if valves, vents, drains do not exist in the system.

Pressure shall be applied only after the system/ line is ready and approved by the Engineer-in-charge.

Pressure shall be applied by means of a suitable test pump or other pressure source which shall be isolated from the system as the desired test pressure is reached and stabilised in the system.

A pressure gauge shall be provided at the pump discharge for guiding the system to the required pressure.

The pump shall be attended constantly during the test by an authorised person. The pump shall be isolated from the system wherever the pump is to be left unattended.

	LAYING AND CONSTRUCTION OF 8" NB UNDERGROUND STEEL PIPELINE AND ASSOCIATED WORK	
TENDER DOCUMENT NO REPL/SGL/STPL/009/22		Date: -28/11/2022

Test pressure shall be maintained for a sufficient length of time to permit through inspection of all joints for leakage or signs of failure. Any joint found leaking during a pressure test, shall be re-tested to the specified pressure after repair. Test period shall be maintained for a minimum of three hours.

The pump and the piping system to be tested are to be provided with separate pressure indicating gauges. These gauges are to be checked by the standard test gauge before each pressure test.

Care shall be taken to avoid increase in the pressure due to atmospheric variations during the test.

7.0.2 Air Test

When testing with air, pressure shall be supplied by means of a compressor. The compressor shall be portable type with a receiver after cooler & oil separator.

Piping to be tested by air shall have joints covered with a soap and water solution so that the joint can be examined for leaks.



All other activities shall be same as per hydro testing procedure (Specified above).

8 Completion of Testing

After the hydrostatic test has been completed, pressure shall be released in a manner and at a rate so as not to endanger personnel or damage equipments.

All vents and drains shall be opened before the system is to be drained and shall remain open till all draining is complete, so as to prevent formation of vacuum in the system. After draining lines/ systems shall be dried by air.

After testing is completed the test blinds shall be removed and equipment/ piping isolated during testing shall be connected using the specified gaskets, bolts and

	LAYING AND CONSTRUCTION OF 8” NB UNDERGROUND STEEL PIPELINE AND ASSOCIATED WORK	
TENDER DOCUMENT NO REPL/SGL/STPL/009/22		Date: -28/11/2022

nuts. These connections shall be checked for tightness in subsequent pneumatic tests to be carried out by the contractor for complete loop/circuit including equipments (except rotary equipments).

Pressure tests shall be considered complete only after approved by the Engineer-in-charge. Defects, if any, noticed during testing shall be recited immediately and retesting of the system/ line shall be done by the contractor at his cost.

9 Test Records

Records in triplicate shall be prepared and submitted by the contractor for each piping system, for the pressure test done in the proforma as given in Exhibit „F“.



Sabarmati Gas Ltd.

(A Joint Venture of GSPC and BPCL)

SABARMATI GAS LIMITED

**LAYING, INSTALLATION, TESTING AND COMMISSIONING OF 8"
DIA. STEEL GAS PIPELINE CONNECTIVITY IN PATAN GA**

RESONANCE ENERGY PVT. LTD.

**Specification for Piping Material
Tender No. REPL/SGL/STPL/009/22**



**LAYING AND CONSTRUCTION
OF 8" NB UNDERGROUND STEEL
PIPELINE AND ASSOCIATED
WORK**





TENDER DOCUMENT NO
REPL/SGL/STPL/009/22

Date: -28/11/2022

CONTENTS

1.0	SCOPE
2.0	CODES AND STANDARDS
3.0	MATERIAL SPECIFICATION
4.0	CLASS DESIGNATION CODE
5.0	PIPELINE
6.0	PIPING
7.0	FITTINGS
8.0	BENDS
9.0	FLANGES
10.0	GASKETS
11.0	BOLTING
TABLE-1	PIPE WALL THICKNESS DETAILS FOR LINE
TABLE-2	INDEX OF PIPING MATERIALS SPECIFICATION

	LAYING AND CONSTRUCTION OF 8” NB UNDERGROUND STEEL PIPELINE AND ASSOCIATED WORK	
TENDER DOCUMENT NO REPL/SGL/STPL/009/22		Date: -28/11/2022

1.0 **Scope**

This specification covers the requirements of various piping materials used in piping/ pipeline system handling natural gas and associated utilities in the pipeline.

2.0 **Codes and Standards**

- 2.1 Pipeline and terminal facilities envisaged as a part of this project shall be designed and Engineered primarily in accordance with the provision of ASME B 31-8 Gas Transmission and Distribution piping system 1995 edition.
- 2.2 All codes standards and specifications referred herein shall be the latest edition of such documents.
- 2.3 For sake of brevity, the initials of the society to which the codes are referred are omitted in the specification, for example, B16.5 is a code referring to ANSI/ ASME, A 105 is a code referring to ASTM.
- 2.4 In addition, COMPANY specifications for various piping and pipeline materials shall also be applicable.

3.0 **Material Specification**

Piping material specifications are classified for the general purpose of selection of material for the class of services. The maximum design pressure and design temperature together with the fluid in line governs the selection of material specification. Deviation of materials from class specifications may occur due to specific design condition. These deviations are permissible if they are equal or better than the individual class requirements.

4.0 **Class Designation Code**

The piping class designation consists of three digit numbering system made up of letter, number, letter e.g. A1A, B1A, D1A, etc as follows:

First letter indicates ANSI class rating e.g.



LAYING AND CONSTRUCTION OF 8" NB UNDERGROUND STEEL PIPELINE AND ASSOCIATED WORK



TENDER DOCUMENT NO
REPL/SGL/STPL/009/22

Date: -28/11/2022

A-Class 150

B-Class 300

C-Class 600

The middle number indicates differences in the specification within the same rating and material.

The last letter indicates type of material e.g. Carbon steel

5.0 **Pipeline**

The material for line pipe shall be as per the requirements of specification as indicated in table- I.

6.0 **Piping**

6.1 Carbon steel pipe shall be made by open hearth, electric furnace or basic oxygen process only. The steel used shall be fully killed and made with fine grain structure. The grade and wall thickness of various sizes of pipes shall be as per piping material specification for the applicable class.

6.2 Pipe dimension shall be in accordance with ANSI B 36.10 for carbon steel pipes and ANSI B 36.19 for stainless steel pipes.

6.3 All pipe threads shall conform to American Standard taper as per ANSI B 1.20.1 NPT, unless otherwise specified.

6.4 For butt weld end, bevel shall be in accordance to ANSI B 16.25/ API 5L as applicable.

7.0 **FITTINGS**

7.1 Fully killed carbon steel shall be used in the manufacture of fittings.

7.2 Threaded joints, if used shall conform to American standard taper as per ANSI 1.20.1 NPT.

7.3 Dimension of socket weld/ screwed fitting shall conform to ASME B 16.11.

7.4 Bore of socket welded fittings shall suit old. OF Pipe and its thickness.

7.5 Dimensions of butt welded carbon steel fitting upto size 18" NB shall conform to ASME



**LAYING AND CONSTRUCTION
OF 8” NB UNDERGROUND STEEL
PIPELINE AND ASSOCIATED
WORK**



TENDER DOCUMENT NO
REPL/SGL/STPL/009/22

Date: -28/11/2022

B 16.9/ MSS-SP-75 as applicable.

- 7.6 Butt welding ends shall conform to ANSI B 16.25/ API 5L. in case of difference in thickness of matching ends, requirements of ASME B 31.8 shall apply.
- 7.7 Intergrally reinforced forged branch fitting such as sockolet, threadolet, weldolet, nipple etc. shall be as per MSS-SP-97. Fittings not covered in ASME B 16.9 and MSS-SP-97, shall conform to manufacturer’s standard.

8.0 **Bends**

- 8.1 Unless otherwise specified for terminal piping, the elbow of radius $R = 1.5 D$ shall only be used.
- 8.2 For pipeline cold field bends with radius $R = 40D$ (Where D is pipe O. D) for 18” NB shall be used. Limited used of long radius bends ($R=6D$) may be permitted for reason of space constraints.

9.0 **Flanges**

- 9.1 Flange rating shall be same as ANSI class rating unless otherwise specified.
- 9.2 Dimensions of flanges shall be in accordance with ANSI B 16.5 for sizes up to 18” NB.
- 9.3 Neck Of Weld Neck (WN) flanges to suit pipe bore and thickness.
- 9.4 Bore of Socket Welded (SW) flanges shall suit pipe O.D. and its thickness.
- 9.5 Threads for screwed flanges if used shall conform to American Standard taper as per ANSI B 1.20 1 NPT.
- 9.6 Sizes for blind flanges shall be indicated by nominal pipe sizes.
- 9.7 Carbon Steel flanges faces shall have serrated finish or smooth finish as indicated in the material specification. Flanges faces shall have serrated finish to 250-500 micro inches AARH as per ANSI B 16.5 for ANSI class 150# and smooth finish to 125-200 micronches AARH as per MSS-SP-6 for ANSI class 300# & 600 #.
- 9.8 Butt welding ends of WN flanges shall conform to ANSI B 16.25
- 9.9 Spectacle blind/ spacer & blinds for sizes up to and including sizes 18” NB shall be in accordance with API standard 590/ SGL standard. Spectacle blind shall be used for sizes upto 8” NB and for 10” & above spacer & blind shall be used.



**LAYING AND CONSTRUCTION
OF 8” NB UNDERGROUND STEEL
PIPELINE AND ASSOCIATED
WORK**



TENDER DOCUMENT NO
REPL/SGL/STPL/009/22

Date: -28/11/2022

9.10 Two jack screws 180° apart shall be provided for all spectacle blind assemblies. The jack screws shall be as per SGL'S standard, attached with this specification.

10.0 GASKETS

10.1 Spiral wound metallic gaskets shall conform to B 16.20 and shall be provided with compressed asbestos filler. All spiral wound gaskets shall be provided with carbon steel centering ring. Gasket thickness shall be as indicated in piping material specification for the applicable piping class.

10.2 Non metallic compressed asbestos gaskets for flanged pipe joints shall conform to B16.21 unless specified otherwise, asbestos material shall conform to IS 2712 Gr. 0/1. Gasket thickness shall be as indicated in piping material specification for the applicable piping class.

11.0 Bolting

11.1 Nuts for stud bolts shall be American standard hexagonal heavy. Series and double chamfered.

11.2 Dimension and tolerances for stud bolts and nuts shall be as per ANSI B 18.2.1 and 18.2.2 with full threading to ANSI B 1.1 Class 2A thread for bolts and class 2B for nuts. Diameter and length of stud bolts shall be as per ANSI B 16.5 with full threading.

11.3 Threads for nuts shall as per ANSI B 1.1, as follows : Nuts

for stud dia 1/4” TO 1” : UNC-2B

Nuts for stud bolts dia 1 1/8” to 3 1/4” : 8UN-2B

11.4 Threads for stud bolts shall be as per ANSI B 1.1, as follows .Studs

bolts dia 1/4” to 1” : UNC- 2A

Stud bolts dia 1 1/8” to 3 1/4” : 8UN-2A

11.5 Heads of jack screws shall be heavy hexagonal type. Jack screw end shall be rounded. Stud bolts shall be fully threaded with two hexagonal nuts.



	LAYING AND CONSTRUCTION OF 8" NB UNDERGROUND STEEL PIPELINE AND ASSOCIATED WORK	
TENDER DOCUMENT NO REPL/SGL/STPL/009/22		Date: -28/11/2022

Table : 1

MAIN LINE PIPE MATERIAL

Sl. No.	Pipe Material Description	Size (NB)	Thickness (mm)	Length
2.	API 5L Gr. X-52, PSL-2	8"	6.4 mm	As per SOR Quantity
3.	API 5L Gr. X-52, PSL-2	4"	6.4 mm	As per SOR Quantity

Table : 2

INDEX OF PIPING MATERIAL SPECIFICATIONS

Piping Class	Service	Design pressure	Design Temp. 0C	C.A.in mm.	Basic Material	Design Code
AIA (150 #)	Natural Gas	19.0	65	1.5	APL 5L	ASME B 31.8
BIA (150#)	Natural Gas	49	65	1.5	API 5L	ASME B 31.8
DIA (150#)	Natural Gas	92	65	1.5	API 5L	ASME B 31.8

12.0 Thread Sealant

12.1 Threaded joints shall be made with 1" wide PTFE jointing tape.

13.0 VALVES

13.1 All valves installed above ground within the terminal of sizes 2" and above shall have flanged ends. Valves of size less than 2" shall have socket welded ends except for ball valves.

13.2 Flange dimensions and face finish of flanged end valves shall confirm to clause 9.0 of this specification.

13.3 Butt welding ends of butt welded valves shall confirm to ANSI B 16.25



**LAYING AND CONSTRUCTION
OF 8" NB UNDERGROUND STEEL
PIPELINE AND ASSOCIATED
WORK**



TENDER DOCUMENT NO
REPL/SGL/STPL/009/22

Date: -28/11/2022

- 13.4 Face to face and end to end dimensions shall confirm to applicable standards.
- 13.5 Buried valves on mainline shall be provided with stem extension, sealant, vent/ drain & shall have butt welded ends.
- 13.6 Sectionlising valves (block valves) installed on the main pipeline shall have butt welded ends and shall be full bore to allow smooth passage of cleaning pigs as well as intelligent pigs.
- 13.7 Unless specified otherwise. Valves shall confirm to the following standards.

Screwed/ Socket welded / flanged end valves (1 1/2" and below)

Ball valves	-	BS 5351
Plug Valves	-	BS5353
Check Valves	-	BS 5352
Globe Valves	-	BS 5352
Gate Valves	-	API 602



Flanged/ Butt weld end valves (2" and above)

Ball Valves	-	API 6D
Plug Valves	-	API 6D
Check Valves	-	BS 1868
Globe Valves	-	BS 1873
Gate Valves	-	API600

- 13.8 Valve operators shall be as indicated below, unless specified otherwise in theP&ID.

a) **Gate and globe valves**

- i) For ANSI Class 150 and 300 - Hand wheel operated for size < 12"NG
Gear operated for size >14" NG.

	LAYING AND CONSTRUCTION OF 8” NB UNDERGROUND STEEL PIPELINE AND ASSOCIATED WORK	
TENDER DOCUMENT NO REPL/SGL/STPL/009/22		Date: -28/11/2022

- ii) For ANSI class 600 - Hand wheel operated for size < 10” NB
Gear operated for size >12” NB.

b) Ball and plug valves

- i) For ANSI class 150, 300, 600 - Wrench operated for size < 4” NB.
Gear operated for size < 6” NB.

14. Quick opening end closure

Quick opening end closure to be installed on scraper traps shall be equipped with safety locking in compliance with section VII, division 1, UG- 35 (b) of ASME boiler and pressure vessel code.

15. Hydro testing vents and drains

High point vents and low point drains required for the purpose of hydro testing shall be of size 0.75” and consist of socket, gate valve, flange & blind flange.

16. Pipeline speciality items

Pipeline Specialty items viz., Scraper Traps, Flow Tee, Insulating Joints, LR bends, QOEC for Venting shall be as per respective data sheets, specifications and Project Specific drawing showing Mainline & Terminal materials.



Sabarmati Gas Ltd.

(A Joint Venture of GSPC and BPCL)

SABARMATI GAS LIMITED

**LAYING, INSTALLATION, TESTING AND COMMISSIONING OF 8”
DIA. STEEL GAS PIPELINE CONNECTIVITY IN PATAN GA**

RESONANCE ENERGY PVT. LTD.

**Documentation for Pipeline Construction
Tender No. REPL/SGL/STPL/009/22**

0	25/11/2022	Issued for RFP	AS	PG	PC
Rev.	Date	Description	Prepared By	Checked By	Approved By



**LAYING AND CONSTRUCTION
OF 8" NB UNDERGROUND STEEL
PIPELINE AND ASSOCIATED
WORK**



TENDER DOCUMENT NO
REPL/SGL/STPL/009/22

Date: -28/11/2022

C O N T E N T S

1. SCOPE
2. RECORDS
3. AS-BUILT DRAWINGS AND PIPE BOOK



**LAYING AND CONSTRUCTION
OF 8" NB UNDERGROUND STEEL
PIPELINE AND ASSOCIATED
WORK**



TENDER DOCUMENT NO
REPL/SGL/STPL/009/22

Date: -28/11/2022

1.0 SCOPE

1.1 This specification covers the minimum requirements of various records reports and drawings for all aspects of pipeline construction to be prepared by Contractor and submitted to the Company at intervals as described in this specification and as directed by Company.

1.2 All document required to prepared and submitted by contractor as per this specification shall be in addition to the various reports, records, methodology statement, calculation drawing etc to be submitted by the Contractor for Company's record review or approval as per the requirements of all other specification included in the Contract between the Company and Contractor.



1.3 This specification shall be read in conjunction with the conditions of all specifications and document included in the Contract between Company and Contractor.

2.0 RECORDS

Contractor shall submit daily, weekly monthly and after completion to the Company, various records and reports for company's documentation purpose during and immediately after the construction. This shall as minimum include, but not limited to the following :

2.1 Daily

- Separate progress reports of all crews
- Daily welding results and repairs
- Actual weather conditions
- Application for deviations, if any
- Accidents
- Darnages
- Activities required from Company
- Materials Receipts
- Urgently required materials

	LAYING AND CONSTRUCTION OF 8” NB UNDERGROUND STEEL PIPELINE AND ASSOCIATED WORK	
TENDER DOCUMENT NO REPL/SGL/STPL/009/22		Date: -28/11/2022

2.2 Weekly

- Up – to date list of confirmed site instruction issued by company
- Materials „taken over“
- Material defects and repairs
- Outstanding activities of Company
- List of installed markers, chainage
- Required approval from Company
- Progress planned
- Reports of manning of all crews equipment and plant
- Report of equipment and plant
- Report of accidents
- Report of damages
- Report of acquired release, permits

- Priced variations
- Required materials for next month

2.3 **Monthly**

Progress report for payment, safety report, report of accidents, security report, health and environment report, material balance approved deviations.

2.4 Further Contractor shall supply (for approval if required to the Company with documents such as but not limited :

- Organogram for construction work.
- Bio-data of key personnel (including foremen)
- (Revised) list of address of personnel in particular of medical staff, safety and security offers.



LAYING AND CONSTRUCTION OF 8" NB UNDERGROUND STEEL PIPELINE AND ASSOCIATED WORK



TENDER DOCUMENT NO
REPL/SGL/STPL/009/22

Date: -28/11/2022

- (Revised) list of approved coaters.
- (Revised) list of approved sub – contractors.
- Time schedule.
- Acquired permits and/ or approvals from Authorities, if any.
- Minutes of meeting with Company with comments, if any.
- Material certificates, material receipt.
- Guarantee from vendors and sub – contractor.
- Calculations, Temporary work bouyance, blasting.
- Drawings issued by contractor.
- Vendors drawings.
- As- built of route maps alignment sheets details drawingsand isometric drawing
- Procedure such as surveying stacking fencing
- Welding procedure qualification record, radiographic procedure qualification welder qualification.
- Coating procedure
- Installation of crossings.
- Hydrostatic testing
- Blasting.
- Radiographic report alongwith original radiographs
- Pipe and welding book
- **Reports**
 - Material tests (coating, welding painting)
 - Computerised Potential Logging Test
 - Water Samples
 - Cleaning, Pigging Report before Hydrostatic Test
 - Hydrostatic Test
 - Calibration Test
 - Blasting Trials
 - Equipment certificate (dead weight tester, instruments vessels equipment)



LAYING AND CONSTRUCTION OF 8" NB UNDERGROUND STEEL PIPELINE AND ASSOCIATED WORK



TENDER DOCUMENT NO
REPL/SGL/STPL/009/22

Date: -28/11/2022

- Manuals
- Major water crossings
- Waste disposal
- Disposal of water after hydrostatic test.

2.5 Contractor shall submit to company colour photographs of various construction activities / operations at regular intervals. Size number and frequency of the photographs shall be mutually agreed upon at a later stage. Also Contractor shall make video recordings of all operations right from the start of construction till the completion of the work, covering to the extent as instructed by company and submit to Company. Upon completion of the work contractor and submit edited master tape plus six copies of video recording in VHS formats or any format ordered by the Company. The duration of Video recording shall be of ½ hour and shall cover all aspects of the job.

3.0 AS – BUILT DRAWINGS AND PIPE BOOK

3.1 General



Contractor shall prepare “as – built” drawings of all by or on behalf of Company issued drawing and of all Contractor work drawings including vendor drawing, such as but not limited to :

For Pipeline Section :

- Route Maps
- Alignment Sheets
- Detail Drawing (road, railway, minor water crossings, major water crossings, valley crossings)
- Isometric drawings of installations
- Special installation

Further Contractor shall prepare a pipe Weld Book

If required by the Company, Contractor shall update the diskettes for drawings issued for construction of the job.

	LAYING AND CONSTRUCTION OF 8” NB UNDERGROUND STEEL PIPELINE AND ASSOCIATED WORK	
TENDER DOCUMENT NO REPL/SGL/STPL/009/22		Date: -28/11/2022

3.2 “As – Built” Drawings

Contractor shall prepare a complete set of “as-built” drawings. From the start of construction, contractor shall on daily basis process any changes in two sets drawings. Deleted [parts shall be indicated in red new parts in blue, remarks in green and unchanged parts in yellow. Said drawings shall be kept at site and be available to company at all times. Contractor shall prepare “as-built” drawings based on these data. On completion of the work one revised film transparency of all drawing made “as-built” by contractor containing the “as-built” information shall be handed over to Company as well as one complete set of CD ROM/ Floppy diskettes as specified by Company.

Contractor shall prepare and submit a specimen of the layout of the drawing for Company’s approval.

The required measurement for “as-built” drawing shall executed by Contractor by experienced qualified surveyors.

The surveyors shall daily take care of all measurement required such as but not limited to :

- Horizontal location of pipeline with regard to deviations and permanent Grid Pillars.
- Vertical Level with regard to Mean Sea Level of pipeline and grade.
- Location and type of bends, fittings etc. and grades, points of intersection.
- Change of wall thickness materials.
- Location and details of valves, insulating flanges, fencing.
- Location and details of crossing pipes, vents.
- Location and type of coating.
- Location and type of weighting anchoring.
- Location and type of markers.
- Location of further appurtenance (pig-Signallers)
- Location of ROU and of pipeline with respect to ROU.
- Type of soil



LAYING AND CONSTRUCTION OF 8" NB UNDERGROUND STEEL PIPELINE AND ASSOCIATED WORK



TENDER DOCUMENT NO
REPL/SGL/STPL/009/22

Date: -28/11/2022

- Type of rock
- Type of blasting and ripping.
- Sand padding.
- Type of road pavement.
- Details of bank protection, number of insulators seals. Contractor shall also prepare isometric drawing of all installation (facilitates) etc. for which the data as mentioned in or required for the pipe and Welding Book can be identified and these drawings can also be used for material accounting.

3.3 Nameplates of Equipment

All permanent equipment supplied and installed by Contractor shall be provided with plates by Contractor: All texts shall be submitted to Company for approval before plates may be manufactured.

3.4 Pipe Book

Every page of the pipe and Welding Book shall mention :

- Date relevant to the project and section thereof.
- Sequential number.
- Length brought forward (for pipes and other materials).
- Length bring forward (for pipes and other materials). Alignment sheet number and at least the location thereon of two welds on every page of the pipe Book.

Further,

- Diameter of pipeline
- Length of each pipe
- Wall thickness
- Pipe number
- Heat number certificate number
- Cut and re-numbered pipe ends
- Coating type
- Date of stringing
- Date of welding



**LAYING AND CONSTRUCTION
OF 8” NB UNDERGROUND STEEL
PIPELINE AND ASSOCIATED
WORK**



**TENDER DOCUMENT NO
REPL/SGL/STPL/009/22**

Date: -28/11/2022

- Direction of working
- Heat treatment
- Equipment used for radiography
- Limits of water crossings
- Test pressure and date of test.

In order to achieve this, Contractor shall identify all pipe elements. Sample format of pipe Book shall be submitted for Company approval

3.5 As- Built Documents

Contractor shall prepare all documents in the prescribed format as indicated below. In addition to the three hard copies, three copies of final documents shall also be submitted in electronic media i.e. CD ROM / floppy diskettes.

Software used for the preparation of these documents shall be as follows :

Type document	Software
a) Reports / Documents	MS Office
b) Drawing	Auto CAD

For the purpose of preparation as as-built drawing, Contractor shall update the “Issued for construction” drawings issued by the Company. It shall be Contractor responsibility to covert the drawings furnished by the Company in hard copy into CAD drawings including scanning, digitizing and converting the drawing s into a suitable format compatible with the Auto CAD and above. As-Built drawings shall be prepared only on AutoCAD drawings.



Sabarmati Gas Ltd.

(A Joint Venture of GSPC and BPCL)

SABARMATI GAS LIMITED

**LAYING, INSTALLATION, TESTING AND COMMISSIONING OF 8”
DIA. STEEL GAS PIPELINE CONNECTIVITY IN PATAN GA**

RESONANCE ENERGY PVT. LTD.

**Specification for Seamless Fittings and Flanges
Tender No. REPL/SGL/STPL/009/22**

0	25/11/2022	Issued for RFP	AS	PG	PC
Rev.	Date	Description	Prepared By	Checked By	Approved By



**LAYING AND CONSTRUCTION
OF 8" NB UNDERGROUND STEEL
PIPELINE AND ASSOCIATED
WORK**



TENDER DOCUMENT NO
REPL/SGL/STPL/009/22

Date: -28/11/2022

CONTENTS

- 1.0 SCOPE
- 2.0 REFERENCE DOCUMENTS
- 3.0 MANUFACTURE'S QUALIFICATION
- 4.0 MATERIALS
- 5.0 DESIGN AND MANUFACTURE
- 6.0 INSPECTION AND TESTS
- 7.0 TEST CERTIFICATES
- 8.0 MARKING



LAYING AND CONSTRUCTION OF 8" NB UNDERGROUND STEEL PIPELINE AND ASSOCIATED WORK



TENDER DOCUMENT NO
REPL/SGL/STPL/009/22

Date: -28/11/2022

1. **SCOPE**

This specification covers the minimum requirements for the design, manufacture and supply of following items to be installed in pipeline system handling hydrocarbons in liquid or gaseous phase.

- Seamless fittings 400 mm (16") NB and smaller, such as tees, elbows, reducers and caps.
- Flanges 400 mm (16") NB and smaller, such as welding neck flanges and blind flanges.

The specification does not cover the above mentioned items which are to be installed in pipeline system handling sour hydrocarbons (liquid/gas) service as defined in NACE standard MR-01-75-98.

2. **REFERENCE DOCUMENTS**

Reference has been made in this specification to the latest edition of the following codes, standards and specifications:

- a) ASME B 31.8
Gas Transmission and Distribution Piping systems.
- b) ASME B 31.4
Liquid Transportation Systems for Hydrocarbons, Liquid Petroleum Gas, Anhydrous Ammonia and Alcohols.
- c) ASME B 16.5
Steel Pipe Flanges and Flanged Fittings.
- d) ASME B 16.9
Factory – Made – Wrought Steel Butt Welding Fittings.
- e) ASME B 16.11
Forged Steel Fittings, Socket Welding and Threaded
- f) ASTM A 370
Mechanical Testing of Steel Products
- g) API 590



**LAYING AND CONSTRUCTION
OF 8” NB UNDERGROUND STEEL
PIPELINE AND ASSOCIATED
WORK**



TENDER DOCUMENT NO
REPL/SGL/STPL/009/22

Date: -28/11/2022

- h) Steel Line Blanks
MSS-SP-25
Standard Marking System for Valves, Fittings, Flanges and Unions
- i) MSS-SP-44
Steel Pipeline Flanges
- j) MSS-SP-75
Specification for High Test Wrought Welded Fittings.
- k) MSS-SP-97
Forged Carbon Steel Branch Outlet Fittings – Socket Welding, Threaded and Butt Welding Ends.

3. MANUFACTURERE’S QUALIFICATION

Manufacturer who intends bidding for fittings must possess the records of a successful proof test, in accordance with the provisions of ASME B 16.9 / MSS-SP-75, as applicable. These records shall be submitted at the time of bidding.

4. MATERIALS

4.1. The basic material for fittings and flanges shall be as indicated in the Material Requisition. Additionally, the material shall also meet the requirements specified hereinafter.

4.2. Each heat of steel used for the manufacture of fittings and flanges shall have carbon equivalent (CE) not greater than 0.45 calculated from check analysis in accordance with following formula :

$$CE = C + \frac{Mn}{6} + \frac{Cr + Mo + V}{5} + \frac{Ni + Cu}{15}$$

Carbon contents on check analysis shall not exceed 0.22%

4.3. Unless specified otherwise, Charpy V-notch test shall be conducted for each heat of steel, in accordance with the impact test provision of ASTM A370 at 0°C temperature. The average absorbed impact energy values of three full-sized



**LAYING AND CONSTRUCTION
OF 8" NB UNDERGROUND STEEL
PIPELINE AND ASSOCIATED
WORK**



TENDER DOCUMENT NO
REPL/SGL/STPL/009/22

Date: -28/11/2022

specimens shall be 27 joules.

The minimum impact energy value of any one specimen of the three specimens analysed as above, shall not be less than 80% of the above mentioned average value.

4.4. Steel Used shall be fully Killed.

4.4.1. Hardness : testing shall be carried out by Manufacturer in accordance with ASTM A 234. Hardness testing shall cover at least 10% per item, per size, per heat per manufacturing method.

5. DESIGN AND MANUFACTURE

5.1. Flanges such as welding neck flanges and blind flanges shall conform to the requirements of ASME B 16.5 Spectacle blind, spacer & blind shall conform to API 590.

5.2. Fittings such as tees, elbows and reducers shall be seamless type and shall conform to ASME B 16.9 for Sizes 50 mm (2") NB and above and ASME B16.11 for sizes below 50mm (2") NB.

5.3. Fittings such as weldolets, sockolets, nippolets, etc., shall be manufactured in accordance with MSS-SP-97.

5.4. Type, face and face finish of flanges shall be as specified in Material Requisition.



5.5. Stub-in or pipe to pipe connection shall not be used in the manufacture of tees. Tees shall be manufactured by forging or extrusion methods. The longitudinal weld seam shall be kept at 90° from the extrusion. Fittings shall not have any circumferential joint.

5.6. All butt weld ends shall be beveled as per ASME B16.25.

5.7. Repair by welding on flanges and parent metal of the fittings is not allowed.

6. INSPECTION AND TESTS.

6.1. The Manufacturer shall perform all inspections and tests as per the requirement of this specification and the relevant codes, prior to shipment at his works. Such inspections and tests shall be, but not limited to, the following :

	LAYING AND CONSTRUCTION OF 8" NB UNDERGROUND STEEL PIPELINE AND ASSOCIATED WORK	
TENDER DOCUMENT NO REPL/SGL/STPL/009/22		Date: -28/11/2022

- 6.1.1. Visual inspection
- 6.1.2. Dimensional checks.
- 6.1.3. Chemical composition, mechanical properties and hardness examination.
- 6.1.4. All finished wrought weld ends shall be 100% ultrasonically tested for lamination type defects. Any lamination larger than 6.35 mm shall not be acceptable.
- 6.1.5. All other tests not specifically listed but are required as per applicable standard/specification.
- 6.2. Purchaser's Inspector may also perform stage-wise inspection and witness tests as indicated in Clause 6.1 at Manufacturer's Works prior to shipment. Manufacturer shall give reasonable notice of time and shall provide, without charge, reasonable access and facilities required for inspection to the purchaser's Inspector. Inspection and tests performed / witnessed by the Purchaser's Inspector shall in no way relieve the Manufacturer's obligation to perform the required inspection and tests :

7. TEST CERTIFICATES

Manufacturer shall submit following certificates to Purchaser's Inspector :

- a) Test certificates relevant to the chemical analysis and mechanical properties of the materials used for construction as per this specification and relevant standards.
- b) Test reports on non-destructive testing.

8. MARKING

Each item shall be marked with indelible paint with the following date;

- a) Manufacturer's marking
- b) Material Specification
- c) Size and schedule number
- d) Heat number



Sabarmati Gas Ltd.

(A Joint Venture of GSPC and BPCL)



SABARMATI GAS LIMITED

**LAYING, INSTALLATION, TESTING AND COMMISSIONING OF 8”
DIA. STEEL GAS PIPELINE CONNECTIVITY IN PATAN GA**

RESONANCE ENERGY PVT. LTD.



**Technical Specification for Pre-Commissioning and
Commissioning
Tender No. REPL/SGL/STPL/009/22**

0	25/11/2022	Issued for RFP	AS	PG	PC
Rev.	Date	Description	Prepared By	Checked By	Approved By

	LAYING AND CONSTRUCTION OF 8” NB UNDERGROUND STEEL PIPELINE AND ASSOCIATED WORK	
TENDER DOCUMENT NO REPL/SGL/STPL/009/22		Date: -28/11/2022

C O N T E N T S

1. INTRODUCTION
2. GENERAL
3. THE WORK
4. PRE – COMMISSIONING CHECKS
5. DOCUMENTATION

	LAYING AND CONSTRUCTION OF 8" NB UNDERGROUND STEEL PIPELINE AND ASSOCIATED WORK	
TENDER DOCUMENT NO REPL/SGL/STPL/009/22		Date: -28/11/2022

1.0 INTRODUCTION

This specification covers the minimum technical requirements for pre-commissioning and commissioning of gas pipeline, including pre-commissioning activities such as pre-commissioning checks, flushing of terminal piping, dewatering, swabbing and nitrogen purging

2.0 GENERAL

The scope of work for testing and commissioning including pre-commissioning activities shall include, but not limited to the manpower, machinery & equipment, detailed procedures, materials and consumables, communications etc. to perform the work satisfactorily.

Contractor shall prepare detailed procedures for flushing of terminal piping, dewatering, swabbing, inertisation and commissioning of the pipeline, covering all aspects of work for company's approval. This shall include, but not limited to, the sequence and description of all operations, data on materials, equipment, instruments, consumables, communications systems, necessary calculations, detailed time schedule and organization chart.

The Contractor shall be responsible for demonstrating the successful completion of all the activities i.e. flushing of terminal piping, dewatering, swabbing, inertisation and commissioning of the pipeline. All necessary work to perform the job successfully including necessary modifications required shall be the responsibility of the Contractor.

Contractor shall design and supply all temporary line connections, valves, instruments, etc. as required during the various operations.

In the event of any detail which is not fully addressed, it is warranted by Contractor that work shall be performed in accordance with company's specification and the best recognized practices in the on-shore pipeline industry.

3.0 THE WORK

The work to be performed by the Contractor shall consist of the following activities.

- | | |
|---------------------|--|
| Pre-commissioning : | Entire pipeline project shall be checked with respect to latest P&ID's and other design specification. |
| Dewatering : | Removal of hydrotest water from the entire pipeline network system. |
| Swabbing : | Reducing the amount of remaining water in the main pipeline system which is left behind after completion |



LAYING AND CONSTRUCTION OF 8" NB UNDERGROUND STEEL PIPELINE AND ASSOCIATED WORK



TENDER DOCUMENT NO
REPL/SGL/STPL/009/22

Date: -28/11/2022

of the dewatering operations to make the pipeline free of water.

- Inertisation : Intertising the entire pipeline with nitrogen.
- Commissioning : Charging the entire pipeline network with the product and achieving normal operating conditions of the Pipeline.

4.0 PER-COMMISSIONING CHECKS

4.1 The pre-commissioning checks shall be carried out of for the pipeline to ascertain the pipeline system has been mechanically completed in all respects. These checks shall cover the main pipeline including distribution network system and Sectionalizing valve stations. The pre-commissioning checks shall include the following:

i) System Checks

The entire facilities shall be checked against the latest P&ID's and other design specification code

ii) Checking of Field Instruments

All the field instruments like control valves, sectionalizing valves, transmitters, solenoid valves, shut down switches, alarms etc. shall be checked physically and also for their intended application by simulating the operating conditions. It will also include checking of different meters, gauges action of shutdown valves etc. as applicable.

iii) Survey of the Pipelines

This shall be performed to confirm that proper fittings/supports, route markets, fencing around SV Stations etc.have been installed along the pipeline

iv) Checking of Communications System

This is to check that there is proper communications with adequate back-up power to ensure uninterrupted communication

v) Checking of Electrical Distribution System

This is to check that instrument controls and interlocks are functional as per the normal operating conditions.



LAYING AND CONSTRUCTION OF 8" NB UNDERGROUND STEEL PIPELINE AND ASSOCIATED WORK



TENDER DOCUMENT NO
REPL/SGL/STPL/009/22

Date: -28/11/2022

- vi) Checking of instruments, Controls & Interlocks
This is to check that instrument controls and interlocks are functional as per the normal operating conditions.
- vii) Checking of Utilities
This is to check that utilities like power, nitrogen, UPS system instrument air, etc. are available prior to startup.
- viii) Any other checks are may be considered necessary.

4.2 **DEWATERING**

4.2.1 **General**

During the dewatering operation the major quantity of hydrotest water shall be removed from the main pipeline and distribution network. It is the responsibility of the Contractor to develop suitable dewatering procedure and submit for Company's approval.

The disposal of the water shall be performed such that no harm is done to the environment.

4.2.2 **Operational Requirements**

The dewatering operation shall consist of number of dewatering pig runs when air is used as propellant for pig trains.

Bi-directional cup pigs shall be used and will be suitable for traversing the entire length of the pipeline/ pipe segment being dewatered. Contractor shall ensure that all the pigs are designed to prevent damage to the pipeline internal coating, if any.

The Contractor shall propose the minimum speed and the back pressure of the pigs in order that continuous operation will be performed without the pig getting struck. Contractor shall submit all the calculations regarding this procedure and a contingency plan for implementation in case the pigs get struck.

Contractor shall provide a suitable compressor for oil-free air with sufficient capacity and pressure.

Upon arrival of the pigs at the receiving end the Contractor in the presence of Company's representative shall remove the pigs without delay.

4.2.3 **Acceptance Criteria**

Before proceeding to the next stage of the inertisation operation Contractor shall ensure that bulk of the water has been removed from the pipeline. Contractor shall



LAYING AND CONSTRUCTION OF 8" NB UNDERGROUND STEEL PIPELINE AND ASSOCIATED WORK



TENDER DOCUMENT NO
REPL/SGL/STPL/009/22

Date: -28/11/2022

specify when the dewatering phase is finished and shall obtain approval of the company before proceeding to the next inertisation phase.

4.3 Swabbing

4.3.1 General

The swabbing operation is meant to reduce the remaining water in the pipeline into touch dry condition.

Swabbing operation shall be carried out to ensure that there is no free water left inside the pipeline. This is done by driving number of swabbing pigs so that the weight increase in pig before and after the swabbing operation is not more than 25%. The Contractor shall submit the detailed procedure along with the duration of the swabbing operation and obtain approval of the company before starting the operation.

4.3.2 Acceptance Criteria

The Contractor shall ensure that the swabbing operation is considered to be completed when it is established that there is no free water left in the pipeline and the pipeline has achieved a touch dry condition. This shall be subject to company's approval.

4.4 Inertisation

During the inertisation operation, the air left in the pipeline shall be replaced by nitrogen before admitting the product natural gas that the pipeline will ultimately carry.



The inertisation operation shall as soon as possible after the swabbing operation has been completed and approved by the company. Contractor shall submit the detailed purging procedure for approval for the company prior to its implementation.

Nitrogen needed for inertisation of the pipeline, shall be provided by the Contractor. The maximum allowable oxygen content inside the pipeline shall be less than 1 % by volume.

Multiple separation pigs with nitrogen slugs in between shall be used for pipeline commissioning. At least three batches of nitrogen separated by four separation pigs shall be used for inertisation of the pipeline during charging of gas in it. The combined nitrogen column length to be used for inertisation should be at least 5% of the total pipeline length.

4.4.1 Safety Review before start of commissioning

A pre-startup safety review shall be carried out of the pipeline system before

	LAYING AND CONSTRUCTION OF 8” NB UNDERGROUND STEEL PIPELINE AND ASSOCIATED WORK	
TENDER DOCUMENT NO REPL/SGL/STPL/009/22		Date: -28/11/2022

permitting entry of natural gas into the new facility. Owner/ Owner’s representative shall also participate in the pre-startup safety review.

4.5 COMMISSIONING

4.5.1 General

Commissioning of pipeline shall be considered completed when the line is charged with product natural gas at operating pressure and the total system operated at normal operating parameters for a minimum period of 72 hours with all the instruments, controls and interlocks working satisfactorily at normal operating conditions. Contractor shall submit a detailed commissioning procedure for company’s approval.

5.0 DOCUMENTATION

Contractor shall submit for approval of the company the complete description, detailed procedure and time schedule of all the dewatering, swabbing, purging and commissioning operations, as applicable

Documents shall also contain all procedures and safety plans to be followed while carrying out the activities.

Upon successful completion of the work, Contractor shall prepare a final report of the work which shall include necessary charts, diagrams, graphs, calculations, recordings, daily logs, measurements, details of the operation, etc. Report shall also include all certificates of calibration of instruments required together with records of calibration performed at site prior to the start of any operation.

5.1 Spares and Consumables

Supply of spares, tools and consumables for start-up & commissioning

5.2 Safety

- Appropriate Work Permit should be issued based on the kind of activity.
- Fire fighting equipments should be available during commissioning.
- Proper communication facilities should also be arranged.
- Follow the safety practice during execution of pre-commissioning/commissioning works as detailed in the scope of work. Maintain and follow all safety practices equivalent or better than those being practiced for the pipeline during pre-commissioning and commissioning.



Sabarmati Gas Ltd.

(A Joint Venture of GSPC and BPCL)



SABARMATI GAS LIMITED

**LAYING, INSTALLATION, TESTING AND COMMISSIONING OF 8”
DIA. STEEL GAS PIPELINE CONNECTIVITY IN PATAN GA**

RESONANCE ENERGY PVT. LTD.



**Quality Assurance System Requirements
Tender No. REPL/SGL/STPL/009/22**

0	25/11/2022	Issued for RFP	AS	PG	PC
Rev.	Date	Description	Prepared By	Checked By	Approved By

	LAYING AND CONSTRUCTION OF 8” NB UNDERGROUND STEEL PIPELINE AND ASSOCIATED WORK	
TENDER DOCUMENT NO REPL/SGL/STPL/009/22		Date: -28/11/2022

CONTENTS

1. INTRODUCTION
2. DEFINITIONS
3. CONTRACTORS SCOPE OF WORK
4. QUALITY ASSURANCE REQUIREMENTS

	LAYING AND CONSTRUCTION OF 8” NB UNDERGROUND STEEL PIPELINE AND ASSOCIATED WORK	
TENDER DOCUMENT NO REPL/SGL/STPL/009/22		Date: -28/11/2022

1.0 INTRODUCTION

This specification establishes the Quality Assurance Requirements to be met by the Sub-contractors (including turnkey Contractors) and their sub-vendors

In case of any conflict between this specification and other provisions of the contract/ purchase order, the same shall be brought to the notice of SGL, at the stage of bidding and shall be resolved with SGL, prior to the placement of order.

2.0 DEFINITION

Bidder

For the purpose of this specification, the word “Bidder” means the person(s) firm, company or organization who is under the process of being contracted by SGL/ Owner for delivery of some products (including service). The word is considered synonymous to supplier, contractor or vendor.

Correction

Action taken to eliminate the detected non-conformity.

Refers to repair, rework or adjustment and relates to the disposition of an existing non-conformity.

Corrective Action

Action taken to eliminate the causes of an existing non-conformity, defect or other undesirable situation in order to prevent recurrence.

Preventive Action

Action taken to eliminate the causes of a potential non-conformity, defect or other undesirable situation in order to prevent recurrence.

Process



Set of inter-related resources and activities which transform inputs into outputs.

Special Process

Processes requiring pre-qualification of their process capability.

3.0 CONTRACTORS SCOPE OF WORK

3.1 Prior to award of contract

	LAYING AND CONSTRUCTION OF 8” NB UNDERGROUND STEEL PIPELINE AND ASSOCIATED WORK	
TENDER DOCUMENT NO REPL/SGL/STPL/009/22		Date: -28/11/2022

The bidder shall understand scope of work, drawings, specifications and standards etc., attached to the tender/enquiry document, before he makes an offer.

The bidder shall submit milestone chart showing the time required for each milestone activity and linkages between different milestone activities alongwith overall time period required to complete the entire scope of work.

The bidder shall develop and submit manpower and resource deployment chart.

The bidder shall submit, along with the bid, a manual or equivalent document describing / indicating / addressing various control/check points for the purpose of quality assurance and the responsibilities of various functions responsible for quality assurance.

3.2 After the award of contract

The bidder shall submit the schedule for submission of following documents in the kick-off meeting or within two weeks of the placement of order, whichever is earlier.

- Detailed Bar Chart
- Quality plan for all activities, required to be done by the bidder, to accomplish offered scope of work.
- Inspection and test plans, covering various control aspects.
- Job procedures as required by SGL / REPL.
- Procurement schedule for items to be supplied by contractor covering inspection of the same.

Various documents submitted by the bidder shall be finalized in consultation with SGL / REPL. Here it shall be presumed that ones a bidder has made an offer, he has understood the requirements given in this specification and agrees to comply with them totality unless otherwise categorically so indicted during pre- award stage through agreed deviation / exception request. All Quality Assurance Plan (QAP) documents shall be reviewed by concerned functional groups of SGL

/ REPL and the bidder shall be required to incorporate all comments within the framework of this specification at this stage of the contract. It is also obligatory on the part of the bidder that obtains approval on every Quality Assurance Plan (QAP) documents, before he starts using a particular document for delivery of contracted scope of work. Participation of SGL / REPL in review/ approval of quality plan/ QAP documents does not absolve the contractor of his contractual obligations towards specified and intended use of the product (or service) provided/ to be provided by him under the contract.

3.3 During job execution

During job execution, the bidder shall fully comply with all quality document submitted and finalized/ agreed against the requirements of this specification.



**LAYING AND CONSTRUCTION
OF 8” NB UNDERGROUND STEEL
PIPELINE AND ASSOCIATED
WORK**



TENDER DOCUMENT NO
REPL/SGL/STPL/009/22

Date: -28/11/2022

Approval of SGL / REPL on all these documents shall be sought before start of work.

Bidder shall produce sufficient quality records on controlled/ agreed forms such that requirements give in this specification are objectively/ demonstrable.

Bidder shall facilitate SGL / REPL during quality/ technical audits at his works/sites.

Bidder shall discharge all responsibilities towards enforcement of this specification on all his sub-contractors for any part of the scope which is sub-contracted.

4.0 QUALITY ASSURANCE SYSTEM REQUIREMENTS

4.1 The bidder shall nominate an overall in-charge of the contract titled as “Project Manager” for the scope of work agreed contract. The name of this person shall be duly intimated to SGL / REPL including all subsequent changes, if any. SGL / REPL shall correspond only with the project manager of the bidder on all matters of the project. The manager of the bidder shall be responsible for co- ordination and management of activities with bidder’s organization and all sub- vendors appointed by the bidder.



After award of work, the bidder may review augmentation of man review augment of manpower and resource deployment chart (submitted earlier), detail it out, if so consented by SGL / REPL and resubmit the same as “issued for effective implementation of the project”.

4.2 The Bidder shall plan the contract scope of work on quality plan format such that no major variation is expected during delivery of contract scope of work. These quality plans shall be made on enclosed format complete in all respect. The quality plan shall be assumed to be detailing bidder’s understanding and planning for the contract/ offered scope of work. The bidder shall plan the type of resources including various work methodology which he agrees to utilize for delivery of contract scope of work.

4.3 The bidder is required to review the contract at all appropriate stages to evaluate his capabilities with respect to timely and quality completion of all activities pertaining with respect to timely and quality completion of all activities pertaining to contracted scope of work and shall report for constraints, if any to SGL / REPL.

4.4 The design activities, if any, performed during delivery of contract scope of work shall be so controlled that the outputs is reliable enough. It is expected that during development of design, the bidder shall take recourse to detailed checking, inter departmental reviews and documented verification methods.

4.5 For all documents which the bidder is likely to utilize for delivery of contract

	LAYING AND CONSTRUCTION OF 8” NB UNDERGROUND STEEL PIPELINE AND ASSOCIATED WORK	
TENDER DOCUMENT NO REPL/SGL/STPL/009/22		Date: -28/11/2022

scope of work, a system must exist which assures that latest/ required version(s) of the document(s) is available at all location/point of use.

4.6 In case the bidder decides to sub-contract any part/full of the contract scope of work (without prejudice to main Contractual condition), the bidder shall:

- Evaluate the technical and their products and/ or service before awarding them with the sub-contracted scope of work. Selection of a sub-contractor should meet SGL / REPL approval in documented form.
- Requirement of this specification shall be enforced on sub-contracted agency also. The bidder shall choose sub-contractor based on their capability to meet requirements of this specification also.

Note: It may so happen that, in a given situation, a sub-contractor may not have a system meeting the requirements of this specification. In all such eventualities, bidder may lend his system to sub-contractor for the contract such that sub-contractor effectively meets the requirements of this specification. In all such cases SGL / REPL shall be duly informed.



4.7 Bidder shall establish adequate methodology such that the materials supplied by SGL / REPL shall be adequately preserved, handled and made use of for the purpose for which they are provide.

4.8 All output delivered against contract scope of work shall be suitably identified in such a manner that either through identification or some other means, sufficient traceability is maintained which permits effective resolution of any problem reported in the outputs.

4.9 Critical activities shall be identified and the bidder is required to have documented methodologies. Which he is going to utilize for carrying out such activities under the contract scope of work. Wherever it is difficult to fully inspect or verify the output (special process), bidder shall pre-quality, the performers and methodologies.

4.10 All inspections carried out by the bidder’s surveillance/inspection staff shall be conformity to quality plans and/ or inspection and test plans. All inspection results shall be duly documented on controlled/ agreed forms such that results can be co-related to specific product that was inspected / tested.

4.11 All inspection, measuring & test equipments (IMTEs) shall be duly calibrated as

	LAYING AND CONSTRUCTION OF 8” NB UNDERGROUND STEEL PIPELINE AND ASSOCIATED WORK	
TENDER DOCUMENT NO REPL/SGL/STPL/009/22		Date: -28/11/2022

per National/ International standards/ codes and only calibrated and certified IMTEs shall be utilized for delivery of contract scope of work.

- 4.12** All outputs/ products delivered against contract scope of work shall be duly marked such that their inspection status is clearly evident during all stages/ period of the contract.
- 4.13** All non-conformities (NCs) found by the contractor’s inspection/surveillance staff shall be duly recorded, including their disposal action. The deficiencies observed during stage of product, shall be implemented by the bidder for all repetitive NCs, including deficiencies.
- 4.14** All deficiencies noticed by SGL / REPL shall be recorded on a controlled form. Such deficiencies shall be analysed by the bidder and effective and appropriate correction, corrective and preventive actions shall be implemented. Bidder shall intimate SGL / REPL of all such corrective and preventive action implemented by him.
- 4.15** Bidder shall establish appropriate methodologies for safe and effective handling, storage, preservation of various materials/ inputs encountered during delivery of contract scope of work.
- 4.16** Bidder shall prepare sufficient records for various processes carried out by him for delivery of contract scope of work such that requirements of this specification are objectively demonstrable. In case SGL / REPL finds that enough objective evidence/ recording is not available for any particular process, bidder shall be obliged to make additional records so as to provide sufficient objective evidence. The decision of SGL / REPL shall be final and binding on such issues.
- 4.17** The bidder shall arrange internal quality audits at quarterly intervals, to independently assess the conformance by various performers to the requirements of this specification. The findings of such assessment shall be duly recorded and a copy shall be sent to SGL / REPL for review.
- 4.18** For all special processes, bidder shall deploy only qualified performers. Wherever SGL observes any deficiency, the bidder shall arrange the adequate training to the performer(s) before any further delivery of work.



Sabarmati Gas Ltd.
(A Joint Venture of GSPC and BPCL)

SABARMATI GAS LIMITED



**LAYING, INSTALLATION, TESTING AND COMMISSIONING OF 8"
DIA. STEEL GAS PIPELINE CONNECTIVITY IN PATAN GA**

RESONANCE ENERGY PVT. LTD.

**REMOTE MONITORING & CONTROL OF T/R UNIT
PARAMETERS**



Tender No. REPL/SGL/STPL/009/22

0	25/11/2022	Issued for RFP	AS	PG	PC
Rev.	Date	Description	Prepared By	Checked By	Approved By

	<p>LAYING AND CONSTRUCTION OF 8” NB UNDERGROUND STEEL PIPELINE AND ASSOCIATED WORK</p>	
<p>TENDER DOCUMENT NO REPL/SGL/STPL/009/22</p>		<p>Date: -28/11/2022</p>

CONTENTS

- 1.0 SPECIAL REQUIREMENT – GSM BASED DATA LOGGER FOR REMOTE MONITORING & CONTROL OF T/R UNIT PARAMETERS
- 2.0 MANUFACTURER'S TECHNICAL EXPERTISE & EXPERIENCE IN THE FIELD OF CATHODIC PROTECTION RECTIFIERS
- 3.0 TESTING AND INSPECTION

	LAYING AND CONSTRUCTION OF 8” NB UNDERGROUND STEEL PIPELINE AND ASSOCIATED WORK	
TENDER DOCUMENT NO REPL/SGL/STPL/009/22		Date: -28/11/2022

1.0 SPECIAL REQUIREMENT – GSM BASED DATA LOGGER FOR REMOTE MONITORING & CONTROL OF T/R UNIT PARAMETERS

Wireless GSM Based Remote Monitoring & Control Data Logger for CP Rectifier Unit should be installed in each TR unit with following specifications:

1.1 General Description

The GSM based remote monitoring unit (RMU) Data Logger for Transformer Rectifier (TR) & CPPSM Unit monitoring, should be a highly accurate, compact, low power, low cost, micro - controller based unit with built -in GSM Modem which will enable continuous Centralized Monitoring of CP TR parameters at the central station as well on the 3 additional configured Mobile Phone numbers. The unit should provide C.P. T/R unit data by means of SMS sent to the programmed mobile nos.



This system should enable easy & wireless centralized monitoring of TR parameters like DC O/P Voltage, DC O/P Current, Reference Potential (P.S.P.), AC Supply Voltage & alarm conditions like Pipeline Overprotection, Pipeline Under protection, Reference fail , AC supply fail & T/R door open (for theft monitoring). The data logger should be suitable for installing in the existing TR/CPPSM Units and should directly accept signal inputs for various TR parameters without the need of any complex wiring or additional transducers.

The Data Logger should acquire data of all analog and digital parameters and transmit the same to the central station as well as up to 3 Nos. mobile phones of maintenance personnel, at the programmed periodic interval. In the event of any alarm, the data logger should instantly notify the user for the occurrence of alarm and give the data to the central station irrespective of the programmed periodic logging interval.

At the remote end, the Data could be received using a GSM interface module connected to the PC installed with the suitable CP Data Remote Monitoring CP Software. The Remote Monitoring software should display the acquired T/R data in the Analytical and graphical format and should store this data in the standard database like MS ACCESS or MS SQL, which can be used for generating, reports for further analysis of the structure under protection. The data logging & broadcast schedule should be fully programmable from 1 reading per 5 Minutes to one reading per day. In addition to this the data could also be directly receive d in the Mobile phones of maintenance personnel.

Apart from sending the TR data to the remote stations, this unit should also Log the data in its built-in internal Non-Volatile memory with accurate Day -Date-Time stamp for each reading at the programmed logging interval, thus it should also serve as a local data logger. The data logger should be capable of storing minimum of 1 Million total Data readings which can be downloaded on the field Laptop Computer reader using a USB data port provided in the data logger. The data stored in the internal memory should be retained for 10 years without any external power.

These Data Loggers should be of special design suitable for direct installation inside the existing C.P.

	LAYING AND CONSTRUCTION OF 8" NB UNDERGROUND STEEL PIPELINE AND ASSOCIATED WORK	
TENDER DOCUMENT NO REPL/SGL/STPL/009/22		Date: -28/11/2022

T/R units without need of any external Transducers or special Interface circuitry

1.2 Technical Data Sheet

a.	Item	: GSM Based Remote Monitoring Unit (RMU) Data Logger. Micro controller based intelligent CP TR/CPSSM Monitoring Unit with built -in GSM Modem.
b.	Make	: Kristron/Siemens/ ABB/Schneider/Allan Bradley/Raychem/iTech or equivalent
c.	Analog Inputs	: High accuracy, High Input Impedance > 10Mohms, 16-bit resolution Input with high common mode rejection ratio CMRR. <ul style="list-style-type: none"> ✓ CH-1: 0–100V DC (For DC Output Voltage) ✓ CH-2: 0-100mV DC (For DC Output Current through T/R shunt) ✓ CH-3: -4V to +4 V DC (For Reference potential) ✓ CH-4: 0 - 300V AC (For AC supply Voltage Monitoring)) ✓ CH-5: T/R unit run hours (AC supply Time Totalizer) (Accuracy of all the Analog Channels will be + 0.1%) It should also be possible to program the parameters for the above signals as desired, through the local keypad on the front panel of the Data Logger. There should be complete Galvanic Isolation between all the channels.
d.	Alarm Parameters	: The Data Logger should continuously scan and check for Alarm conditions listed below <ul style="list-style-type: none"> ✓ Over Protection ✓ Under Protection ✓ Reference Fail ✓ T/R Unit Door Open ✓ AC Supply Failure Facility should be provided to programme the levels for the above alarm conditions through the local keypad available on the front panel of the Data Logger.
e.	Control Parameters	: The Data Logger will have facility for Remote Control of following parameters: <ul style="list-style-type: none"> ✓ T/R unit DC O/P shutdown ✓ T/R unit Pipe Ckt ON/OFF



LAYING AND CONSTRUCTION OF 8" NB UNDERGROUND STEEL PIPELINE AND ASSOCIATED WORK



TENDER DOCUMENT NO
REPL/SGL/STPL/009/22

Date: -28/11/2022

f.	GSM Interface & Data Transmission	:	<ul style="list-style-type: none"> ✓ Built-In GSM Modem for broadcasting data to the Central Station at the programmed periodic interval. ✓ The Data should be transmitted in the form of standard SMS over any GSM Network. ✓ Data should be transmitted to Central Monitoring station & up to 3 additional mobile phones. ✓ All the data transmission Mobile nos. Should be easily programmable through local key pad and through remote computer
g.	Local Keypad & Display	:	<p>The Data Logger should have a 3 x 6 matrix membrane keypad and a 16 x 2 LCD Display with back-lighting for entering local settings and viewing TR/CPPSM parameters locally.</p> <p>Following Local settings can be done using the Key Pad & Display :</p> <ul style="list-style-type: none"> ✓ Setting Date/ Time ✓ Setting Start Time for Periodic sending of data to the Central station. ✓ Setting Periodic Logging Interval ✓ Setting of Scaling factor for DC shunt rating ✓ Setting levels for various Alarm notifications ✓ Entering cell numbers for Data & alarm notifications. ✓ Setting Field ID of the Logger <p>The LCD should normally display the following:</p> <ul style="list-style-type: none"> ✓ TR Voltage ✓ TR Current ✓ Reference Potential ✓ AC supply Voltage ✓ TR Run Hours ✓ GSM Signal Strength ✓ GSM SIM registrations. <p>It should also be possible to remotely configure the Data Logger for most of the above parameters from the central station.</p>
h.	Programmable Periodic Interval	:	<p>The Periodic Logging & Broadcast interval should be Programmable from 1 reading per 5 Minutes to 1 reading in 24 hours.</p>



LAYING AND CONSTRUCTION OF 8" NB UNDERGROUND STEEL PIPELINE AND ASSOCIATED WORK



TENDER DOCUMENT NO
REPL/SGL/STPL/015/22

Date: -28/11/2022

i.	Local Data Storage	:	<p>Logged Data should also be stored in the internal non - volatile Memory of the Data Logger. It should be possible to store minimum of One Million total Data readings in the Data Logger without downloading. Local Data retention should be up to 10 years without any external power.</p> <p>The Logged Data in the in the logger could be downloaded any time on a Laptop computer /Data reader using the USB communication port provided on the Data Logger. The Data Logger should be supplied with suitable Data downloading software which could be used to download the stored Data and also to programme the logger.</p>
j.	Time Stamping	:	The Unit should have precise, accurate Real Time Clock (RTC) for exact time stamping of data.
k.	Protection	:	The Input channels should have full protection against high voltage surges and continuous over voltages.
l.	Enclosure	:	<p>The unit should be housed in a compact & sturdy non corroding enclosure suitable for direct installation inside the existing T/R & CPPSM units at site.</p> <ul style="list-style-type: none"> ✓ Overall dimensions: 150mm x 100mm x 100mm. (Approx) ✓ Mounting : Wall mounting inside T/R unit ✓ Cable Entry : From Bottom
m.	Power Supply	:	<p>The Data Logger should accept any one of the following supplies:</p> <ul style="list-style-type: none"> ✓ 230V + 20% VAC ✓ 20V to 70V DC ✓ 12 VDC
n.	Battery Back-up	:	The Data logger should have built -in Battery Back-up for minimum 2 weeks of un-interrupted operation including GSM SMS transmission , in the event of failure of AC supply.
o.	Operating Environment	:	<ul style="list-style-type: none"> ✓ Temperature : -10 degree C to 75 degree C ✓ Humidity : 99% (RH)
p.	Communication Port	:	The Unit should have a USB port through which the logged data could be downloaded onto the laptop.



**LAYING AND CONSTRUCTION
OF 8” NB UNDERGROUND STEEL
PIPELINE AND ASSOCIATED
WORK**



TENDER DOCUMENT NO
REPL/SGL/STPL/015/22

Date: -28/11/2022

q.	Compliance	:	The Data Logger shall be complying to IEC – 60068-2-1 / IEC – 60068-2-2 / IEC – 60068-2-30 / IEC – 60068-2-78
Centralized Monitoring on a Control Room PC :			
r.	Centralised Monitoring	:	<p>Logger should have a built-in GSM modem to communicate with the central station over the GSM network.</p> <p>The Logger should send the TR Data with exact time stamp directly to the Master Computer at central station at the programmed Periodic Interval. At the central end a PC should be installed with a GSM Front End Communication (FEC) module and a suitably designed centralized monitoring software</p> <p>The Data Logger should also send alarm information with exact time stamp to the central station and the configured cell numbers, irrespective of the Periodic Interval.</p> <p>The central monitoring software should accept the data received from the field data logger and should display it in graphical and analytical formats and store it in database like MS ACCESS or MS SQL to generate Reports and Graphs.</p> <p>It should also be possible to remotely program the Field Data Logger Unit through the Central PC for configuration details like Setting Date/Time, Setting/ changing Periodic Interval and Setting of cell phone numbers for getting the data and alarm notifications.</p> <p>The remote Monitoring software should be capable of monitoring and receiving data from up to 50 field Data Loggers at a time.</p> <p>The software will be fully compatible with the data loggers in existing T/R unit of client.</p>

s.	Salient Features of Remote Monitoring Software	<p>✓ Operating System Monitoring software should be compatible to work with Operating system WINDOWS XP, WINDOWS VISTA & WINDOWS 7 and Latest OS.</p> <p>✓ Database Monitoring software should be compatible to work with SQL, MS Access database, also database operations should work in interactive mode without interfering data acquisition. Database should be easy maintainability and should be secure with having security level with password protection.</p> <p>✓ Mimic Display Monitoring Software should be able to display all TR units' parameters, with colour change for abnormal Values. Data for each TR units should be displayed station wise so the end user can view data at a glance. The Central Monitoring Software shall display the TR Parameter in mimic pages as:</p> <p>Overview</p>
----	--	---





**LAYING AND CONSTRUCTION
OF 8" NB UNDERGROUND STEEL
PIPELINE AND ASSOCIATED
WORK**



**TENDER DOCUMENT NO
REPL/SGL/STPL/015/22**

Date: -28/11/2022

		<p>This should display important parameters of maximum number of TR units in pages</p> <p>Individual Display This should display page with full details of the Individual TR Units.</p> <p>Area Wise View This should display parameters of TR units of a particular area. Software should have switching facility from one page to other just by click of mouse. Also software should be editable so that user can edit any time the Station name, Channel name, description, Unit name.</p> <p>✓ Configuration Monitoring Software should be able to send configuration commands to individual TR or all selected TR Station in one go. Below parameters of the RMU should be remotely settable through the central monitoring software:</p> <ul style="list-style-type: none"> • Date/ Time • Logging Interval • Handset number for Alarm Notification • Enable / Disable of the one particular Alarm or all Alarms numbers. <p>✓ Data Request User with help of monitoring software should be able to request for the instantaneous data for any TR station or all selected TR units in one go.</p> <p>✓ Auditing Monitoring software should have complete track for each of the action taken like application Log IN, Log Out, sending request for data, sending configuration to each TR station. Also all log information should be viewed in form of reports and should be easily exported to excel for further analysis.</p> <p>✓ Protection Monitoring software should have different level of password protection like Admin and normal user and should provide password. Software should also be able to assign rights to normal user so that any un even operation cannot be done to the real time working system. Software should have facility to lock the running application so that uneven operation cannot be done.</p> <p>✓ Reports Software should be able to generate all types of reports. Software should be able generate reports as per user demand like duration wise, daily monthly yearly. Separate and combine reports should be generated for analog and digital parameters. User should be able to select / deselect any required tags and same report should be</p>
--	--	---

	LAYING AND CONSTRUCTION OF 8” NB UNDERGROUND STEEL PIPELINE AND ASSOCIATED WORK		
TENDER DOCUMENT NO REPL/SGL/STPL/009/22		Date: -28/11/2022	
		<p>generated. For CP system it is prime important to have uptime reports so that it can have exact running of TR Units. Also all reports should be exported to PDF / Excel for further analysis.</p>	

2.0 MANUFACTURER'S TECHNICAL EXPERTISE & EXPERIENCE IN THE FIELD OF CATHODIC PROTECTION RECTIFIERS

The manufacturer should be a reputed and established manufacturer of CP Transformer Rectifier Units and should have experience in manufacturing of C.P. Transformer Rectifiers of similar specifications with built-in GSM based Data Loggers. The manufacturer will have to submit a list of C.P. Transformer Rectifier installations having similar specifications.

3.0 TESTING AND INSPECTION

The contractor shall provide all the necessary facilities to carry out full performance tests on the AC/DC operated C.P. Transformer Rectifier Units at his works. Test Certificates shall be furnished by manufacturer.

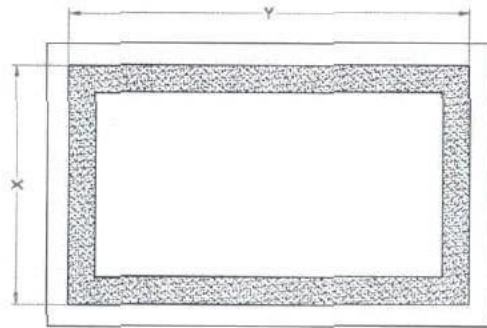

CENTRE LINE PLAN

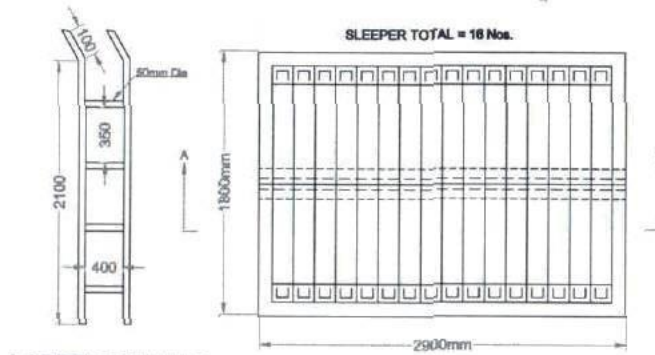

LADDER DETAILS

PLAN VIEW CLOSED

SLEEPER DIMENSION=1600 X 180 X 100



PLAN (SLEEPER)

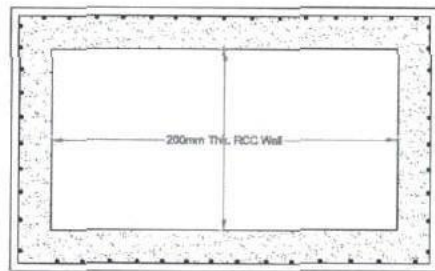

RCC WALL PLAN

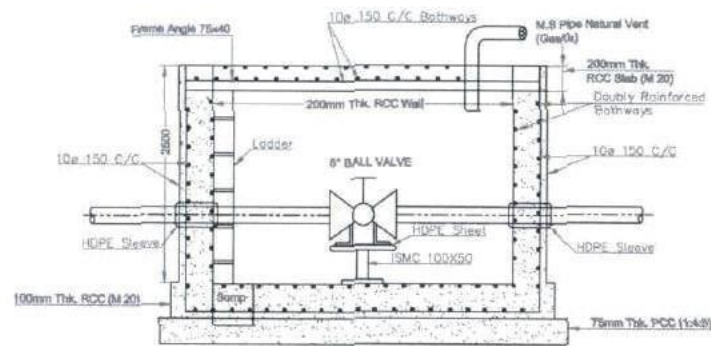

SECTION A-A (RAINFORCEMENT DETAILS)

Satyajit
Satyajit Shinde

Sg
Satyajit

NOTES :

1. All dimensions are in mm.
2. Concrete mix M25 grade.

NAME				
DATE				
SIGN.				
	PRED. BY	CHKD. BY	REVV. BY	APPD. BY
CLIENT: SABARMATI GAS LTD. GANDHINAGAR, GUJARAT				
PROJECT: Modification to existing steel valve chamber.				
TPA:				
CONTRACTOR:				
TITLE: PROPOSE DRAWING OF CIVIL VALVE CHAMBER				
SCALE	SHEET	DRAWING NO.	SIZE	REV
NTS	01 OF 01		A3	00

TYPICAL CNG CONNECTIVITY

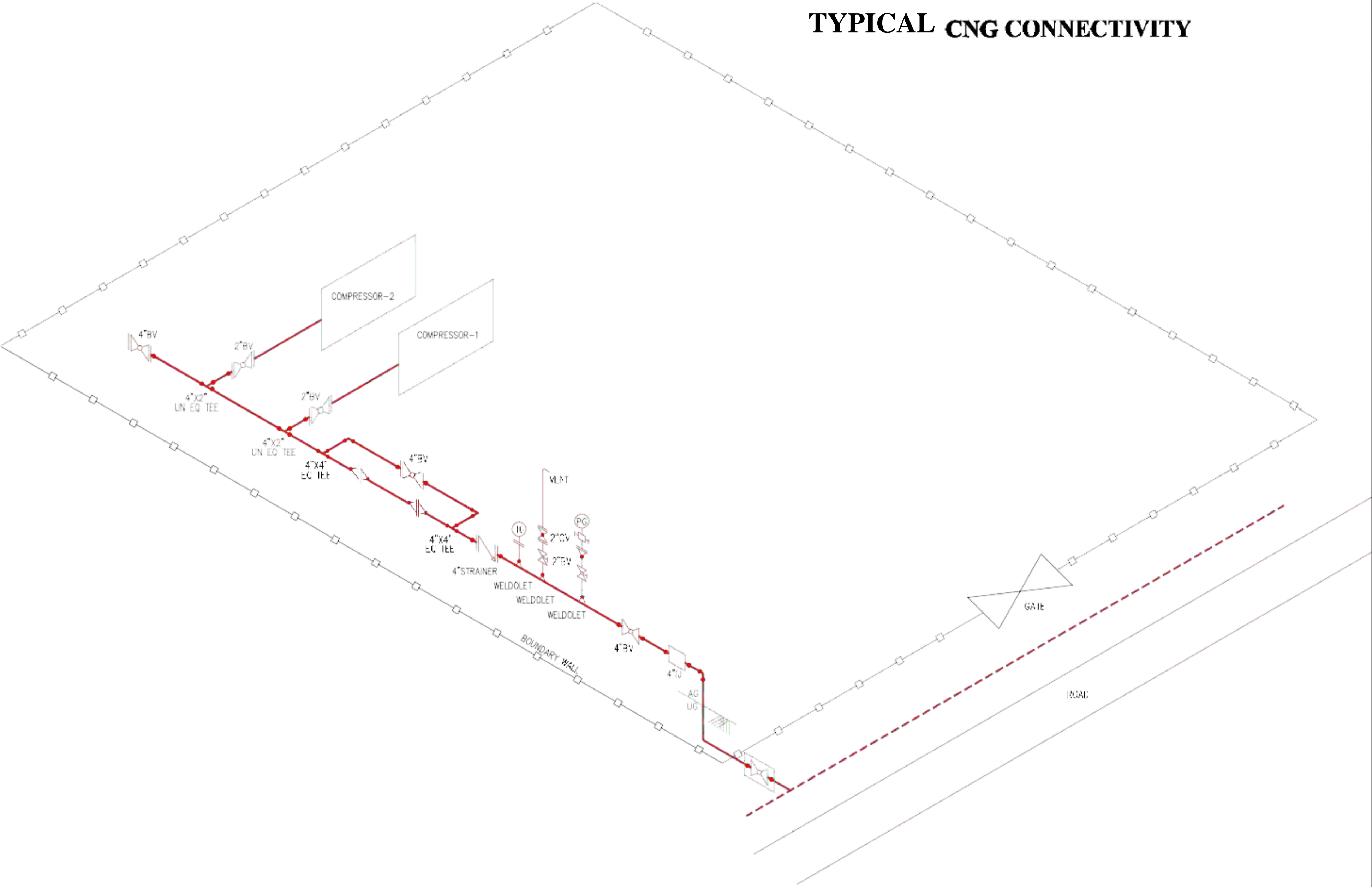

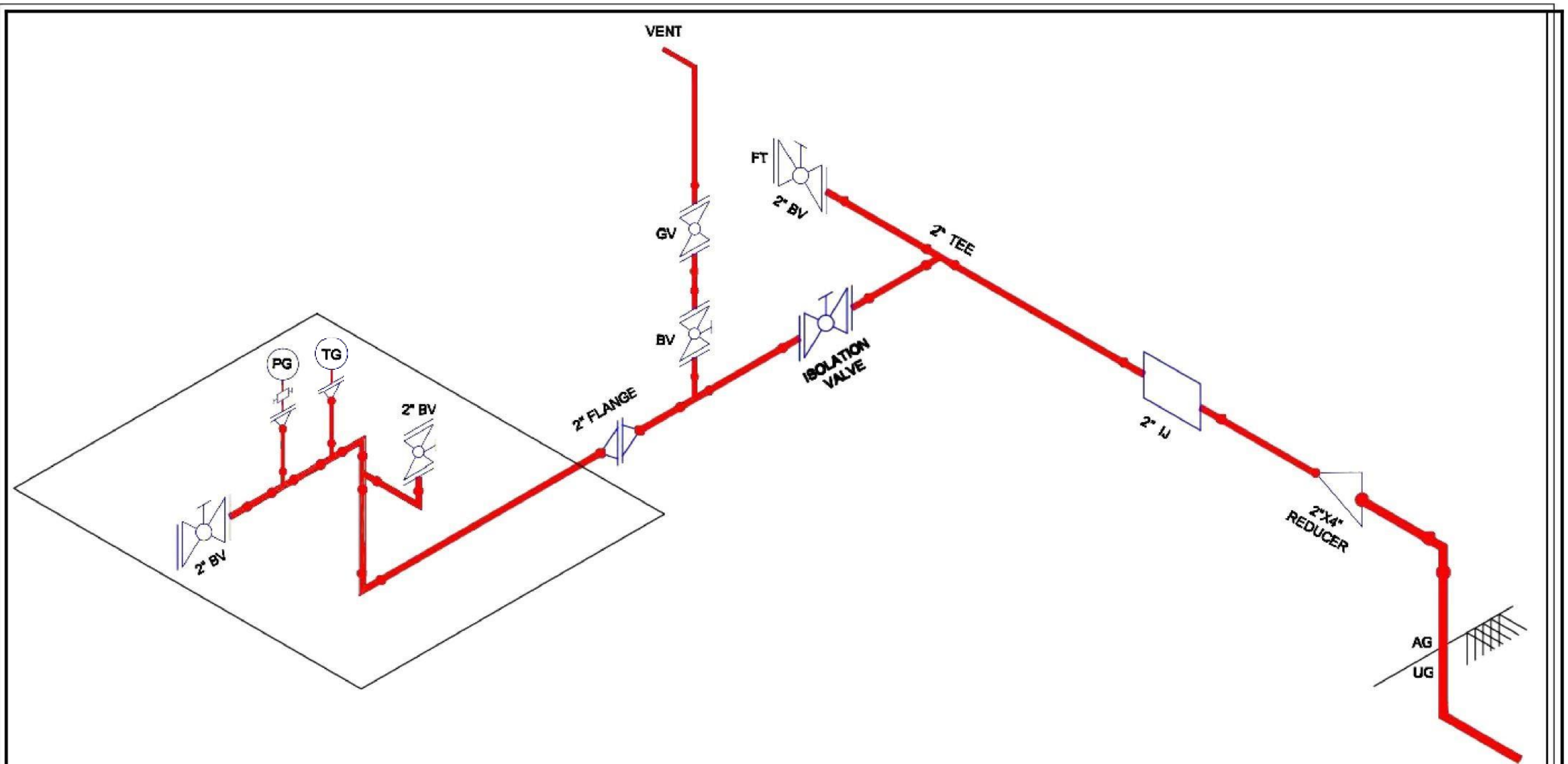

% AR DRS CONNECTIVITY

	Prepared By	Checked By	Approved By
SIGNATURE			
NAME	Subrat Biswal.	Pala Varu / Rohit Amin	D.S. Durgesh.
DATE :-	12/08/2014		
CLIENT	 Sabarmati Gas Ltd.		
TITLE:	IDAR DRS INLET CCNNECTIVITY		
LOCATION:	IDAR, SABARKANTHA		
SCALE	Sheet	DRAWING NO.	SIZE REV.
NOS.	1 OF 1	SGL/DRS CONNECTIVITY/IDAR-01	A3 00

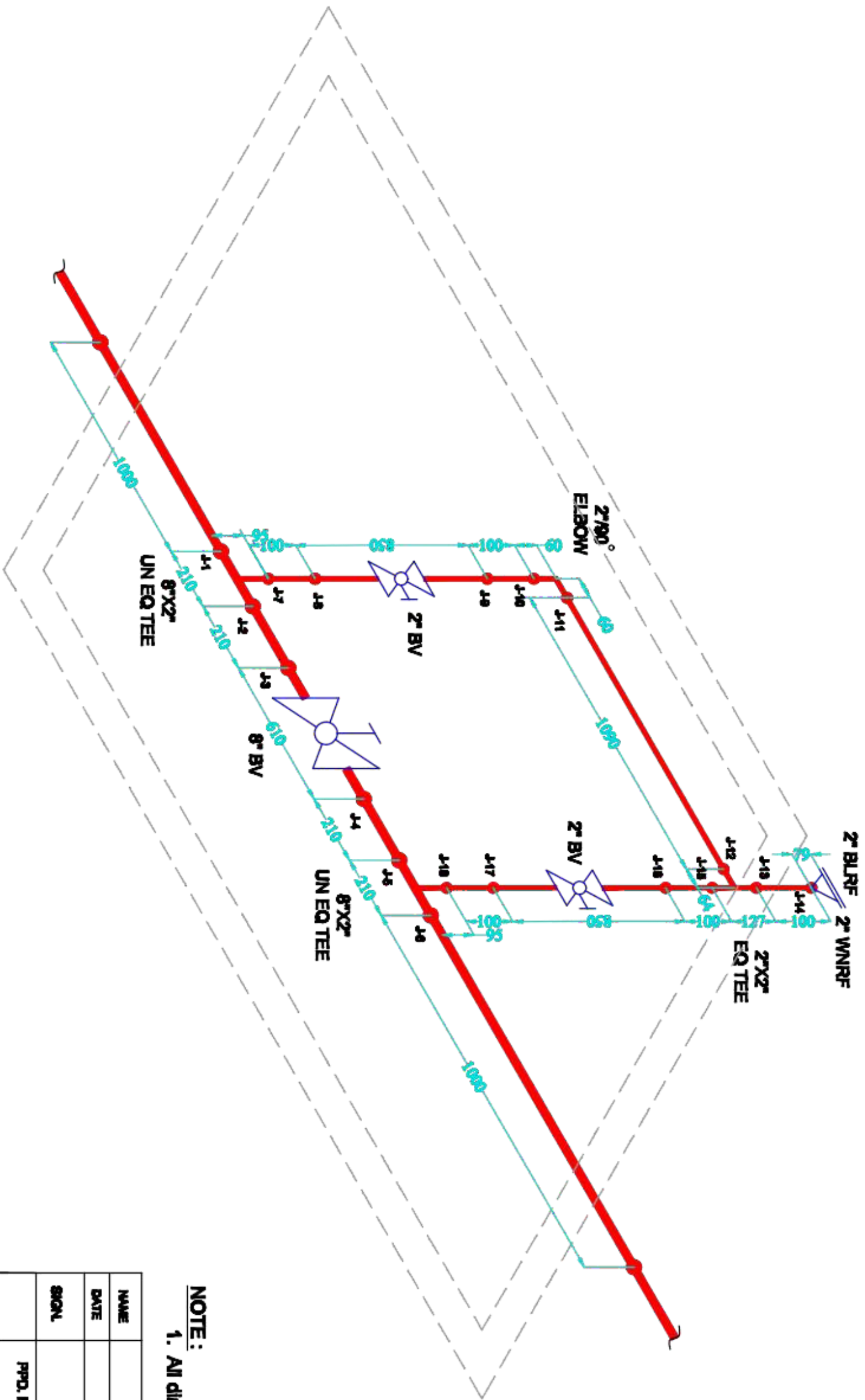

- LEGEND**
- 8" STEEL PIPE
 - 2" STEEL PIPE

BILL OF MATERIAL

SR.NO.	DESCRIPTION	SIZE	SPECIFICATION	UOM	QTY.
1.	PIPE	4"	API 5L PSL 20-X-52 ASTM A106 GR.B SCH.80	MTR.	2.42
2.	PIPE	2"	ASTM A106 GR.B SCH.80	MTR.	1.59
3.	90° ELBOW	2"	ASTM A234 WPB SCH.80	Nos.	01
4.	BALL VALVE	4"	300#, BODY: WCB (BW)	Nos.	02
5.	BALL VALVE	2"	300#, BODY: WCB (BW)	Nos.	02
6.	EQ TEE	2" X 2"	ASTM A234 WPB SCH.80	Nos.	01
7.	UN EQ TEE	4" X 2"	ASTM A234 WPB SCH.80	Nos.	02
8.	WNR FLANGE	2"	300#, ASTM A105 SCH.80	Nos.	01
9.	BLRF FLANGE	2"	300#, ASTM A105	Nos.	01
10.	GASKET SPRING WOUND	2"	300#	Nos.	01
11.	STUD & NUTS	2"	5/8" X 4"	Nos.	08

NOTE:
1. All dimension are in mm.

NAME				
DATE				
SIGN.				
PPD. BY	CHKD. BY	REVM. BY	APPD. BY	

CLIENT:
Sabarmati Gas Ltd.
 (A Joint Venture of GSPC & BPCIL)

PROJECT:

TRNA:

CONTRACTOR:

TITLE:
PURPOSE DRAWING FOR IV-01

SR.NO.	DESCRIPTION	SIZE	SPECIFICATION	UOM	QTY.
1.	PIPE	4"	API 5L PSL 20-X-52 ASTM A106 GR.B SCH.80	MTR.	2.42
2.	PIPE	2"	ASTM A106 GR.B SCH.80	MTR.	1.59
3.	90° ELBOW	2"	ASTM A234 WPB SCH.80	Nos.	01
4.	BALL VALVE	4"	300#, BODY: WCB (BW)	Nos.	02
5.	BALL VALVE	2"	300#, BODY: WCB (BW)	Nos.	02
6.	EQ TEE	2" X 2"	ASTM A234 WPB SCH.80	Nos.	01
7.	UN EQ TEE	4" X 2"	ASTM A234 WPB SCH.80	Nos.	02
8.	WNR FLANGE	2"	300#, ASTM A105 SCH.80	Nos.	01
9.	BLRF FLANGE	2"	300#, ASTM A105	Nos.	01
10.	GASKET SPRING WOUND	2"	300#	Nos.	01
11.	STUD & NUTS	2"	5/8" X 4"	Nos.	08

SCALE	SHEET	DRAWING NO.	SIZE	REV
NTS	01 OF 01		A3	00

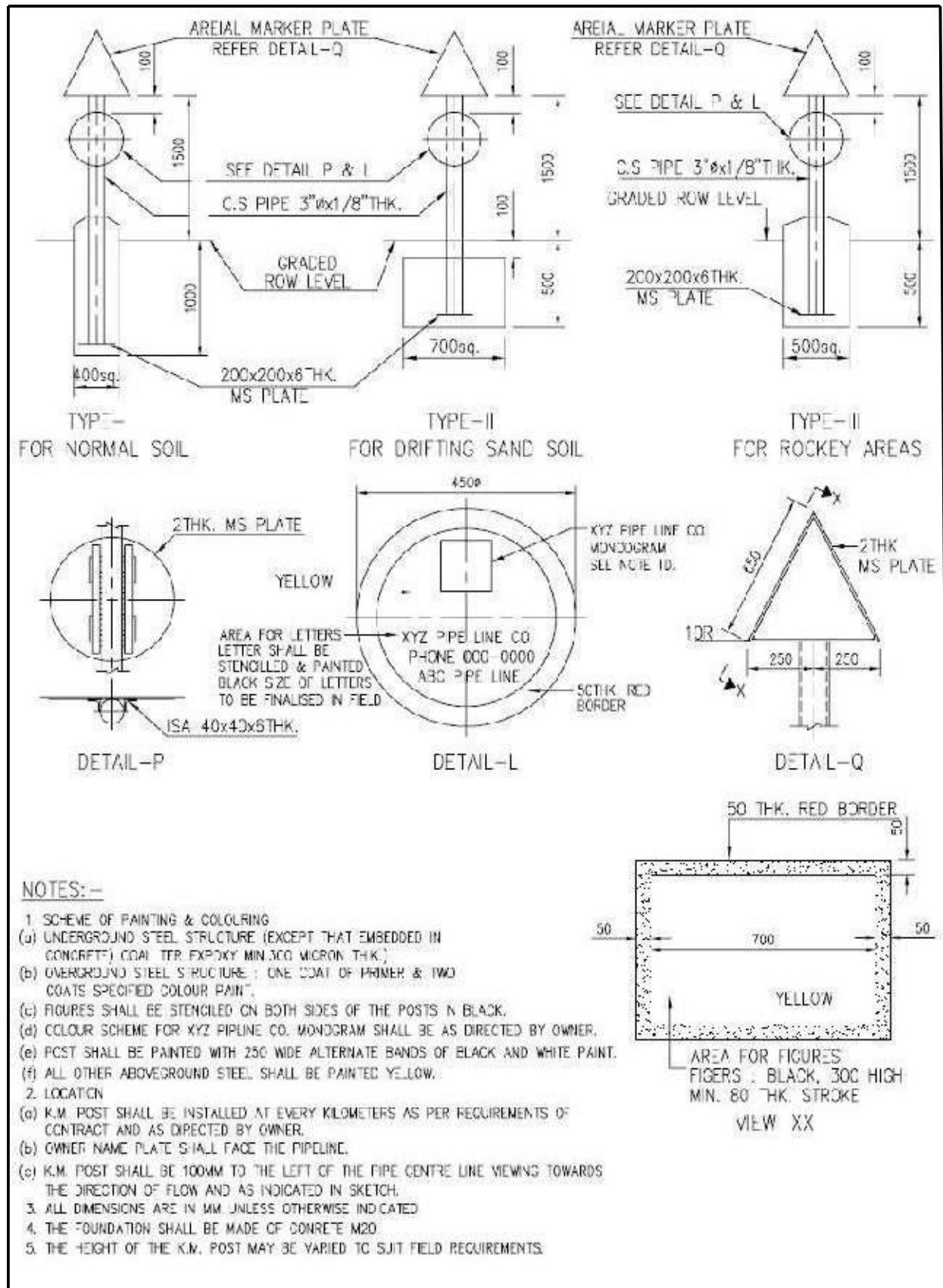

A

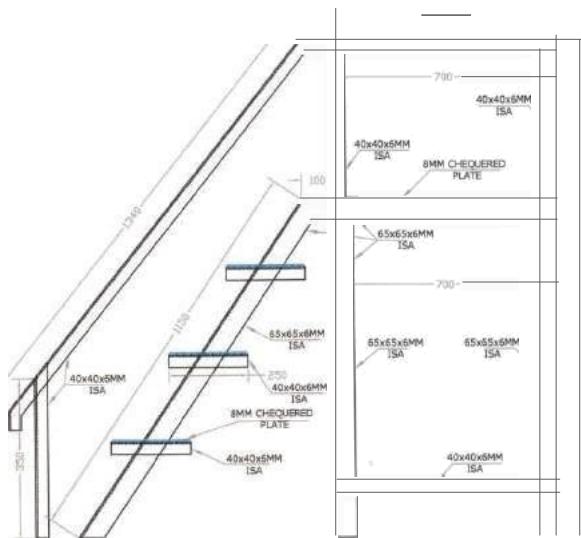

ELEVATION

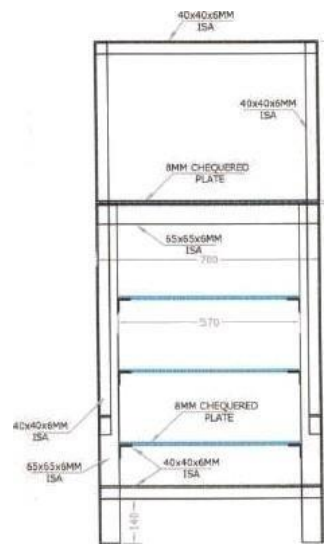

SECTION A-A

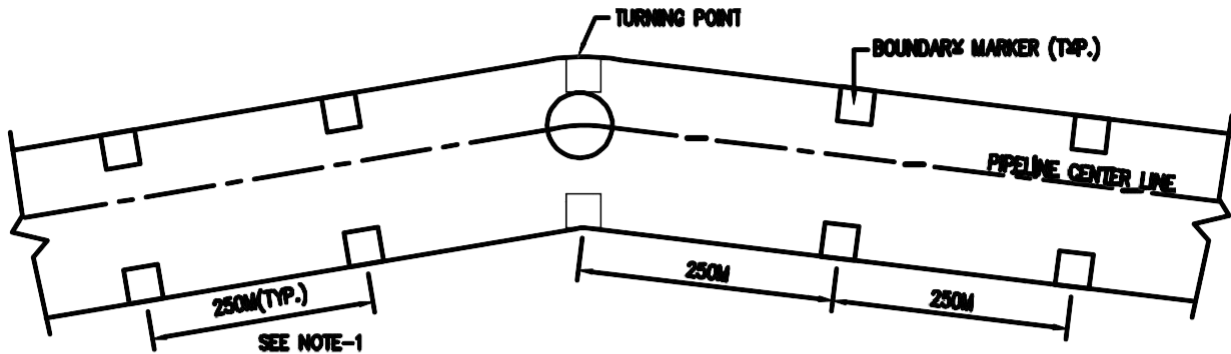

LOCATION PLAN OF BOUNDARY MARKER

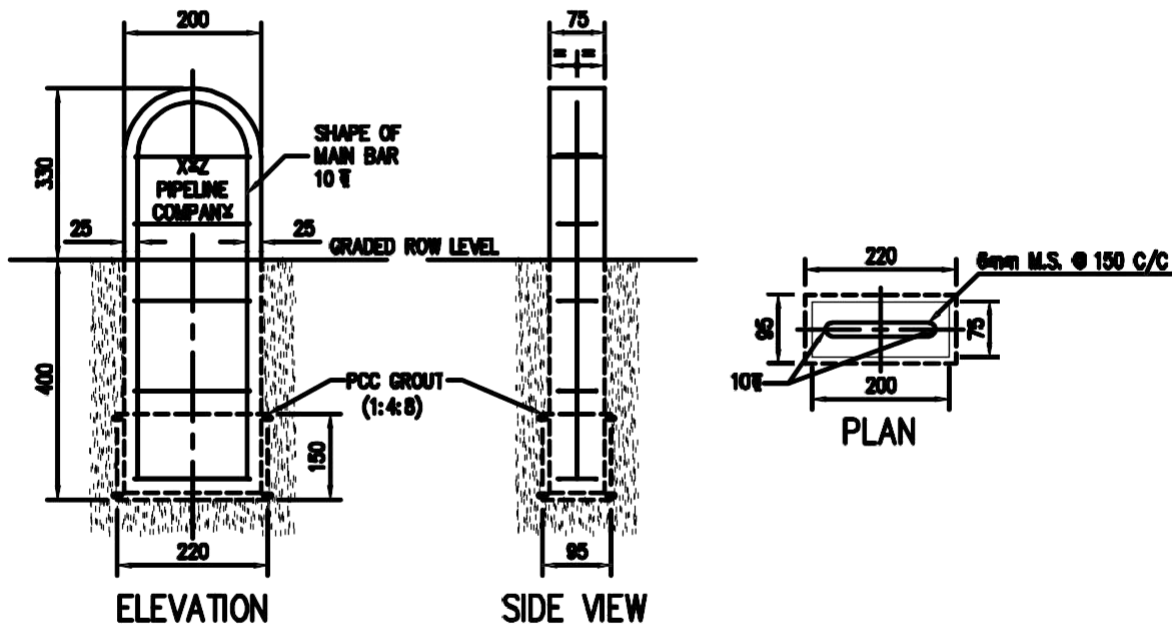

NOTES: -

1. ALL DIMENSIONS ARE IN MM UNLESS OTHERWISE STATED.
2. BOUNDARY MARKERS SHALL BE INSTALLED AT THE ROW LIMITS ON EITHER SIDE AT 250M CENTERS AND ALSO AT ALL TURNING POINTS AS PER SPECIFICATIONS AND AS DIRECTED BY OWNER. BOUNDARY MARKERS SHALL PREFERABLY BE PLACED ON FIELD BUNDS/ UNCULTIVABLE AREAS.
3. ALL BOUNDARY MARKERS SHALL BE PRECAST AND INSCRIPTIONS SHALL BE ENGRAVED CENTRALLY IN THE MOULD ON THE FACE.
4. LETTERS SHALL BE 60 HIGH AND 5 DEEP.
5. INSCRIPTIONS SHALL FACE THE PIPE LINE.
6. CONCRETE FOR BOUNDARY MARKERS SHALL BE M20.
7. ABOVE GROUND PART OF BOUNDARY MARKERS SHALL BE PAINTED YELLOW WITH MIN. THREE COATS OF APPROVED QUALITY PAINT. INSCRIPTIONS SHALL BE PAINTED BLACK.

0	30.12.05		R.M.A.	P.S.	S.M.
REV. NO.	DATE	SUBJECT OF REVISION	DRAWN	CHECKED	APPROVED

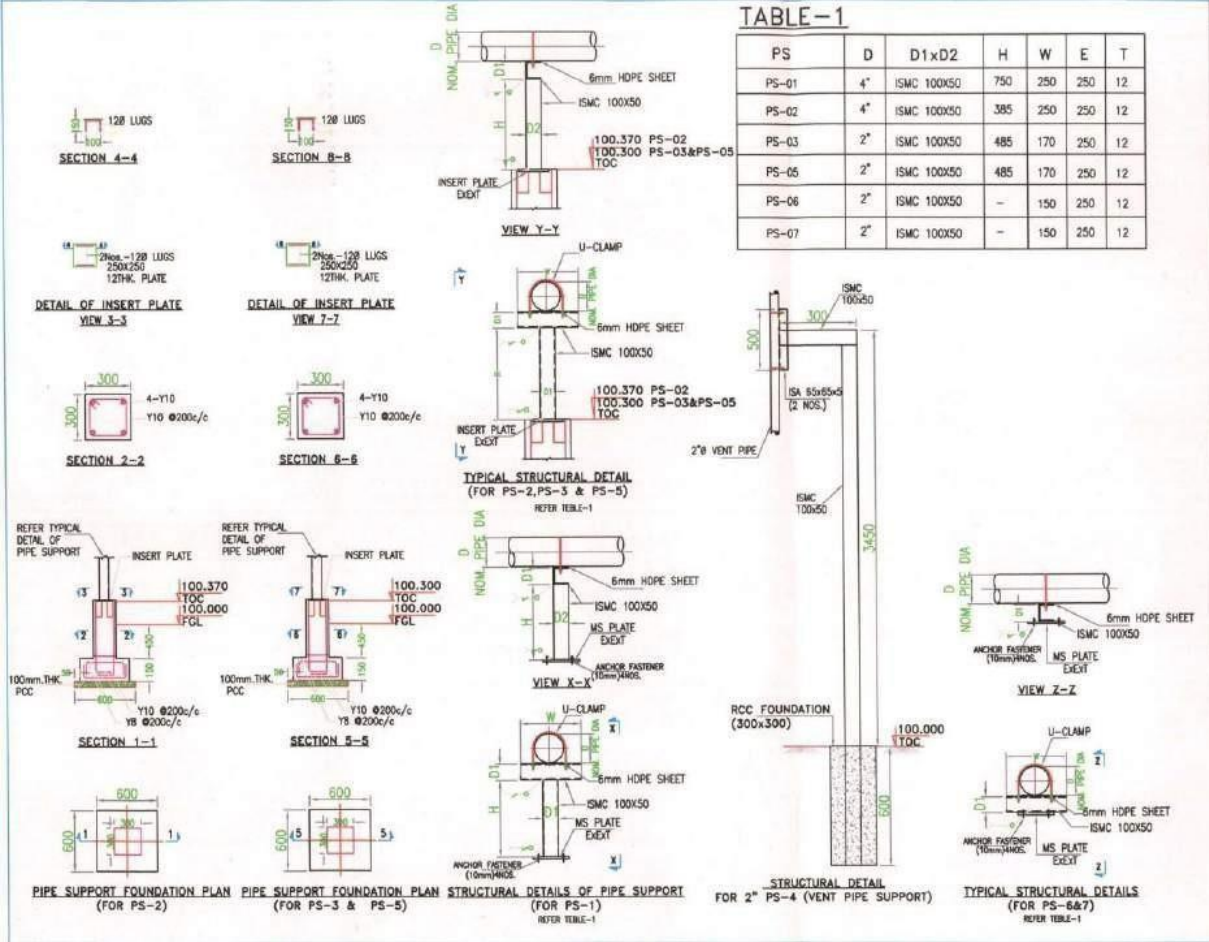



Sabarmati Gas Ltd.

PIR UNE fiARNIN6 9QI

DRAWING NO.

3PKT-STD-P-&114

SHEET No.

1 so 1

**WPE-I
FOR NORU6 SOL**

F6 DRIFTING SAND SOL

FOR RfX?KY AREAS



WARNING
ABC PIPELINE

DETdL-A

MNNGOETAI

3. LOCATION

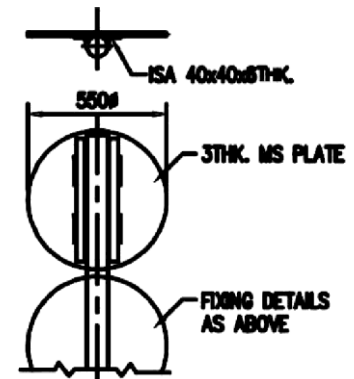
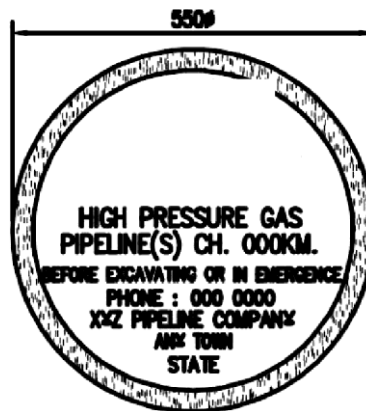
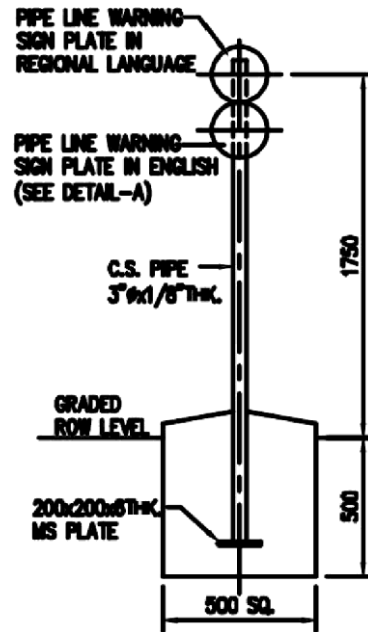
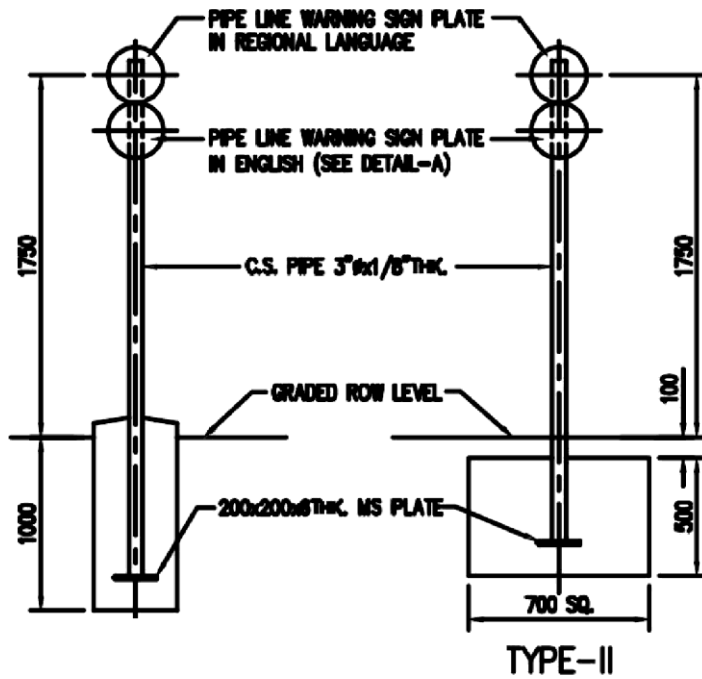
o	W1ZJ@		R.EA.	PS.	SM
REV, Ng,	DATE	SUBJECT OF REVISION	DRAWN	CHECKED	APPROVED



WARNING SIGN PLATE

SHALL BE INSTALLED TO THE LEFT OF THE PIPE CENTER LINE, VIEWING IN THE DIRECTION OF FLOW AT 300MM FROM PIPELINE O.D. AND THE WARNING SIGN PLATE SHALL FACE THE UTILITY BEING CROSSED.



Sabarmati Gas Ltd.



(A Joint Venture of GSPC and BPCL)

SABARMATI GAS LIMITED

**LAYING, INSTALLATION, TESTING AND COMMISSIONING OF
8" DIA. STEEL GAS PIPELINE CONNECTIVITY IN PATAN GA**



RESONANCE ENERGY PVT. LTD.

**Specification of Civil Work
Tender No. REPL/SGL/STPL/009/22**

	LAYING, INSTALLATION, TESTING AND COMMISSIONING OF 8" DIA. STEEL GAS PIPELINE CONNECTIVITY IN PATAN GA	
TENDER DOCUMENT NO REPL/SGL/STPL/009/22		Date: -28/11/2022

SPECIFICATION FOR CIVIL WORKS

PART – I MATERIALS

	LAYING, INSTALLATION, TESTING AND COMMISSIONING OF 8" DIA. STEEL GAS PIPELINE CONNECTIVITY IN PATAN GA	
TENDER DOCUMENT NO REPL/SGL/STPL/009/22		Date: -28/11/2022

C O N T E N T S

1.0 GENERAL



- 1.1 Scope
- 1.2 Standard
- 1.3 Approval and Tests
- 1.4 Codes
- 1.5 Rejection of Materials

2.0 MATERIALS FOR CONCRETE

- 2.1 Aggregates
- 2.2 Coarse Aggregates
- 2.3 Fine Aggregates
- 2.4 Lime
- 2.5 Surkhi
- 2.6 Cement
- 2.7 Water
- 2.8 Admixtures for Concrete
- 2.9 Interval of Routine Test

3.0 STEEL

- 3.1 For Reinforcement
- 3.2 For Binding Works
- 3.3 For Light Structural Work and Insert

	LAYING, INSTALLATION, TESTING AND COMMISSIONING OF 8" DIA. STEEL GAS PIPELINE CONNECTIVITY IN PATAN GA	
TENDER DOCUMENT NO REPL/SGL/STPL/009/22		Date: -28/11/2022



- 3.4 Steel Tubes
- 3.5 Foundation Bolts
- 3.6 Steel tubes for Non-structural use
- 3.7 Threaded Fasteners
- 3.8 Testing
- 3.9 Cast Steel
- 3.10 Conduits

4.0 ASBESTOS CEMENT PRODUCTS

- 4.1 General
- 4.2 Building Boards
- 4.3 Flat Sheets
- 4.4 Pipes and Fittings
- 4.5 Corrugated and Semi-corrugated sheets
- 4.6 Asbestos Cement Roof fittings

5.0 BRICK AND STONES

- 5.1 Bricks
- 5.2 Handling
- 5.3 Inspection
- 5.4 Brick Bats
- 5.5 Laterite Stone Blocks
- 5.6 Stones (Granite, trap, sandstone and quartzite etc.)

	LAYING, INSTALLATION, TESTING AND COMMISSIONING OF 8" DIA. STEEL GAS PIPELINE CONNECTIVITY IN PATAN GA	
TENDER DOCUMENT NO REPL/SGL/STPL/009/22		Date: -28/11/2022

5.7 Hollow and Solid Concrete Blocks

5.8 Cement, Lime and Water

5.9 Sand for Masonry Mortar

6.0 SAND FOR PLASTERING

7.0 MATERIALS FOR FLOORING & PAVING

7.1 Cement & Binders

7.2 Aggregates

7.3 Tiles

7.4 Pigments

7.5 Red oxide of Iron

7.6 Hardening Agents

7.7 Dividing Strips

7.8 Marble chips

7.9 Marble powder

8.0 TIMBER



8.1 General

8.2 Teak Wood / Sal / Beja Sal / Deodar / Kail and other varieties.

8.3 Storage & Inspection

8.4 Moisture Content

8.5 Allowance for Bulk Timber

	LAYING, INSTALLATION, TESTING AND COMMISSIONING OF 8" DIA. STEEL GAS PIPELINE CONNECTIVITY IN PATAN GA	
TENDER DOCUMENT NO REPL/SGL/STPL/009/22		Date: -28/11/2022

8.6 Flush Door Shutters, Shelves

8.7 Wood Particle Board

8.8 Veneered Particle Board

8.9 Plywood for general purpose

8.10 Veneered decorative plywood

9.0 FITTINGS FOR DOORS, WINDOWS ETC.

9.1 General

9.2 Hinges

9.3 Sliding Door Bolts

9.4 Door Rim Latch

9.5 Tower bolts

9.6 Door Handles

9.7 Mortice locks and Rebated Mortice locks

9.8 Floor door stopper

9.9 Hooks and eyes.

9.10 Casement window handles

9.11 Casement peg stays



9.12 Quadrant stays

9.13 Fan light pivots

9.14 Fan light catch

9.15 Steel Frames for doors

9.16 Putty

	LAYING, INSTALLATION, TESTING AND COMMISSIONING OF 8" DIA. STEEL GAS PIPELINE CONNECTIVITY IN PATAN GA	
TENDER DOCUMENT NO REPL/SGL/STPL/009/22		Date: -28/11/2022

10.0 METAL DOORS, WINDOWS, VENTILATORS AND ROLLING SHUTTERS



- 10.1 General
- 10.2 Steel doors, Windows, Ventilators
- 10.3 Aluminium Doors, Windows, Ventilators
- 10.4 Steel Rolling Shutter, Rolling Grills
- 10.5 M.S. Bolts etc.,
- 10.6 Hardware
- 10.7 Mastic

11.0 GLASS

- 11.1 General
- 11.2 Plain Transparent Glass
- 11.3 Ground or Frosted Glass
- 11.4 Thickness
- 11.5 Inspection

12.0 PAINT



- 12.1 General
- 12.2 Sampling & Testing
- 12.3 Storage
- 12.4 Paints for Priming
- 12.5 Paints for Finishing

	LAYING, INSTALLATION, TESTING AND COMMISSIONING OF 8" DIA. STEEL GAS PIPELINE CONNECTIVITY IN PATAN GA	
TENDER DOCUMENT NO REPL/SGL/STPL/009/22		Date: -28/11/2022

- 12.6 White Wash
- 12.7 Colour Wash
- 12.8 Water proof cement Paint
- 12.9 Distemper
- 12.10 Varnish
- 12.11 Polish
- 12.12 Plastic acrylic emulsion paint
- 12.13 Creosote oil or Coal tar creosote
- 12.14 Coal Tar black paint
- 12.15 Floor polish paste

13.0 WATERPROOFING MATERIALS

- 13.1 Integral Cement water proofing compounds
- 13.2 Bitumen
- 13.3 Bitumen Primer
- 13.4 Bitumen Felt
- 13.5 Bitumen Mastic
- 13.6 Bituminous Compounds
- 13.7 Surface Application Materials
- 13.8 Polymer based paints
- 13.9 Fibre glass R.P. Tissue
- 13.10 P.V.C. Membrane/sheet

	LAYING, INSTALLATION, TESTING AND COMMISSIONING OF 8" DIA. STEEL GAS PIPELINE CONNECTIVITY IN PATAN GA	
TENDER DOCUMENT NO REPL/SGL/STPL/009/22		Date: -28/11/2022

14.0 WATER BAR

14.1 General

14.2 Jointing

15.0 LEAD

15.1 General

16.0 BUILDING PAPER/GYPSUM MATERIALS

16.1 Building paper

17.0 FILLING MATERIAL

17.1 General

17.2 Mastic Bitumen

17.3 Flexible Boards

18.0 DRAINAGE AND SANITATION (INTERNAL)

18.1 General

18.2 P.V.C Waste Pipe

18.3 Stoneware Pipes

18.4 HCl Pipes and fittings



18.5 Cast Iron Pipes and AC pipes (Rain Water pipes)

18.6 Sanitary appliances (E.W.C. & I.W.C.)

18.7 Wash Hand Basin

18.8 Flat Back Lipped Urinal

18.9 Mirror Frames



	LAYING, INSTALLATION, TESTING AND COMMISSIONING OF 8" DIA. STEEL GAS PIPELINE CONNECTIVITY IN PATAN GA	
TENDER DOCUMENT NO REPL/SGL/STPL/009/22		Date: -06/12/2022

- 18.10 Toilet Shelf
- 18.11 Towel rail
- 18.12 Soap Container
- 18.13 CP Flush Valves for E.W.C.
- 18.14 CP Flush Valves for urinals
- 18.15 Gully Trap
- 18.16 C.I. Manhole Cover and frame
- 18.17 Flushing cistern
- 18.18 Plastic seat & cover for water closets

19.0 WATER SUPPLY & PLUMBING (INTERNAL)

- 19.1 General
- 19.2 G.I. Pipes and Fittings
- 19.3 RCC, Asbestos, prestressed pipes and fittings
- 19.4 C.I. Pipes and fittings
- 19.5 Steel Pipes
- 19.6 Bib Tap and Stop Tap
- 19.7 Valves
- 19.8 Shower Rose
- 19.9 Storage Tank
- 19.10 Misc. items

20.0 EXTERNAL SEWERAGE & DRAINAGE

	LAYING, INSTALLATION, TESTING AND COMMISSIONING OF 8" DIA. STEEL GAS PIPELINE CONNECTIVITY IN PATAN GA	
TENDER DOCUMENT NO REPL/SGL/STPL/009/22		Date: -28/11/2022



- 20.1 C.I. Pipes
- 20.2 Washers
- 20.3 Gaskets
- 20.4 Caulking Lead
- 20.5 Salt glazed stoneware Pipes
- 20.6 Steel pipes
- 20.7 Cast Iron Manhole Covers and frames

21.0 ROAD AND FENCING

- 21.1 General
- 21.2 Soling Stones
- 21.3 Coarse aggregate for Water Bound Macadam
- 21.4 Screenings
- 21.5 Stone Chips for Bituminous Surfacing
- 21.6 Sand
- 21.7 Binder
- 21.8 Kerbs
- 21.9 Barbed wire
- 21.10 Chain link fabric
- 21.11 Concertina Coil fencing

22.0 APPROVED BRAND AND/OR MANUFACTURER'S NAME FOR SOME OF THE IMPORTANT MATERIALS

23.0 MATERIALS NOT SPECIFIED

	LAYING, INSTALLATION, TESTING AND COMMISSIONING OF 8" DIA. STEEL GAS PIPELINE CONNECTIVITY IN PATAN GA	
TENDER DOCUMENT NO REPL/SGL/STPL/009/22		Date: -28/11/2022

1.0 GENERAL

1.1 Scope

This part deals with the requirements of materials for use in construction work with regard to quality, testing, approval and storage, before they are used on work. This part is supplementary to Part-II: Workmanship and Other requirements of the Technical Specifications for civil works.

1.2 Standard



A high standard of quality is required for all materials used in construction work. They shall be the best of the kind obtainable indigenously in each case and shall be procured from manufacturers of repute in order to ensure uniformity of quality and assurance of timely supply.

1.3 Approval and Tests

1.3.1 All materials to be used in construction shall be subject to approval of the Engineer. The Contractor shall apply sufficiently in advance with samples of the materials including the supporting test results from the approved laboratory and other documentary evidence from the manufacturer wherever applicable and indicating the types of materials and their respective sources. The delivery of materials at site shall commence only after the approval of the quality, grading and sources of the materials by the Engineer.

1.3.2 The quality of all materials once approved shall be maintained throughout the period of construction and periodical tests shall be carried out to ensure that it is maintained. Such routine tests shall be listed under the different materials and/or as may be ordered by the Engineer from time to time.

1.3.3 Where a particular "Brand" or "Make" of material is specified in the Schedule of Items or Technical Specifications, such "Brand" or "Make" of material alone shall be used on the work. Should it become necessary for any reason (such as non-availability/ceased to be produced), to use any material other than the specified "Brand" or "Make", the Contractor shall submit sample of the same to the Engineer for approval together with test certificates and other documents necessary for examining and giving approval thereof.

	LAYING, INSTALLATION, TESTING AND COMMISSIONING OF 8” DIA. STEEL GAS PIPELINE CONNECTIVITY IN PATAN GA	
TENDER DOCUMENT NO REPL/SGL/STPL/009/22		Date: -28/11/2022

Should such change or substitution of materials, subsequently approved, results in use of material of price lower than that of the material specified in the Schedule of Items or Technical Specifications, the rates of work affected by the substitution shall be proportionately reduced. Similarly, in case the substitution results in use of material of price higher than that specified in the Schedule of Items or Technical Specifications, the rates of work affected by the substitution shall be proportionately increased.

1.4 Codes

- 1.4.1 The years of publication against various standards, referred in this specification, correspond to the latest standards as on date of preparation of this specification. During use of this specification in future, the latest publication as on date shall be referred to. Where standards are not yet published by the BIS or IRC, adoptable British Standards or other International Standards shall apply.
- 1.4.2 In case of any conflict in meaning between these specifications and those of BIS or IRC, or British /International Standard; the provisions of these specifications shall prevail.



1.5 Rejection of Materials

- 1.5.1 Any material brought to site which, in the opinion of the Engineer is damaged, contaminated, deteriorated or does not comply with the requirement of this specification shall be rejected.
- 1.5.2 If the routine tests or random site tests show that any of the materials, brought to site, do not comply in any way with the requirements of this specification or of I.S. Codes as applicable, then that material shall be rejected.
- 1.5.3 The Contractor at his own cost shall remove from site any and all such rejected material within the time specified by the Engineer.

2.0 MATERIALS FOR CONCRETE

2.1 Aggregates

- 2.1.1 Aggregates shall comply with the requirements of IS: 383-1970 "Coarse and Fine Aggregates for Concrete". They shall be hard,

	LAYING, INSTALLATION, TESTING AND COMMISSIONING OF 8" DIA. STEEL GAS PIPELINE CONNECTIVITY IN PATAN GA	
TENDER DOCUMENT NO REPL/SGL/STPL/009/22		Date: -28/11/2022

strong, dense, durable, clean and free from veins and adherent coating, vegetable matter and other deleterious substances; and shall be obtained from approved sources. Aggregates shall not contain any harmful material such as pyrites, coal, lignite, shale or similar laminated material, clay, alkali, soft fragments, sea shells and organic impurities in such quantity as to affect the strength or durability of concrete. Aggregates which are chemically reactive with alkalies of cement shall not be used. Aggregates which are not sufficiently clean shall be washed in clean fresh water to the satisfaction of the Engineer.

2.1.2 Testing

All aggregates shall be subject to inspection and testing. The Contractor shall submit samples for testing as may be required by the Engineer. Sampling and testing shall be carried out in accordance with IS: 2386-1963 "Methods of Test for Aggregates for concrete".

2.1.3 Grading



The Contractor shall ensure that the full range of aggregate used for making concrete is graded in such a way as to ensure a dense workable mix. The delivery of aggregates will commence only when the Engineer has approved the samples and the quality and grade shall be maintained consistent and equal to the approved sample. Before construction commences, the Contractor shall carry out a series of tests on the aggregates and on the concrete made therefrom to determine the most suitable grading of the available aggregates. Once the most suitable grading has been found, the grading shall be adopted for the construction of the works and periodic tests shall be carried out to ensure that it is maintained.

2.1.3.1 Size and grading of fine aggregates

The grading shall conform to IS: 383-1970 and shall be within the limits of Grading Zone-III. The maximum size of particle shall be 4.75mm and shall be graded down. Sand containing more than 10% of fine grains passing through 150 micron sieve or having the fineness modulus less than 2 shall not be used for concrete work.

2.1.3.2 Size and grading of coarse aggregates

The nominal maximum size of the aggregates for each mark of concrete or for each type of work shall depend upon the description of

	LAYING, INSTALLATION, TESTING AND COMMISSIONING OF 8” DIA. STEEL GAS PIPELINE CONNECTIVITY IN PATAN GA	
TENDER DOCUMENT NO REPL/SGL/STPL/009/22		Date: -28/11/2022

the particular item in the Schedule of Items and/or according to relevant clauses of IS: 456-1978. The aggregates shall be wellgraded and the grading shall conform to relevant requirements of IS: 383-1970 depending upon the maximum nominal size as specified or as required.

2.1.3.3 Fine aggregate for mortar and grout

The grading of fine aggregate for mortar and grout shall be within the limits of grading zone III and IV as defined in IS: 383-1970.

2.1.4 Storage & stacking

Care shall be taken in the storage to avoid intrusion of any foreign materials into the aggregates and where two types of aggregates are stored close to each other, they shall be separated by a wall or plate. In case of stockpiling, care shall be taken to avoid forming pyramids resulting in segregation of different sized materials. The height of the stacks shall be generally limited to 150 cm.

2.2 Coarse Aggregates

2.2.1 Types



The type of coarse aggregate viz., stone chips, gravel or broken brick shall be as described in the Schedule of Items. Unless otherwise specified in the Schedule of Items, stone chips shall be used as coarse aggregate.

2.2.2 Stone chips

It shall be crushed or broken from hard stone obtained from approved quarries of igneous or metamorphic origin. The stone chips shall be hard, strong, dense, durable and angular in shape. It shall be free from soft, friable, thin, flat, elongated or laminated and flaky pieces and free from dirt, clay lumps, and other deleterious materials like coal, lignites, silt, soft fragments, and other foreign materials which may affect adversely the strength & durability of concrete. The total amount of deleterious /foreign materials shall not exceed 5% by weight according to relevant clause of IS: 383-1970. If found necessary the stone chips shall be screened and washed before use.

2.2.3 Gravel

It can be either river bed shingle or pit gravel. It shall be sound, hard,

	LAYING, INSTALLATION, TESTING AND COMMISSIONING OF 8" DIA. STEEL GAS PIPELINE CONNECTIVITY IN PATAN GA	
TENDER DOCUMENT NO REPL/SGL/STPL/009/22		Date: -28/11/2022

clean, irregular in shape and suitably graded in size with or without some broken fragments. It shall be free from flat particles, powdered clay, silt, loam and other impurities. Before using, the gravel shall be screened and washed to the satisfaction of the Engineer. However, the foreign/deleterious materials shall not exceed 5% by weight.

2.2.4 Broken bricks / Brick aggregates

These shall be obtained by breaking well burnt or over burnt dense brick bats. They shall be homogeneous in texture, well graded in size, roughly cubical in shape, clean and free from dirt, clay, silt or any other deleterious matter. Before use, these shall be screened.

2.3 Fine Aggregates

2.3.1 Unless specified otherwise it shall either be natural river sand or pit sand.

2.3.2 Sand shall be clean, sharp, strong, angular and composed of hard siliceous material. It shall not contain harmful organic impurities in such form or quantities as to affect adversely the strength and durability of concrete. Sand for reinforced concrete shall not contain any acidic or other impurities which is likely to attack steel reinforcement. The percentage of all deleterious materials including silt, clay etc., shall not exceed 5% by weight. If directed, sand shall be screened or washed before use to the satisfaction of Engineer.



2.3.3 Crusher dust

Crusher stone dust (that is retained on 300 micron sieve) may be used as replacement for certain quantum of sand aiming to improve the fineness modulus of fine aggregate. The quantum of replacement for sand shall be arrived at by suitable trial mixes. The Engineer will decide the final usage of crusher dust depending on the circumstances.

2.4 Lime

Lime for mortars and concrete shall conform to IS: 712-1984 The total of CaO and MgO content in quick lime shall not be less than 85% (MgO shall not exceed 5%). Quicklime, after slaking, shall leave a residue of not more than 5% by weight on IS sieve 85.

2.5 Surkhi

	LAYING, INSTALLATION, TESTING AND COMMISSIONING OF 8” DIA. STEEL GAS PIPELINE CONNECTIVITY IN PATAN GA	
TENDER DOCUMENT NO REPL/SGL/STPL/009/22		Date: -28/11/2022

Surkhi used in lime concrete for flooring, terracing etc., shall conform to IS: 3182-1986. Surkhi shall be made from well burnt bricks or brickbats. Surkhi shall pass through I.S. sieve 3.35mm with at least 50 % of it passing through I.S. sieve 1.70mm and be perfectly clean and free from foreign matter. Surkhi shall not be made from bricks which have come in contact with any mortar.

2.6 Cement



Ordinary Portland cement / Portland slag cement complying with the requirements of IS:269-1989 and I.S. 455-1989 respectively shall be used for making plain and reinforced concrete, cement grout and mortar.

Other types of cement may be used depending upon the requirements of certain jobs with the approval of the Engineer. These shall conform to the following standards :

Portland Pozzolana Cement	IS: 1489-1991
Rapid Hardening Portland Cement	IS: 8041-1990
43 Grade Ordinary Portland Cement	IS: 8112-1989
53 Grade Ordinary Portland Cement	IS: 12269-1987
Hydrophobic Portland Cement ..	IS: 8043-1991
High alumina cement for structural work	IS: 6452-1989
White portland cement	IS: 8043-1989
Sulphate Resisting Portland Cement	IS: 12330-1988

2.6.1 Testing of samples

The Contractor shall supply a copy of the manufacturer's test certificate for each consignment of cement supplied by him and consignments shall be used on work in the order of delivery. The Contractor shall supply samples of cement to the Engineer as frequently as he may require for testing. The sampling of cement for testing shall be according to IS: 3535-1986. All tests shall be in accordance with the

	LAYING, INSTALLATION, TESTING AND COMMISSIONING OF 8” DIA. STEEL GAS PIPELINE CONNECTIVITY IN PATAN GA	
TENDER DOCUMENT NO REPL/SGL/STPL/009/22		Date: -28/11/2022

relevant clauses of IS: 4031 (Part-I to Part-15) 1988 to 1991 & IS: 4032-1985.

2.6.2 Contractor's responsibility

From the time a consignment of cement is delivered at site and tested and approved by the Engineer until such time as the cement is used on the works, the Contractor shall be responsible for keeping the same in sound and acceptable condition and at his expense and risk. Any cement which deteriorates while in the Contractor's charge and is rejected as unsuitable by the Engineer, shall be removed from the site to outside the limits of work at the cost of contractor within two days of ordering such removal by the Engineer.

2.6.3 Stock of cement

In order to ensure due progress, the Contractor shall at all times maintain on the site at least such stock of cement as the Engineer may from time to time consider necessary. No cement shall be used upon the works until it has been accepted as satisfactory by the Engineer.



2.6.4 Storage of cement

The cement shall be stored in such manner as to permit easy access for proper inspection and in a suitable weather-tight, well ventilated building to protect it from dampness caused by ingress of moisture from any source. Different types of cement shall be stored separately. Cement bags shall be stacked at least 15 to 20 cm clear of the floor leaving a space of 60 cm around the exterior walls. The cement shall not be stacked more than 10 bags high. Each consignment of cement shall be stacked separately to permit easy access for inspection.

2.7 Water

Water used for mixing concrete and mortar and for curing shall be clean and free from injurious amounts of oil, acid, alkali, salts, sugar, organic materials or other substances that may be deleterious to concrete or steel. The pH value of water shall generally be not less than '6'. Water has to meet the requirements mentioned in clause 4.3 of IS: 456-1978. Water shall be obtained from an approved source.

Where it is obtained from a source other than a supply main, it shall be

	LAYING, INSTALLATION, TESTING AND COMMISSIONING OF 8” DIA. STEEL GAS PIPELINE CONNECTIVITY IN PATAN GA	
TENDER DOCUMENT NO REPL/SGL/STPL/009/22		Date: -28/11/2022

tested to establish its suitability. Water for construction purpose shall be stored in proper storage tanks to prevent any organic impurities getting mixed up with it.

2.8 Admixture for Concrete

2.8.1 Approval

Admixtures to concrete shall not be used without the written consent of the Engineer. When permitted, the Contractor shall furnish full details from the manufacturer and shall carry out such test as the Engineer may require before any admixture is used in the work.

2.8.2 Types

2.8.2.1 Integral water proofer

Admixtures used as integral water proofer shall be free of chlorides and sulphates and shall conform to IS: 2645-1975. The application and doses shall be as per manufacturer's specification.

2.9 Interval of Routine Test



2.9.1 The routine tests of materials, delivered at site, shall be at the following intervals :

Aggregates - Fortnightly or for every 200 m³ for each aggregate whichever is earlier and in other respects generally as per IS : 2386 (Part 1 to 8)-1963.

Cement - Fortnightly or for each consignment, within 4 days of delivery and in other respects generally as per IS : 4031-1988.

Water - Once in two months for each source of supply and in other respects generally as per IS : 456-1978.

Reinforcement - For each consignment within 4 days of delivery in accordance with I.S. 1786-1985, I.S. 1599-1985 and I.S. 1608-1972.

	LAYING, INSTALLATION, TESTING AND COMMISSIONING OF 8" DIA. STEEL GAS PIPELINE CONNECTIVITY IN PATAN GA	
TENDER DOCUMENT NO REPL/SGL/STPL/009/22		Date: -28/11/2022

3.0 STEEL



3.1 For Reinforcement

Reinforcing bars for concrete shall be round steel bars of the following types as may be shown on the drawing :

- i) Plain mild steel bars conforming to Grade-I of IS : 432-1982 "Mild Steel & Medium Tensile Steel for Concrete Reinforcement".
- ii) "High strength deformed steel bars conforming to IS : 1786-1985 for Concrete Reinforcement".
- iii) Reinforcement fabrics conforming to IS:1566-1982 "Hard Drawn Steel Wire Fabric for Concrete Reinforcement"

All reinforcement bars shall be of uniform cross sectional area and be free from loose mill scales, dust, loose rust, coats of paint, oil or other coatings which may destroy or reduce bond. Unit weight of reinforcement bars conforming to I.S. 1786-1985 is as given below.

Nominal Size (Dia) (mm)	Mass Per Metre Run (Kg)
6	0.222
8	0.395
10	0.617
12	0.888
16	1.580
18	2.000
20	2.470
22	2.980
25	3.850

	LAYING, INSTALLATION, TESTING AND COMMISSIONING OF 8” DIA. STEEL GAS PIPELINE CONNECTIVITY IN PATAN GA	
TENDER DOCUMENT NO REPL/SGL/STPL/009/22		Date: -28/11/2022

28

4.830

32

6.310

3.2 Binding wire

Binding wire for reinforcement shall be annealed steel wire 20 BWG conforming to IS : 280 -1978 "Specification for Mild Steel Wire".

3.3 Light structural work and inserts

Steel for light structural work and for preparation of inserts and embedments shall conform to IS: 2062-1992 "Steel for general structural purposes - Specification."

3.4 Steel Tubes

Steel tubes for use in light structural work and inserts shall be of light or medium class (as may be specified in drawings or the schedule of items) and of grade YST 25 conforming to IS : 1161 - 1979 "Specification for Steel Tubes for Structural Purposes".

3.5 Foundation Bolts



3.5.1 Bolts to be embedded in concrete shall, unless otherwise detailed in drawings, conform to IS : 5624-1970 "Specification for Foundation Bolts". Material for bolts, shall, unless otherwise mentioned in drawings or the schedule of items, be of steel conforming to IS : 2062-1992.

3.5.2 Nuts and locknuts shall conform to IS : 1363 (Part 1 to 3) -1992 "Specification for Black Hexagon Bolts, Nuts and Lock Nuts (Diameter 6-39 mm) and Black Hexagon Screws "Specification for Hexagon Bolts and Nuts (M-42 to M-150)".

3.5.3 Plain washers shall conform to IS : 2016 -1967 "Specification for Plain Washers and spring washers shall conform to IS : 3063 -1972 "Spring Washers for Bolts, Nuts & Screws".

3.6 Steel Tubes for Non-structural use

3.6.1 Steel tubes for non-structural use shall conform to IS : 1239 (Part-I) - 1990 "Specification for Mild Steel Tubes, Tubular and Other Wrought

	LAYING, INSTALLATION, TESTING AND COMMISSIONING OF 8” DIA. STEEL GAS PIPELINE CONNECTIVITY IN PATAN GA	
TENDER DOCUMENT NO REPL/SGL/STPL/009/22		Date: -28/11/2022

Steel fittings, Part-I : Mild Steel Tubes".

3.6.2 Fittings for steel tubes used for non-structural purposes shall conform to IS : 1239 (Part-II) -1992 "Specification for Mild Steel Tubular and Other Wrought Steel Pipe Fittings".

3.7 Threaded Fasteners

Bolts and nuts for fastening shall conform to IS:1367 (Part 1)-1980 "Technical Supply Conditions for Threaded Fasteners".

3.8 Testing

Test certificates from manufacturer shall be submitted for each consignment. Any additional test which the Engineer may require shall be done according to IS : 1786-1985, 1566-1982, 280-1978, 2062-1992, 1161-1979, 2614-1969, 3063-1972, 1239 (Part 1 and 2)-1990 and 1992 and 1367-1980.

3.9 Cast Steel

3.9.1 Quality

Cast steel shall conform to IS : 1030-1989 "Carbon Steel Casting for General Engineering Purpose". Unless otherwise specified, it shall conform to Grade2.



3.10 Conduits

3.10.1 Steel for electrical wiring

Rigid steel conduits for electrical use shall conform to IS : 9537 (Part 2) - 1981 for rigid pipes and to IS : 3480-1966 for flexible conduits. Fittings for conduits shall conform to IS : 2667-1988.

All conduit pipes shall be finished with galvanised or stove-enamelled surface. All accessories shall be of threaded type and pipes shall be jointed by means of screwed couplers only. Bend in conduits shall be made to the dimension shown in drawing, but a minimum of 12 times the diameter. Where shown in drawing they shall be treated with anticorrosive preservative as specified.

3.10.2 Non-metallic conduit for electrical wiring

	LAYING, INSTALLATION, TESTING AND COMMISSIONING OF 8" DIA. STEEL GAS PIPELINE CONNECTIVITY IN PATAN GA	
TENDER DOCUMENT NO REPL/SGL/STPL/009/22		Date: -28/11/2022

Non-metallic conduits for electrical use shall conform to IS : 9537 (Part 3) -1983 for rigid pipes and to IS : 6946 -1973 for flexible pipes. Fittings shall conform to IS : 3419-1989.

Bends shall be achieved by bending the pipes by inserting suitable solid or inspection type normal bends, elbows or similar fittings.

4.0 ASBESTOS CEMENT PRODUCTS

4.1 General

Asbestos cement products shall be free from visible defects, uniform in colour, of required density, length, thickness and diameter within the allowable tolerance. They shall be obtained from an approved source of manufacture and stored safely. Methods of test shall be according to IS:5913-1989 "Method of Test for Asbestos Cement Products."

4.2 Building Boards



These shall be of Class A, B and C with board thickness being 6.5mm , 5mm and 4mm respectively. The length shall be 2400, 1800 and 1200mm and width in all cases 1200 mm. Building boards shall conform to IS : 2098 - 1964 "Asbestos Cement Building Boards". They shall, when tested in two perpendicular directions, take a load of not less than 15 kgf for Class-A and 10 Kgf for Class-B and Class-C boards. The boards shall show water absorption of not more than 40% of their dry weight.

4.3 Flat Sheets

Flat sheets shall conform to IS : 2096-1992 "Asbestos Cement Flat Sheets". They shall have a bending stress of not less than 225 kgf/cm² & a density of 1.6 kg/dm³ for compressed sheets & a bending stress of not less than 160 kgf/cm² and a density of 1.2 Kg/ dm³ for uncompressed sheets. Nominal thickness shall be 5,6,8,10 and 15 mm , length 2400, 1800 and 1200mm and width 1200mm. Water absorption shall not exceed 28% of dry wt.

4.4 Pipes and fittings

Pressure pipes shall conform to IS : 1592-1989 "Asbestos Cement Pressure Pipes" and to IS : 9627 -1980 "Asbestos Cement Pressure

	LAYING, INSTALLATION, TESTING AND COMMISSIONING OF 8” DIA. STEEL GAS PIPELINE CONNECTIVITY IN PATAN GA	
TENDER DOCUMENT NO REPL/SGL/STPL/009/22		Date: -28/11/2022

Pipes (Light Duty)". Pipes for sewerage and drainage shall conform to IS : 6908 -1991 "Asbestos Cement Pipes and Fittings for Sewerage and Drainage ". Building pipes gutters and fittings shall conform to IS : 1626 - (Part 1 to 3)-1980 to 1991 "Asbestos Cement Building pipes and pipe fittings".

Pressure pipes shall satisfy Hydraulic test and transverse crushing test as per IS : 5913-1989.

4.5 Corrugated and Semi-Corrugated Sheets

These shall conform to IS : 459 -1992 "Unreinforced Corrugated and Semi-Corrugated Asbestos Cement Sheets". Unless otherwise stated the sheets shall be corrugated and not less than 6mm thick. The sheets shall have a load bearing capacity of not less than 5 N/mm width of specimen and shall not absorb more water than 28% of its dry weight. Overall width of corrugated sheets is 1050mm and of semi-corrugated sheet is 1100mm.



4.6 Asbestos Cement Roof fittings

These shall conform to IS : 1626 (Part 3)-1981. Shapes and dimensions shall be as given in the above mentioned code. All finished products shall be free from visual defects that impair appearance or serviceability. Surface of fittings shall be of uniform texture and shall have neatly trimmed edges. Mean water absorption shall not be more than 28% of dry mass of the material.

5.0 BRICK AND STONES

5.1 Bricks

Bricks for masonry in foundations, walls and other locations shall be common burnt clay building bricks having minimum crushing strength of 5 N/sq.mm., or such other strength as may be described in the Schedule of Items, when tested in accordance with IS : 1077-1992 "Common Burnt Clay Building Bricks". They shall be sound, hard and thoroughly well burnt, with uniform size having rectangular faces with parallel sides and sharp straight right angled edges and be of uniform colour with fine compact uniform texture. Bricks shall be of uniform deep red cherry or copper colour. They shall be free from flaws, cracks and nodules of free lime. Water absorption after 24 hours immersion in cold water shall be

	LAYING, INSTALLATION, TESTING AND COMMISSIONING OF 8" DIA. STEEL GAS PIPELINE CONNECTIVITY IN PATAN GA	
TENDER DOCUMENT NO REPL/SGL/STPL/009/22		Date: -28/11/2022

not more than 20% by weight. They shall not absorb more than 10% by weight of water after immersion for six hours. They shall emit a clear metallic ringing sound when struck by a mallet and shall not break when dropped on their face, from a height of 60 cm. Fractured surface shall show homogeneous, fine grained uniform texture, free from cracks, air holes, laminations, grits, lumps of lime, efflorescence or any other defect which may impair their strength, durability, appearance and usefulness for the purpose intended. Underburnt or vitrified bricks shall not be used. Samples of bricks brought to the site shall be tested periodically for compression and other tests according to IS : 3495 (Parts-1 to 4) -1992 "Method of Test for Burnt Clay Building Bricks". Where the size of bricks is not specifically mentioned, it shall be taken to mean conventional sizes as is commonly available in the area. In case modular bricks are to be used, it shall be accordingly specified in Schedule of Items. The bricks shall be classified on the basis of average compressive strength as given in table 1 of IS : 1077-1992.

5.2 Handling

Bricks shall be unloaded by hand and carefully stacked and all broken bricks shall be removed from the site.

5.3 Samples and Inspection



Representative samples shall be submitted by the contractor and approved samples retained by the Engineer for comparison and future reference. Bricks shall be obtained from approved manufacturer. All bricks shall be subject to inspection on the site and shall be to the approval of the Engineer who may reject such consignment as are considered by him to be inferior to the quality specified. The Contractor shall provide all labour and plant required for the inspection and conduct such test as shall be required by the Engineer without additional charges.

5.4 Brick Bats

Brick bats shall be obtained from well burnt bricks of approved quality.

5.5 Laterite Stone Blocks

These shall conform to IS : 3620 -1979 "Laterite Stone Blocks for Masonry". The laterite stone blocks shall have a minimum compressive strength of 30 kg/cm² and to be tested as per IS : 1121-1974. The

	LAYING, INSTALLATION, TESTING AND COMMISSIONING OF 8" DIA. STEEL GAS PIPELINE CONNECTIVITY IN PATAN GA	
TENDER DOCUMENT NO REPL/SGL/STPL/009/22		Date: -28/11/2022

blocks shall be minimum 15 cm thick but not exceeding 30 cm. They shall be dressed to the desired sizes and shapes with an axe. Laterite stones shall be well seasoned by exposure to air before dressing and using on work.

5.6 Stone (granite, trap, sandstone, quartzite etc.)

5.6.1 Stone used shall be strong, durable, dense, compact, close grained, homogeneous, fire resistant and shall be obtained from sources approved by Engineer. Stones shall additionally be hard, sound, free from cracks, decay and other flaws or weathering and shall be easily workable. Stones with round surfaces shall not be made use of.

5.6.2 Stones shall have a crushing strength of not less than 200 kg/cm². Stones with lesser crushing strength may be used in works with prior approval of the Engineer. Stones shall be non-porous and when tested in accordance with IS : 1124 -1974 "Method of Test for Determination of Water Absorption Etc.," shall show water absorption of less than 5% of its dry weight when soaked in water for 24 hours. Tests for durability and weathering shall be done in accordance with IS : 1126-1974 and IS : 1125-1974 respectively. The working of stones to required sizes and their dressing shall be as per IS : 1127-1970 "Recommendations for dimensions and workmanship of natural building stones for masonry work" and IS : 1129 -1972 "Dressing of Natural Building Stones". Stones especially limestone and sand stones shall be well seasoned by exposure to air before use in construction works.



5.6.3 Size

Normally stones shall be of size that could be lifted and placed by hand, between 20 to 30 kg per piece. The length of stones shall not exceed 3 times the height and the breadth on base shall not be greater than 3/4 of the thickness of wall or less than 15cm. The height of stone may be upto 30cm.

5.6.4 Dressing

5.6.4.1 Random rubble

Stones shall be hammer dressed on the face, the sides, and the beds to enable it to come into close proximity with the neighbouring stone. The bushings in the face shall not project more than 4cm on all exposed faces and 2cm on a face to be plastered, nor shall it have depressions

	LAYING, INSTALLATION, TESTING AND COMMISSIONING OF 8” DIA. STEEL GAS PIPELINE CONNECTIVITY IN PATAN GA	
TENDER DOCUMENT NO REPL/SGL/STPL/009/22		Date: -28/11/2022

more than 1cm from the average wall surface.

5.6.4.2 Coursed rubble - First sort

Face stones shall be hammer dressed on all beds, and joints, so as to give them approximately rectangular block shape. These shall be squared on all joints and beds. The bed joint shall be rough chisel dressed for atleast 5cm back from the face, and side joints for atleast 4cm such that no portion of the dressed surface is more than 6mm from a straight edge placed on it. The bushing on the face shall not project more than 4cm as an exposed face and one cm on a face to be plastered. The hammer dressed stone shall also have a rough tooling for a minimum width of 2.5cm along the four edges of the face of the stone, when stone work is exposed.

5.6.4.3 Coursed rubble - Second sort



Dressing shall be as specified in 5.6.4.2 except that no portion of dressed surface shall exceed 10mm from a straight edge placed on it as against 6mm for first sort.

5.6.4.4 Stone for veneering

Stone lining upto 8cm shall be treated as veneering work. The stone shall be cut into slabs or required thickness along the planes parallel to the natural bed. Every stone shall be cut to the required size and shape so as to be free from any waviness and to give truly vertical and horizontal joints. Adjoining faces shall be fine chisel dressed to a depth of a 6mm, so that when checked with a 60cm straight edge, no point varies from it by more than 1mm. All edges shall be chisel dressed to be true, square and free from chippings. Top and bottom faces shall be dressed to within 3mm tolerance and vertical faces to within 6mm tolerance, when checked with a 60mm straight edge. Dressing at the back shall not be done.

5.7 Hollow and Solid Concrete Blocks

5.7.1 Cement concrete blocks used in the construction of concrete masonry load bearing as well as non-load bearing walls shall conform to the requirements of IS : 2185 (Part 1)-1979. Physical properties such as density, compressive strength, water absorption etc., shall be determined in accordance with the procedure laid down in IS : 2185 (Part 1) - 1979 and shall conform to the requirement laid therein. When inspected

	LAYING, INSTALLATION, TESTING AND COMMISSIONING OF 8" DIA. STEEL GAS PIPELINE CONNECTIVITY IN PATAN GA	
TENDER DOCUMENT NO REPL/SGL/STPL/009/22		Date: -28/11/2022

visually all blocks shall be sound, free from cracks, broken edges, honeycombing and other defects which would interfere with the proper placing of blocks or impair strength or permanence of construction.

5.7.2 Dimensions and tolerance

The blocks shall be made in sizes and shapes to suit the particular job and shall include stretcher, corner, double corner or pier, jamb, header, bullnose and floor units.

5.7.2.1 The nominal dimensions of concrete block shall be as follows :

- Length : 400, 500 or 600mm
- Height : 200 or 100mm
- Width : 50, 75, 100, 150, 200, 250 or 300mm

In addition, blocks shall be manufactured in half and other suitable lengths and shapes to suit Architectural requirements.

5.7.2.2 The maximum dimensional tolerances shall be plus or minus 5mm in length and plus or minus 3mm in height and width.

5.7.3 Hollow blocks (open and closed cavity)



5.7.3.1 The blocks having solid material about 50% to 75% of total volume of the block calculated from the overall dimensions shall be termed as hollow blocks. Grade-A blocks used as load bearing units shall have a minimum block density of 1500 kg/m³ and shall have minimum average compressive strength of 3.5, 4.5, 5.5 or 7.0 N/mm² at 28 days as specified.

5.7.3.2 Grade-B Blocks used as load bearing units shall have block density less than 1500 kg/m³, but not less than 1000 kg/m³ and shall have compressive strength of 2.0, 3.0, or 5.0 N/mm² or as specified.

5.7.3.3 Grade-C blocks used as non load bearing units shall have block density less than 1500 kg/m³, but not less than 1000 kg/m³ and compressive strength of 1.5 N/mm² at 28 days.

5.7.4 Solid blocks

The blocks having solid material more than 75% of the total volume of the block shall be termed as solid block. Solid blocks (Grade-D) used

	LAYING, INSTALLATION, TESTING AND COMMISSIONING OF 8" DIA. STEEL GAS PIPELINE CONNECTIVITY IN PATAN GA	
TENDER DOCUMENT NO REPL/SGL/STPL/009/22		Date: -28/11/2022

as load bearing units shall have a block density of not less than 1800 kg/m³ and compressive strength of 4.0 or 5.0 N/mm² as specified.

5.7.5 Mix proportion

The concrete mix used for blocks shall not be richer than one part by volume of cement to six parts by volume of combined aggregates before mixing.

5.7.6 Surface texture and finish

Surface texture, that is, very fine closed texture or coarse open texture and finish, whether coloured or not shall be according to the drawing, description in the Schedule of Items or instructions of the Engineer.

5.7.7 Marking and certificate

The blocks shall be marked permanently indicating the Grade of the unit, identification of the manufacturer and the year of manufacture. Manufacturers test certificate shall be supplied with the delivery of each lot.



5.8 Cement, Lime and Water

Cement, lime and water shall conform to the specification under the Section Concrete of this part.

5.9 Sand for Masonry Mortar

Sand for masonry mortars shall be natural sand, crushed stone sand or crushed gravel and shall comply with IS : 2116 - 1980 "Sand for Masonry Mortars". The sand shall be hard, durable, clean and free from adherent coatings and shall not contain amount of clay, silt and fine dust more than 5% by wt. Sand shall not contain any harmful impurities such as iron pyrites, alkalies, salts, coal, mica and organic matters. The particle size grading of sand for use in mortars shall be within the limits as specified in Table I of above code.

6.0 SAND FOR PLASTERING

	LAYING, INSTALLATION, TESTING AND COMMISSIONING OF 8” DIA. STEEL GAS PIPELINE CONNECTIVITY IN PATAN GA	
TENDER DOCUMENT NO REPL/SGL/STPL/009/22		Date: -28/11/2022

Sand for use in mortars for internal wall, ceiling and external plastering and rendering shall conform to IS:1542 -1992. It shall not contain any harmful impurities such as iron pyrites, alkalis, salts, coal, mica and organic matters. Percentage of salt and dust shall not be more than 5% by weight. Grading of sand shall be within the limits specified in clause no. 5.1 of above code. Fineness modulus of naturally occurring sand shall not be less than 1.5.

7.0 MATERIALS FOR FLOORING & PAVING

7.1 Cement and Binders

7.1.1 Cement

Cement, fine aggregates, reinforcement and water used shall comply with the requirements of concrete as per clauses 2.1, 2.3, 2.6 and 2.7 of this part.

7.1.2 Water

Water for construction shall be clean, soft, free from loam, salt and organic materials. Hard water shall not be used.

7.2 Aggregates



7.2.1 Coarse Aggregate

7.2.1.1 Coarse aggregate shall conform to the requirement as per clauses 2.1 and 2.2 of this part.

7.2.1.2 For granolithic floor the screeded bed shall comprise of aggregates size 15mm and down graded and topping shall comprise of clean fine stone chippings, size 4mm and down. For concrete floor with hardener treatment the topping shall comprise of stone chippings, size 6mm and down and for in-situ terrazzo flooring, chippings shall be within sizes 12mm to 6mm graded. The marble chips for topping of terrazzo floor shall be of 3-6mm size and shall conform to Grade-I of IS : 2114-1984 "CP for laying in-situ terrazzo floor finish".

7.2.2 Common burnt clay bricks

Common burnt clay bricks shall conform to IS : 1077-1992 and comply with requirements under the section "Brick and Stones" of this part.

	LAYING, INSTALLATION, TESTING AND COMMISSIONING OF 8" DIA. STEEL GAS PIPELINE CONNECTIVITY IN PATAN GA	
TENDER DOCUMENT NO REPL/SGL/STPL/009/22		Date: -28/11/2022

7.2.3 Rubble

Rubble of approved quality shall be used and shall be clean and free from dirt. The loose and weathered sections shall be removed before use. Rubble used as hard core shall have a least lateral dimension (thickness) between 100mm and 225mm, depending on the thickness of hardcore.

7.3 Tiles

7.3.1 Terrazzo Tiles

Terrazzo tiles shall be machine made under a minimum pressure of 140 kg/cm². It shall have a minimum total thickness of 20mm including a minimum of 6mm thick topping. It shall be of size, texture, colour, shade and pattern as specified in schedule of item and as approved by the Engineer.

7.3.2 White Glazed Tile



White glazed tiles shall be of approved manufacture and quality and shall conform to IS:777 - 1988 "Glazed Earthenware Tiles. They shall be true in shape, free from hair cracks, crazing spot, chipped edges and corners and surface shall be perfectly flat without warps and of uniform colour. The top surface shall be glazed either gloss or matt as specified. The tiles, normally shall be 149mm x 149mm or 99mm x 99mm size and shall not be less than 5mm thick or as specified. The tolerance on average facial dimension value shall be plus or minus 0.8 and on thickness plus or minus 0.5mm. The specials such as coves, internal and external angles, beads, cornices and their corner pieces shall be of specified sizes and of thickness not less than the thickness of tiles.

7.3.3 Coloured tiles

Only glaze shall be coloured as specified. The size and specification of tiles shall be same as for the white glazed tiles.

7.3.4 Marble tiles

It shall conform to IS : 1130 -1960 "Marble (Blocks, Slabs and Tiles)".

	LAYING, INSTALLATION, TESTING AND COMMISSIONING OF 8” DIA. STEEL GAS PIPELINE CONNECTIVITY IN PATAN GA	
TENDER DOCUMENT NO REPL/SGL/STPL/009/22		Date: -28/11/2022

Marble for paving and facing work shall be of selected quality, hard, sound, dense and homogeneous in texture (with crystalline texture) and free from cracks, decay, weathering and flaws and shall be of kind and quality, size and thickness as specified in schedule of items. The samples of tiles shall be got approved by the Engineer before use. The tiles shall be cut to the requisite dimensions.

7.4 Pigments

Pigments incorporated in mortar or used for grouting shall be subject to approval of Engineer and as per table I of IS : 2114-1984.

7.5 Red Oxide of Iron

Red oxide of iron where used for "Red Artificial Stone Flooring" shall be of quality approved by the Engineer, and shall be of uniform tint.

7.6 Hardening Agents

Hardening agents such as ironite used for "Cement Concrete Flooring with Hardener Treatment", shall be of quality approved by the Engineer for every work.

7.7 Dividing Strips



Dividing strips shall be of aluminium, glass, brass, copper, plastic or similar materials as specified in the schedule of item and of quality approved by the Engineer. Strips shall be 1.5 mm thick unless otherwise specified penetrating to the full depth of the flooring. Aluminium strips when used shall have a protective coating of bitumen.

7.8 Marble Chips

It shall be in sizes varying from 1mm to 25mm and in different colours as per requirement. Marble chips shall be hard, sound, dense and homogeneous in texture with crystalline and coarse grains. It shall be uniform in colour and free from cracks, stains, decay and weathering and shall be obtained from approved source.

7.9 Marble Powder

It shall be clean, free from dust and other foreign materials and of approved quality, obtained from approved source. It shall pass through sieve 300 conforming to IS: 460- (Part-1)-1985.

	LAYING, INSTALLATION, TESTING AND COMMISSIONING OF 8” DIA. STEEL GAS PIPELINE CONNECTIVITY IN PATAN GA	
TENDER DOCUMENT NO REPL/SGL/STPL/009/22		Date: -28/11/2022

8.0 TIMBER

8.1 General

All timber used for carpentry and joinery works shall be new. It shall be well seasoned by a suitable process conforming to IS : 1141-1973 before being planed to the required sizes. It shall be sound, straight, free from sap, radial cracks, decay, fungal growth, boxed heart, pitch pockets, borer holes, splits, loose knots, flaws or any other defects and shall show a clean surface when cut. Timber shall conform to the requirements of IS : 1003 (Part 1&2)-1983 to 1991. The finished components shall be given suitable preservative treatment wherever necessary.

8.2 Teak wood/Sal / Bija Sal / Deodar / Kail and other varieties of timber

8.2.1 Teak wood



The timber shall be of good quality and well seasoned. It shall be of fairly uniform colour and shall be free from defects such as cracks, dead knots, shakes etc. No individual hard and sound knot shall be more than 15 sq. cm. in size and aggregate area of all such knots shall not exceed 2 % of the area of the piece. Wood shall be generally free from sap wood but traces of the same shall be allowed. The timber shall be fairly grained having not less than 2 growth per cm width in cross section.

8.2.2 Sal / Bija Sal wood

Timber shall be of good quality and well seasoned. It shall have fairly uniform colour, reasonable straight grains and shall be free from all defects as mentioned in previous clauses. No individual hard and sound knot shall be more than 6 sq. cm. in size and aggregate area of all such knots shall not exceed 2 % of the area of the piece. There shall not be less than 5 growth rings per 2 cm of the width.

8.2.3 Deodar wood

The timber shall be of good quality and well seasoned. It shall have fairly uniform colour, reasonable straight grains and shall be free from all defects as mentioned in previous clauses. No individual hard and

	LAYING, INSTALLATION, TESTING AND COMMISSIONING OF 8” DIA. STEEL GAS PIPELINE CONNECTIVITY IN PATAN GA	
TENDER DOCUMENT NO REPL/SGL/STPL/009/22		Date: -28/11/2022

sound knot shall be more than 15 sq.cm. in size and aggregate area of all such knots shall not exceed 2 % of the area of the piece. There shall be at least 3 growth rings per cm width in cross section.

8.2.4 Kail wood

The timber shall be generally as specified in clause 8.2.3 for Deodar wood. However, there shall not be less than 2 growth rings per cm width in cross section.

8.2.5 Other varieties of timber

The timber as named in the item of work shall be used. It shall be well seasoned and generally free from defects such as dead knots, cracks, shakes, sap wood etc. However, traces of sap wood shall be allowed and sound and hard knots up to 2 % of the area of the piece shall be allowed.

8.3 Storage and Inspection

Timber shall be carefully stored and subject to inspection on site, piece by piece. The Engineer may reject such pieces as are considered by him not of the quality or meeting the requirements specified herein.

8.4 Moisture Content



Timber shall be accepted as well seasoned if its moisture content does not exceed the permissible limit as per IS : 287-1973.

8.5 Tolerances for Timber

For timber allowance as specified in the IS : 1003 (Part 1&2) 1983 to 1991 shall be applicable.

8.6 Flush Door Shutters, Shelves

Flush door shutters, shall be wooden, solid core or cellular and hollow core type, as may be shown in drawing or described in the Schedule of Items or directed by Engineer. They shall be obtained from an approved source of manufacture, covered on face with commercial ply, wood veneer or other finish as may be necessary. Solid core shutters

	LAYING, INSTALLATION, TESTING AND COMMISSIONING OF 8” DIA. STEEL GAS PIPELINE CONNECTIVITY IN PATAN GA	
TENDER DOCUMENT NO REPL/SGL/STPL/009/22		Date: -28/11/2022

shall conform to IS : 2202 (Part 1&2)-1983 to 1991 and cellular or hollow core shutters to IS : 2191 (Part 1&2)-1983. The resin used shall be phenol formaldehyde. A full size sample door shall be offered for inspection and approval.

8.7 Wood Particles Boards

Particle boards for general purposes shall be of medium density conforming to IS:3087-1985. These are of four types, Flat pressed single layer board (FPSI), Flat pressed three layer board (FPTH), Extrusion pressed solid board (XPSO) and Extrusion pressed tubular core (XPTU). Adhesive shall be BWR, WWR or un-extended CWR type. High density wood particle board shall conform to IS:3478-1966 and are in flat sheets or moulded forms. These shall be of type 1 (BWR type of resin) or Type 2 (WWR or CWR type of resin). Both types of boards shall be of Grade A (resin content 20 to 50 percent) and Grade : (resin content 8-12 percent).



8.8 Veneered Particle Board

These shall conform to IS : 3097-1980 and shall be of two grades. Exterior (grade-I with BWP or BWR type adhesive) & interior (grade-II with WWR or CWR type adhesive). Each grade of boards shall be of 4 types, solid core general purpose, solid core decorative, Tubular core general purpose and Tubular core decorative and accordingly designated.

8.9 Plywood for General Purpose

Plywood for general purpose shall conform to IS:303-1989. Depending on type of adhesive used for bonding veneers, it is of 4 grades, BWP (boiling water proof), B.W.R (boiling water resistant), WWR (warm water resistant) and CWR (Cold Water resistant). Any species of timber may be used for plywood manufacture. However list of species, for the manufacture of plywood is given in Annexure 'B' of the IS : 303-1989 for guidance.

Plywood is classified in 10 different types as per appearance of the surface. These are type AA,AB,AC,AD,BB, BC,BD,CC,CD and DD as detailed in IS : 303-1984. It is available from 3 ply to 11 ply with thickness from 3mm to 25mm.

	LAYING, INSTALLATION, TESTING AND COMMISSIONING OF 8” DIA. STEEL GAS PIPELINE CONNECTIVITY IN PATAN GA	
TENDER DOCUMENT NO REPL/SGL/STPL/009/22		Date: -28/11/2022

8.10 Veneered Decorative Plywood

This quality of plywood shall conform to IS : 1328-1982. These plywood shall be of two types Type 1 and Type 2 as per details given in IS : 1328-1982. Species of timber for decorative face commonly used are given in Table 1 of IS : 1328-1982 but the purchaser shall specify the particular veneer to be used. Timber for cores and backs shall be either class I or II as specified in IS : 303-1989. Adhesive used shall be BWR or WWR synthetic resin.

9.0 FITTINGS FOR DOORS, WINDOWS, ETC.

9.1 General

Fittings shall be of iron, brass, aluminium or as specified. These shall be well made, reasonably smooth and free from sharp edges, corners, flaws and other defects. Screw holes shall be countersunk to suit the head of specified wood screws. All hinge pins shall be of steel and their riveted heads shall be well formed.



Iron fittings shall be finished bright or black enameled or copper oxidised or painted as specified. Brass fittings shall be finished bright, oxidised or chromium plated and aluminium fittings shall be finished bright or anodised as specified. Fittings shall be got approved by the Engineer before fixing. Screws used for fittings shall be of the same metal and finish as the fittings. However, anodised cadmium/chromium plated M.S. screws of approved quality shall be used for fixing aluminium fittings.

9.2 Hinges

9.2.1 Butt hinges

These shall be mild steel butt hinge (medium), brass butt hinges, extruded aluminium alloy butt hinges or as specified. Type (light/medium/heavy weight) and size shall be as specified in the drawing or schedule of items. Brass / Aluminium and M.S butt hinges shall conform to Indian Standard Specification for butt hinges IS : 205-1992 and IS : 1341-1992 respectively. Hinges shall be finished bright or satin polished or anodised.

9.3 Sliding Door Bolts

	LAYING, INSTALLATION, TESTING AND COMMISSIONING OF 8” DIA. STEEL GAS PIPELINE CONNECTIVITY IN PATAN GA	
TENDER DOCUMENT NO REPL/SGL/STPL/009/22		Date: -28/11/2022

Mild steel sliding door bolts shall conform to IS : 281-1991 and are of 2 types, plate type and clip or bolt type. Plate type bolts shall have plates and straps stove enameled black with hasp and bolt finished bright or copper oxidized or nickel / chromium plated. Clip or bolt type are copper oxidized or plated. All screw holes in the M.S bolts shall be countersunk. Diameter of bolt for plate type is 12mm and for clip type is 16mm.

Non ferrous metal sliding doors are of brass or aluminium alloy and shall conform to IS:2681-1979. Brass sliding bolts are of 150 to 450mm size with bolt dia being 16mm for 150 to 300mm and 18mm for 375 and 450 size. Aluminium alloy sliding bolts are of size 200 to 450mm with 16mm bolt dia. Brass quality is finished satin, polished or plated and aluminium alloy bolts are anodised.

For both ferrous and non-ferrous metal bolts the size of the sliding bolt is determined by the length of the bolt.

9.4 Door Rim Latch



This shall be of mild steel, brass, aluminium alloy or as specified and of sizes 75, 100, 125 and 150mm denoted by overall length of the body measured from outside face of the fore end to the rear end. These are of type 1 and type 2 and shall conform to IS : 1019-1974.

9.5 Tower Bolts

Tower bolts may be of one of the following types and shall conform to IS : 204 (Part 1 and 2)-1991 and 1992.

i) Barrel tower bolts

These shall be of bright finished/stove enamelled/ black painted mild steel tower bolts, brass barrel tower bolts with cast brass barrel and rolled or drawn brass bolt/brass barrel tower bolts with barrel of extruded sections of brass and rolled or drawn brass bolt/brass barrel tower bolts with brass sheet barrel and rolled or drawn brass bolt. Aluminium barrel tower bolts with barrel and bolt of extruded section of aluminium alloy-bolts and barrel anodised.

	LAYING, INSTALLATION, TESTING AND COMMISSIONING OF 8” DIA. STEEL GAS PIPELINE CONNECTIVITY IN PATAN GA	
TENDER DOCUMENT NO REPL/SGL/STPL/009/22		Date: -28/11/2022

ii) Semi-barrel tower bolts

These shall be mild steel semi barrel tower bolts full cover/open type with mild steel sheet pressed barrel and cast iron/mild steel bolt. Bolt bright finished other parts stove enameled black.

iii) Rivetted or spot welded tower bolts

These shall be mild steel tower bolts rivetted type with black flat and mild steel/cast iron bolt and open staple.

iv) Skeleton tower bolts

These shall be of bright finished / stove enameled / black painted mild steel or brass bright finished skeleton tower bolts with cast brass/extruded sections plate and staples and rolled or drawn brass bolt or Aluminium skeleton tower bolts with plates staples and bolt or extruded sections of Aluminium alloy plate and staple anodised.



9.6 Door Handles

Door handles shall conform to IS : 208-1987 and shall be of 4 types. Type 1 is cast Iron / Brass / Aluminium or zinc alloy die casting and available in 75,100,125 150mm sizes. Type 2 is mild steel pressed oval in 75, 100,115 and 135mm sizes. Type 3 is mild steel present half oval in 75,90 and 100mm sizes. Type 4 is fabricated (brass / aluminium alloy) in 75,100 and 125mm sizes. The size of the handle shall be determined by inside (grip) size overall size and internal depth of the handles shall be as detailed in IS : 208-1987.

Finish for type 1 shall be satin/nickel plating, copper oxidising and bronze finish for cast-brass and zinc die cast handles and stove enamelled black or copper oxidized for cast iron handles. Aluminium handles shall be anodized. Type 2 and 3 handles shall be stove enamelled black. For type 4 it shall be satin finish, nickel plating, copper oxidized and bronze finish for brass handles and anodizing for aluminium handles.

9.7 Mortice Lock and Rebated Mortice lock

Mortice lock with latch and pair of lever handles shall have body of

	LAYING, INSTALLATION, TESTING AND COMMISSIONING OF 8” DIA. STEEL GAS PIPELINE CONNECTIVITY IN PATAN GA	
TENDER DOCUMENT NO REPL/SGL/STPL/009/22		Date: -28/11/2022

steel, Aluminium alloy or brass and shall be right or left handed as shown in the drawing or as directed by the Engineer. It shall be of the best Indian make of approved quality and shall conform to IS: 2209 / 6607-1976/1972. The shape and pattern shall be approved by the Engineer. The size of the lock shall be determined by its length. The lock for single leaf door shall have plain face and that for double leaf door a rebated face. Lever handles with springs shall be mounted on plates and shall weigh not less than 0.5 kg per pair. These shall be of brass, finished, bright chromium plated or oxidised. The locks shall be of 65, 75 and 100 mm sizes.

9.8 Floor Door Stopper

These are for the use of the door shutters of 30, 35,40 & 45mm thickness. It is made of aluminium alloy/ brass with springs of phosphor bronze or hard drawn steel wire and tongue of aluminium/brass/nylon/ plastic. The floor door stoppers shall conform to IS : 1823-1980 and shall be best Indian make of approved quality. Width of cover plate is 40mm but its overall length is 140mm for 30 and 35mm thick shutters & 150mm for 40 and 45mm shutters. The body shall be cast in one piece and fixed to cover plate by brass or M.S screws. On the extreme end there shall be rubber cushion to absorb shocks. The extension of the door stopper shall be in flush with floor and be finished bright/satin/chromium plated or anodised.

9.9 Hooks and Eyes



These shall be of mild steel or hard drawn brass and shall generally conform to IS : 207-1964.

9.10 Casement Window Handles

These shall be made of cast brass, steel protected against rusting, aluminium, pressed brass or as specified. Casement handles for single leaf window shutter shall be left or right handed and shall weigh as specified.

9.11 Casement Peg Stays

These shall be made of cast brass, steel protected against rusting, aluminium, cast alloy or as specified. The stay shall be made from a channel section and shall be 300mm long with steel peg and locking bracket. The peg stay shall have three holes to open the window in

	LAYING, INSTALLATION, TESTING AND COMMISSIONING OF 8” DIA. STEEL GAS PIPELINE CONNECTIVITY IN PATAN GA	
TENDER DOCUMENT NO REPL/SGL/STPL/009/22		Date: -28/11/2022

three different angles. The shape and pattern of stays shall be approved by the Engineer. The peg stay shall be minimum 2mm thickness in case of brass and aluminium and 1.25 mm in case of steel.

9.12 Quadrant Stays

These shall be made of cast brass, aluminium alloy, CP iron or as specified. The shape and pattern shall be approved by the Engineer. It shall weigh as specified.

9.13 Fan Light Pivots

These shall be made of mild steel, cast brass or aluminium alloy or as specified and shall generally conform to IS : 1837-1966.

The pattern and the shape of the catch shall be as approved by the Engineer and size and finish shall be as specified.

9.14 Fan light catch

These shall be made of mild steel, cast brass, aluminium alloy or as specified and shall generally conform to IS : 364-1993. Steel springs of the catch shall be 0.90 mm dia, 6 coils, 12 mm internal diameter and 20 mm long. The pattern and the shape of the catch shall be as approved by the Engineer.

9.15 Steel Frames

These shall conform to IS:4351-1976. The frames shall be manufactured from commercial mild steel sheets of 1.25mm thickness and are suitable for door shutters 30 to 40mm thick. The door frames are designated as per profile A, B and C.

Profile A Size 105x60mm : rebated for one set of shutters



Profile B Size 125x60mm : rebated for one set of shutters

Profile C Size 165x60mm : rebated for two sets of shutters.

Miscellaneous Items :

9.16 Putty

The material shall be homogeneous paste and shall be free from dust

	LAYING, INSTALLATION, TESTING AND COMMISSIONING OF 8” DIA. STEEL GAS PIPELINE CONNECTIVITY IN PATAN GA	
TENDER DOCUMENT NO REPL/SGL/STPL/009/22		Date: -28/11/2022

and other visible impurities. Putty shall conform to IS : 419-1967 for wood work.

10.0 METAL DOORS, WINDOWS, VENTILATORS AND ROLLING SHUTTERS

10.1 General

Materials used in the fabrication of doors, windows, and ventilators shall be the best procurable and conforming to relevant Indian Standards.

10.2 Steel Doors, Windows and Ventilators

Steel sections used for fabrication of doors, windows and ventilators shall be standard rolled steel sections specified in IS : 1038, IS : 1977, IS : 1361 or IS : 7452 year 1983, 1975, 1978 and 1990 respectively as appropriate or as specified in drawing and Schedule of Items. Rivets shall conform to IS : 1148-1982.

10.3 Aluminium Door, Windows and Ventilators



Aluminium sections for fabricating doors, windows, ventilators, partitions etc., shall be extruded sections conforming to IS : 1948-1961 & IS : 1949-1961 or as manufactured by Indian Aluminium Company Limited or approved equivalent The alloy used shall conform to Designation HE 9 - WP of IS : 733-1983.

10.4 Steel Rolling Shutters, Rolling Grills

These shall conform to IS : 6248-1979.

10.5 M.S. Bolts etc.

M.S. bolts, nuts, screws, washers, peg stays and other mild steel fittings shall be treated for corrosion. Putty for glazing shall conform to IS : 419-1967. Glass panes and glazing shall conform to the specification detailed under this series.

	LAYING, INSTALLATION, TESTING AND COMMISSIONING OF 8" DIA. STEEL GAS PIPELINE CONNECTIVITY IN PATAN GA	
TENDER DOCUMENT NO REPL/SGL/STPL/009/22		Date: -28/11/2022

10.6 Hardware and fixtures shall be as specified in the drawings or Schedule of Items. All hardware and fixtures shall be able to withstand repeated use. Door closers shall be suitable for doors weighing 61 80 kg, unless otherwise stated. Each closer shall be guaranteed against manufacturing defect for one year and any defect found within this period shall be rectified or the closer replaced free of charge. Concealed door closers shall be either floor mounted or transom mounted, suitable for installation with metal doors. It shall conform to the performance requirements and endurance test stated in IS : 3564 1986 Appendix-A.

10.7 The mastic for caulking shall be of best quality from a manufacturer approved by the Engineer. In general, the mastic for fixing of metal frames shall conform to IS : 1081-1960 and/or as approved by the Engineer.

11.0 GLASS

11.1 General

Plain, ground, frosted or rough cast wired glass shall be used as shown on the drawing or as specified in the Schedule of Items. It shall be procured from a reputed source of manufacture and be of the best quality. All glass panes shall be free from flaws, specks, bubbles etc. Glass panes shall be of thickness 3mm or more as required. Weight of 3mm thick glass pane shall not be less than 7.5 Kg//sqm. The tolerance of glass panes, except wired glasses, in length and width shall be plus or minus 2 mm for 3 to 6.3 mm glass sheets. Tolerance in thickness of glass sheets shall be +/- 0.2mm for 3mm and 4mm thick glasses and +/- 0.3mm for 4.8, 5.5 and 6.3mm thick glasses.

11.2 Plain Transparent Glass

Plain transparent glass for glazing and framing shall conform to IS: 2835-1987. It shall be free from flaws, specks, bubbles or distortions.

11.3 Ground and Frosted Glass

Glare reducing or heat absorbing glass shall be "Calorex" or approved equivalent and special care shall be taken to grind smooth and round off the edges before fixing.



**LAYING, INSTALLATION,
TESTING AND COMMISSIONING
OF 8” DIA. STEEL GAS PIPELINE
CONNECTIVITY IN PATAN GA**



TENDER DOCUMENT NO
REPL/SGL/STPL/009/22

Date: -28/11/2022

11.4 Thickness

Glass shall have the following thickness, unless otherwise stated in the Schedule of Items or drawings

- Upto 60 cms x 60 cms ... 3 mm
- do- of larger size ... 4 mm and 4.8mm
- Sheet glass for doors..... 5.5 mm
- Rough cast wired 6.4 +/- 0.4 mm

11.5 Inspection

All glasses shall be subject to inspection on the site. Glass found to suffer from defects shall be rejected. Samples submitted for inspection shall be selected so as to be representative of the consignment.

12.0 PAINTS

12.1 General



All paints, varnishes, distemper or other surface coating materials shall be of approved quality conforming to the appropriate Indian Standard, wherever such standard is available, and be obtained from a manufacturer of repute. If there is more than one quality for one particular product, only first quality shall be used unless otherwise stated in the Schedule of Items.

12.2 Sampling and Testing

The Engineer may, at his discretion, require samples of paint to be tested. In such cases testing will be according to IS : 101 (Part 1 to 8) - 1964 to 1993.

12.3 Storage

Paints, primers, distempers and varnishes shall be delivered in sealed containers. They shall be stored in cool dry condition to the satisfaction of the Engineer.

	LAYING, INSTALLATION, TESTING AND COMMISSIONING OF 8" DIA. STEEL GAS PIPELINE CONNECTIVITY IN PATAN GA	
TENDER DOCUMENT NO REPL/SGL/STPL/009/22		Date: -28/11/2022

12.4 Paints for Priming

Ready mixed paints for priming coats of steel and iron work shall either comply with IS : 2074-1992 "Ready Mixed Paint", "Red Oxide Zinc Chrome Priming" or Red Oxide metal primer as specified. For wood work it shall be pink/white wood primer as specified by the manufacturer of the synthetic enamel paints, conforming to IS : 3536-1966.

12.5 Paints for finishing

Ready mixed oil synthetic enamel paint of approved manufacturers like Berger, Jenson & Nicholson, Shalimar, I.C.I., Asian, Garware and Goodlass Nerolac paints only shall be used unless otherwise specified. Paint shall be of first grade quality of the above manufacturers ie., Luxol Brolac, Superlac, Dulox gloss, Apocolite, Garcoat and Nerolac respectively.

If for any other reason, thinning is necessary, the brand of the thinner recommended by the manufacturer, shall only be used with the specific permission of the Engineer.

Aluminium paint for general purpose shall be in Dual Containers. It shall be of manufacturers as for synthetic enamel paints above.

12.6 White wash



White was shall be prepared from freshly burnt fat, white in colour lime slaked on spot, conforming to IS : 712-1984 mixed and stirred with sufficient water to make a thin cream. Best and approved quality gum and ultra marine blue only shall be used in lime wash.

12.7 Colour wash

Colour wash shall be prepared by adding mineral colours, not affected by lime, to white wash.

12.8 Water proofing Cement Paint

Cement paints shall comply with IS: 5410-1992 and shall be of approved brand and manufacture like Snowcem India Ltd., Berger, Jenson & Nicholson & Shalimar paints. The shade shall be approved

	LAYING, INSTALLATION, TESTING AND COMMISSIONING OF 8" DIA. STEEL GAS PIPELINE CONNECTIVITY IN PATAN GA	
TENDER DOCUMENT NO REPL/SGL/STPL/009/22		Date: -28/11/2022

by the Engineer before its application.

12.9 Distemper

Dry/synthetic washable distemper of approved brand and manufacture like Berger, Jenson & Nicholson, Asian, Shalimar, Garware & Goodlass Nerolac shall be used. The shade shall be approved by the Engineer before application of the distemper. and shall comply with IS : 427-1965 and IS : 428-1969.

12.10 Varnish

Varnish for the finishing coat shall be copal finish or synthetic class varnish of approved brand. Varnish for the under coat shall be flattening varnish of the same make as the top coats and shall be to the satisfaction of the Engineer.

12.11 Polish

French spirit polish shall be of an approved make conforming to IS: 348-1968. In case it is to be prepared on site, the polish shall be made by dissolving 0.7 kg of best, shellac in 4.5 litres of methylated spirit without heating. To obtain required shade pigment may be added and mixed. Shellac shall conform to IS : 5467-1986.



12.11.1 Wax polish for Wood work

The polish shall consist mainly of waxes and Organic solvents with or without water and shall be of smooth consistency, homogeneous, Semi-Solid mass and free from gritty materials. It shall not flow at ordinary temperature. It may be tinted with an oil soluble colour. The polish shall not crumble or dry too rapidly and shall produce non-tacky polished surface. The polish shall be amenable to smooth spreading on the furniture surface and the gloss shall appear on gentle rubbing with a soft polishing cloth.

The wax polish shall conform to IS : 8542-1977.

12.11.2

Where wax polishing is to be prepared at site, it shall be prepared by heating two parts of "Bee Wax" two parts of boiled linseed oil over a slow fire. When dissolved but still warm, one part of turpentine is to be added. The boiled linseed oil, bees wax and turpentine used shall be of approved quality and complying with IS : 77-1976, IS : 1504-1974 and

	LAYING, INSTALLATION, TESTING AND COMMISSIONING OF 8” DIA. STEEL GAS PIPELINE CONNECTIVITY IN PATAN GA	
TENDER DOCUMENT NO REPL/SGL/STPL/009/22		Date: -28/11/2022

IS : 533-1973 respectively.

12.12 Plastic (Acrylic) emulsion paint

Plastic emulsion paint of approved manufacturers like Jenson & Nicholson, Goodlass Nerolac, Shalimar, Berger, Asian and Garware paints only shall be used unless otherwise specified and shall comply with IS : 5411 (Part 1)-1974 & (Part 2)-1972 as applicable. Cement primer used for priming work both for oil bound distemper and plastic emulsion paint shall be of the same manufacture as that of distemper or plastic emulsion paint used. For dry distemper priming, whitening of approved quality shall be used.

12.13 Creosote oil or Coaltar Creosote



It is primarily used for preservation of wood. It shall be a homogeneous liquid and shall liquify completely on being warmed to 38 degree C with stirring and shall remain liquid on cooling down to 32 degree C and on standing at that temperature for 2 hours.

The material shall conform to IS : 218-1983. All persons handling the creosote oil should be fully aware of the hazards involved in handling . Skin should be protected from coming in direct contact and eyes should be protected by using safety goggles while handling the material.

12.14 Coaltar Black Paint

Coaltar paint film protects surfaces by serving as a barrier against the action of moisture and other corrosive agents. Coaltar black paint is generally used as a protective and anti corrosive paint of iron and steel as well as protection of other building surfaces. For this it has to be applied under proper condition and on suitably prepared surface. Coaltar should be applied by brush only and is not recommended for locations which are not likely to be well ventilated. Coaltar paint shall conform to IS : 290 1961.

The material is of two types : Type A Quickly drying and Type B Slow drying. It shall be a homogenous black solution type paint consisting of a base prepared by blending suitable grades of Coaltar pitch, washed free from ammoniacal liquor, tar acid bases etc. Consistency, permeability, thickness and surface preparation etc. shall be as per

	LAYING, INSTALLATION, TESTING AND COMMISSIONING OF 8" DIA. STEEL GAS PIPELINE CONNECTIVITY IN PATAN GA	
TENDER DOCUMENT NO REPL/SGL/STPL/009/22		Date: -28/11/2022

para 5 and A-2 of the above code.

12.15 Floor Polish - Paste

The polish shall consist mainly of waxes and organic solvents with or without water.

The paste floor polish shall be of smooth consistency, homogenous, semi-solid-mass and free from gritty material. It shall not flow at ordinary temperature. It shall be so constituted and prepared that on application by means of a clean cloth, it shall spread easily and evenly and shall give with minimum buffing a firm and glossy surface free from greasiness or tackiness. The polish film after spreading with a cloth shall not take more than 10 minutes to dry. The polished floor shall neither be slippery nor show any resistance to easy walking.

Floor polish paste shall conform to IS : 8591-1977.

13.0 WATER PROOFING MATERIALS

13.1 Integral Cement Waterproofing Compounds



Integral cement waterproofing compounds, i.e. admixture for waterproofing purposes shall fully comply with the requirements of IS : 2645-1975. Properties like permeability, setting time, compressive strength shall be in accordance with the requirements of this code when tested as per procedure laid therein. Calcium chloride content of the product used shall be made known to Engineer before use.

13.2 Bitumen

The bitumen bonding material for waterproofing shall conform to the requirements laid down in IS : 702-1988 or IS : 93-1992 or IS : 217-1988 or IS : 454-1961 depending upon whether industrial bitumen, paving bitumen or cutback bitumen is used. For selecting the particular type and grade of bitumen to be used the relevant item in Schedule of Items shall be referred to.

13.3 Bitumen Primer

Bitumen primer used for application to concrete and masonry surfaces and bitumen for the purpose of waterproofing shall conform to requirements given in IS : 3384-1986 and pass tests in accordance

	LAYING, INSTALLATION, TESTING AND COMMISSIONING OF 8" DIA. STEEL GAS PIPELINE CONNECTIVITY IN PATAN GA	
TENDER DOCUMENT NO REPL/SGL/STPL/009/22		Date: -28/11/2022

with the procedure laid down in appropriate IS mentioned in Table-I of IS : 3384-1986. Bitumen primer should be free from water and shall preferably ;be made from the same grade of bitumen as used in bonding.

13.4 Bitumen Felt

Bitumen felts used for water proofing purposes shall be as specified in IS: 1322-1982. Physical properties shall conform to the requirements and tests shall be carried out as per procedure laid down in IS :1322-1982. Base, (whether fibre or Hessian), type and grade of felt shall be as mentioned in the relevant items under Schedule of Items. Unless otherwise stated, hessian base felt Type-3, Grade-2 shall be used.

13.5 Bitumen Mastic

Bitumen mastic used for water proofing of roofs shall have the physical properties as mentioned in IS : 3037-1986 when tested with the procedure laid down in appropriate IS mentioned in IS : 3037-1986.

13.6 Bituminous Compounds



Bituminous compounds when used for waterproofing of porous masonry, concrete floors, walls and roofs shall conform to the requirements of IS : 1580-1991. Physical properties shall be governed by the requirements of this code when tested in accordance with the procedure laid therein.

13.7 Surface Application Materials

Waterproofing material for application on mortar or concrete surface shall conform to IS: 9862 1981. The primer shall be suitable for spray or brush application. It shall have properties enabling it to penetrate through pores or cracks and fill them up, making the surface impervious.

13.8 Polymer based paints

The materials used shall be high polymer based chloride and sulphide free cement and waterproofing additions and epoxy based waterproofing paints as per manufacturer's specification and approved by Engineer.



	LAYING, INSTALLATION, TESTING AND COMMISSIONING OF 8" DIA. STEEL GAS PIPELINE CONNECTIVITY IN PATAN GA	
TENDER DOCUMENT NO REPL/SGL/STPL/009/22		Date: -28/11/2022

13.9 Fibre glass R. P. Tissue

The fibre glass R.P. tissue is a thin flexible uniform mat, composed of glass fibre in an open porous structure bonded with a suitable inert material compatible with coal tar, asphaltic enamel and oil plastic based wall paint. The fibrous glass mat is reinforced with continuous filament glass yard at 3/8" (10mm) pitch in the longitudinal direction.

PHYSICAL PROPERTIES

- | | | |
|------|-------------------|--|
| i) | Weight | The average weight of fibre glass R.P. tissue shall not be less than 50 gms/sq.sm. |
| ii) | Thickness | The fibre glass R.P. tissue shall have a thickness not less than 0.4mm. |
| iii) | Tear Strength | The tear strength shall be not less than 900 grams in the transverse direction. |
| iv) | Breaking Strength | This shall have a minimum breaking strength of 13 lb/in (2.32kg/cm) in the longitudinal direction. |
| v) | Porosity | This shall have a porosity when related to pressure difference across the sample of not less than 0.022" (0.56mm) and not more than 0.76" (1.92mm) of water guage at an air velocity of 200fpm.(100cm/sec.). |
| vi) | Pliability | There shall be no cracking of the tissue mat when bent over a 1/8" (3.2mm) radius after immersing for 10-15min. through a 90 degree arc. |
| vii) | Temperature | The fibre glass tissue shall be Resistance under a load of hot bitumen at 530 degree F (276 degree C) for one minute. |

	LAYING, INSTALLATION, TESTING AND COMMISSIONING OF 8” DIA. STEEL GAS PIPELINE CONNECTIVITY IN PATAN GA	
TENDER DOCUMENT NO REPL/SGL/STPL/009/22		Date: -28/11/2022

13.9.1

Primer

Primer shall conform to requirements laid down in IS : 3384-1986. It is to be prepared by blending turpentine and blown grade bitumen in the ratio of 60:40 by weight.

13.9.2

Blown Materials

Blown grade bitumen shall be conforming to IS : 702-1988 and residual grade bitumen conforming to IS:73 respectively. This shall be prepared by heating to correct working temperature.

13.9.3

Surface finish

Pea sized gravel/grit 6mm and down.

13.10

P.V.C. Membrane/Sheets

Polyvinyl chloride sheets for the purpose of water proofing and other underground use are specially developed sheets made from the compounded resin of grade MP/DP/CR-02 and shall be resistant to the passage of gross water and water vapour. It shall be corrosion resistant and resistant to a wide range of acidic and alkali reagents, saltpetre action, salt water and ultra violet rays etc. PVC sheets manufactured by approved and reputed firms like Maxlok Polymer Ltd. shall only be used

The sheets shall consist of Knobs or Lugs jutting out of the sheets in a grid fashion so as to provide a perfect grip in the mortar and concrete. Sheet thickness, spacing of the knobs and their projection from the sheet shall be as specified in the item. The sheets shall be of maximum practicable length and width unless otherwise specified.



The adhesive used for jointing shall be of approved quality and of grade C-02.

The sample of the material shall be got approved before use.

13.10.1

Properties

- i) Chemical Composition : Resin Plasticiser Inhibitor
Stabiliser UV Barrier.
- ii) Thickness : Not less than 0.25 mm

	LAYING, INSTALLATION, TESTING AND COMMISSIONING OF 8" DIA. STEEL GAS PIPELINE CONNECTIVITY IN PATAN GA	
TENDER DOCUMENT NO REPL/SGL/STPL/009/22		Date: -28/11/2022

- iii) Rupture/Tensile Strength : Not less than 225Kg/cm²
- iv) Adhesive bond Strength : : Not less than 7.1 Kg/cm [width]
- v) Elongation at Break : 130%

14.0 WATER BAR

14.1 General

Water bar for use in construction/expansion joints in concrete and reinforced concrete structures shall be of copper sheet, galvanised steel sheet, rubber or PVC as shown in drawing or described in the Schedule of Items. It shall be subject to approval of Engineer.

14.2 Jointing

The water bar shall have dimensions as shown in drawing. Where water bars are required to be lengthened or otherwise jointed the joining shall be done in such a way as to achieve a perfectly watertight joint.

15.0 LEAD



15.1 General

Lead for joints in cast iron spigot and socket pipes shall be melted from pure soft pig lead conforming to Type-I of IS : 782-1978. "Caulking Lead". Where lead wool is allowed for caulking, it shall be equal to or better than Type-II of IS : 782-1978. Lead flashing shall conform to IS : 405 Part I&II-1992.

16.0 BUILDING PAPER

16.1 Building paper shall be bitumen impregnated paper conforming to IS: 5134 1977, or such other as may be approved by the Engineer.

17.0 FILLING MATERIAL

	LAYING, INSTALLATION, TESTING AND COMMISSIONING OF 8” DIA. STEEL GAS PIPELINE CONNECTIVITY IN PATAN GA	
TENDER DOCUMENT NO REPL/SGL/STPL/009/22		Date: -28/11/2022

17.1 General

Filling material shall conform to what is shown in drawing, described in the Schedule of Items or otherwise directed by the Engineer. Earth or sand for filling under floors shall correspond to those described elsewhere in these specifications.

17.2 Mastic Bitumen

Mastic Bitumen shall conform to IS : 3037-1986 or IS : 5871-1987 as appropriate.

17.3 Flexible Boards



Flexible boards for use in expansion joints shall correspond to the description given in drawing or the Schedule of Items or the instruction of Engineer.

18.0 DRAINAGE & SANITATION (INTERNAL)

18.1 General

All materials, pipes, specials, fittings, fixtures etc., to be used in the works shall be of best quality and class specified in relevant IS Code. Where specified these shall be of specific manufacture and quality and shall be procured from manufacturer or their accredited stockists and be marked with manufacturers' names and trade mark. Contractor shall submit to the Engineer samples of all materials, pipes, specials, fittings fixtures for approval before use in the works. Such approved samples shall be retained by the Engineer till completion of works. Pipes and Specials may be any or combination of followingtypes:-

- i) PVC Pipes
- ii) Stone Ware Pipes
- iii) Sand Cast Iron Pipes for soil waste & Ventilation
- iv) CI Pipes for rain water
- v) AC Pipes for rain water
- vi) R.C.C Pipes

	LAYING, INSTALLATION, TESTING AND COMMISSIONING OF 8" DIA. STEEL GAS PIPELINE CONNECTIVITY IN PATAN GA	
TENDER DOCUMENT NO REPL/SGL/STPL/009/22		Date: -28/11/2022

18.1.1 High density PVC pipes and fittings

This shall conform to IS : 4984-1987 and IS : 8008 (Part 1 to 7)-1976 unless otherwise specified.

18.2 PVC Waste Pipe

This shall conform to IS : 4985-1988 unless otherwise specified.

18.3 Stoneware Pipes & Fittings



All stoneware pipes, bends, gully traps and sewer traps shall be of the best salt glazed variety inside and outside, hard burnt dark grey colour, perfectly sound, free from fire cracks and imperfection of glaze, truly circular in cross section, perfectly straight, of standard nominal length and depth of socket and barrel. These shall be of approved manufacture and shall comply with the requirement of IS: 651-1992. These pipes shall be of grade AA unless otherwise specified.

18.4 Sand Cast Iron Pipes & Fittings conforming to IS : 1729-1979

All soil waste and vent pipes and fittings used in the work shall be cast iron and shall conform to IS: 1729-1979. The pipes shall have spigot and socket ends, with bead on spigot end and shall be with or without ears. The pipes shall be free from cracks and other flaws. The interior of the pipe and fittings shall be clean, smooth painted inside and outside with DR Angas smiths solution or other approved anti-corrosive paint.

The standard weights and thickness of pipe shall comply with the requirements of IS: 1729-1979. The tolerance on wall thickness and weight shall be minus 15 percent and minus 10 percent respectively. Pipes weighing more than the nominal weight given below may be accepted provided they comply in every other respect.

Nominal size	Weight per piece in Kg. excluding ears		
	Overall length		
	1500 mm	1800 mm	2000 mm
50	9.56	11.41	12.65
75	13.83	16.52	18.37
100	18.14	21.67	24.15
150	26.70	31.92	35.66

	LAYING, INSTALLATION, TESTING AND COMMISSIONING OF 8” DIA. STEEL GAS PIPELINE CONNECTIVITY IN PATAN GA	
TENDER DOCUMENT NO REPL/SGL/STPL/009/22		Date: -28/11/2022

Specials and Fittings shall include bends, offsets, branches of various types, junctions etc., as required for the work which shall be provided according to drawings and directions of the Engineer. B.M. trap shall have water seal as per I.S. provisions.

The specials and fittings shall be provided with access doors where so specified or directed by the Engineer. The access door fittings shall be of proper design so as not to form cavities in which the filth may accumulate. Doors shall be provided with 3 mm thick rubber insertion packing, and when closed and bolted they shall be water tight. The access doors shall have MS studs and bolts or screws or bolts and nuts.

18.5 Cast Iron Pipes & A.C. pipes : Rainwater pipe

18.5.1 Pipes shall be of approved manufacture, true, smooth and cylindrical, their inner and outer surfaces being as nearly as practicable concentric and shall conform to IS : 1230-1979. These shall be sound and uniform casting, free from laps, pin holes or other imperfections and shall be neatly finished inside and outside. The ends of pipes shall be reasonably square to their axis.



18.5.2 Dimensions

CI rain water pipes shall be of the dia specified in the description of the item and shall be in full lengths of 1.8 metres including socket ends of the pipes, unless shorter lengths are required at junctions with fittings. The pipe lengths shall in each case be with sockets. The pipes shall be supplied without ears unless otherwise specifically mentioned.

The pipes supplied shall be factory painted with a tar based composition both inside and outside which shall be smooth and tenacious unless specified otherwise.

Every pipe shall ring clearly when struck all over with a light hand hammer. When shorter pipes are cut from full lengths they shall be cut with a hacksaw.

Where the pipes are to be embedded in masonry they shall be of Class of pipes as are used for soil and vent pipes. For the weights of different sizes of these pipes, the specifications under SCI and vent pipes may be referred to.

	LAYING, INSTALLATION, TESTING AND COMMISSIONING OF 8" DIA. STEEL GAS PIPELINE CONNECTIVITY IN PATAN GA	
TENDER DOCUMENT NO REPL/SGL/STPL/009/22		Date: -28/11/2022

18.5.3 A.C. pipes and fittings the pipes and fittings shall be of approved manufacture and shall conform to IS:1626. These shall be homogeneous and free from cracks and other defects. The pipes shall be straight, smooth and regular in thickness.

The diameter of the pipe shall be as specified. The fittings like heads, bends of different degrees, offsets of different projections, shoes and junctions shall be of the type, diameter and size as required for the work. The pipes shall be used in full lengths as far as possible.



18.6 Sanitary appliances

Sanitary appliances like I.W.C/E.W.C pans, wash basin, urinals and sinks etc. shall be made of vitreous china or fire clay as specified. These shall be of Hindustan Sanitary ware or Parry ware make unless otherwise specified and to be approved by the Engineer. These shall conform to A class quality of IS : 2566 (Part 1 to 15)-1972 to 1985 and IS : 771 (Part 1 to 15) -1979 & 1985 respectively.

18.6.1 European Pattern W.C.

Unless otherwise specified, these shall comprise of :

- a) White 'glazed earthenware wash down closet set with 'S' or 'P' trap of standard size.
- b) 'Duco' spray painted 12.5 litres mosquito proof low level M.S or C.I flushing cistern with valveless siphon, 15 mm ball cock, C.P. brass unions & couplings for the 32 mm dia flush pipe, 20 mm dia overflow PVC pipe with mosquito proof cover etc.
- c) 'Duco' spray painted 1 1/4" (32 mm) dia G.I. telescopic flush pipe with buffer clamp, holder bat clamp and 38mm dia PVC pipe or 35/40mm O.D. high density polythene flush pipe with buffer clamp, holder bat clamp.
- d) Approved quality solid plastic W.C. seat and cover, bar hinges, screws bolt, rubber buffers conforming to IS : 2548 (Part 1&2)-1983.
- e) 15 mm PVC connection pipe with brass couplings at both ends and 15 mm brass CP cock.

	LAYING, INSTALLATION, TESTING AND COMMISSIONING OF 8" DIA. STEEL GAS PIPELINE CONNECTIVITY IN PATAN GA	
TENDER DOCUMENT NO REPL/SGL/STPL/009/22		Date: -28/11/2022

- f) Hard wood wooden blocks or other suitable fixing arrangement with screws and detofix for fixing WC in floor and putty joint with flush pipe and soil pipe.

18.6.2 Indian Pattern W.C.



Unless otherwise specified these shall comprise of :-

- a) White glazed earthenware WC pan back entry type.
- b) White glazed earthenware 'P' or 'S' trap with or without vent.
- c) 12.5 litres approved make mosquito proof M.S.high level flushing cistern with valveless siphon, 15 mm ball cock, galvanised iron chain handle, cast iron brackets with wall plugs, brass unions and couplings for flush pipe, 20 mm dia overflow PVC pipe with mosquito proof cover etc.,
- d) 32 mm dia GI telescopic or 35/40 mm O.D high density PVC flush pipe with holder bat clamps.
- e) One pair of white glazed earthen ware foot rest set in cement mortar 1:3.
- f) 15 mm PVC connection pipe with brass couplings at both ends and 15 mm brass stop cock.

18.7 Wash Hand basin

Unless otherwise specified these shall comprise of :-

- a) White glazed earthenware basin with 2 nos. Concealed Cast Iron Brackets with wall plugs.
- b) 1 no. 15 mm C.P. brass pillar tap.
- c) 32 mm C.P. brass waste fitting, C.P. brass chain and rubber plug.
- d) 32 mm PVC waste pipe with brass couplings/32 mm C.P. bottle trap.

	LAYING, INSTALLATION, TESTING AND COMMISSIONING OF 8" DIA. STEEL GAS PIPELINE CONNECTIVITY IN PATAN GA	
TENDER DOCUMENT NO REPL/SGL/STPL/009/22		Date: -28/11/2022

- e) 15 mm PVC connection pipe with brass couplings and 15 mm brass stop cock.

18.8 Flat Back Lipped Urinal

Unless otherwise specified these shall comprise of:-

- a) White glazed earthenware urinal basin back type.
- b) CI/M.S mosquito proof high level automatic flushing cistern of capacity as specified in the Schedule of Quantities with all accessories, cast iron brackets with wall plugs, brass unions and coupling for flush pipe, 20 mm dia overflow pipe with mosquito proof cover.
- c) 25 mm dia CP brass flush pipe and spreaders with wall clips and brackets.
- d) 15 mm PVC connection pipe with brass couplings joint at both ends and 15 mm brass stop cock.
- e) 32 mm C.P. brass outlets complete with PVC waste.



18.9 Mirror Frames

Mirror frame where specified shall be of fibre glass of approved shape, size, colour and make.

- 18.9.1 Mirror shall be of superior glass with edges rounded off or leveled as specified. It shall be free from flaws, specks or bubble and its thickness shall not be less than 5.0 mm. The glass for the mirror shall be uniformly silver plated at the back and shall be free from silvering defects. Silvering shall have a protective uniform covering of red lead paint.



18.10 Toilet Shelf

- 18.10.1 Glass shelf unit shall consist of an assembly of glass shelf, anodised aluminium / CP brass guard rail and supporting brackets. The shelf shall be of glass of best quality with edges rounded off and shall be free from flaws, specks, bubbles and of thickness not less than 5.0

	LAYING, INSTALLATION, TESTING AND COMMISSIONING OF 8" DIA. STEEL GAS PIPELINE CONNECTIVITY IN PATAN GA	
TENDER DOCUMENT NO REPL/SGL/STPL/009/22		Date: -28/11/2022

mm. The shelf shall have guard rail, resting on rubber washers on glass plate.

- 18.10.2** Ceramics shelf shall be of shape, size and design as specified in the Schedule of Items.
- 18.11** **Towel Rail**
- Towel rail shall be of CP brass / anodised aluminium with two brackets of same material, diameter and length as specified.
- 18.12** **Soap Container**
- Soap container shall be of C.P brass, PVC with cp brass brackets of approved make and design.
- 18.13** **CP Flush Valves for EWC**
- The CP flush valve for EWC shall be of "Jaquar" brand of Jaquar & Co., 'ACCO' brand of Asia Continental Metallwaren Fabric or equivalent quality.
- 18.14** **CP Flush Valve for Urinals**
- CP flush valve for urinal shall be of "Jaquar" brand of Jaquar & Co., 'ACCO' brand of Asian Continental Metallwaren Fabric or of equivalent quality.
- 18.15** **Gully Trap**
- Each gully trap shall have one C.I. grating 150 mm x 150 mm and one water tight pre-cast R.C. cover 300 x 300 x 40 mm thick with 1:1 1/2:3 mix concrete (one cement: one and half sand : 3 stone chips 20 mm down) including neat cement finish.
- 18.16** **CI Manhole Covers & Frames**
- These shall be of light or medium duty (LD or MD) as specified in Schedule of Items and of cast iron with raised chequered design, lifting key and key hole and shall be coated with black bituminous base material,. Light duty covers and frames shall be of either rectangular type, single seal, pattern 1 and 2 having minimum weight of cover and

	LAYING, INSTALLATION, TESTING AND COMMISSIONING OF 8” DIA. STEEL GAS PIPELINE CONNECTIVITY IN PATAN GA	
TENDER DOCUMENT NO REPL/SGL/STPL/009/22		Date: -28/11/2022

frame 38 Kg and 25 Kg. respectively or with double seal, minimum weight of cover and frame being 52 Kg. These may be of square type also. Single seal with clear openings of 455 and 610 mm with minimum weight of cover and frame being 20 Kg and 38 Kg respectively, double seal of same openings shall have minimum Wt. of cover and frame 30 Kg and 55 Kg respectively. Medium duty covers and frames shall be either of circular type with 500 and 560 mm clear openings and minimum Wt. of cover and frame 116 Kg and 128 Kg respectively or of rectangular type with minimum Wt. of cover and frame 144 Kg.

The C.I. manhole covers and frames shall conform to IS : 1726-1991.

18.17 Flushing Cisterns

Manually operated high level and low level flushing cisterns are of 5 litre and 10 litre capacities, both single flush and dual flush type. The cisterns shall conform to IS : 774-1984 and be made of Cast Iron, Vitreous China or enamelled pressed steel. The cisterns shall be mosquito-proof.



The thickness of the body including cover shall be not less than 5 mm for Cast Iron and 6 mm for Vitreous China Cisterns. Steel and lead flush pipe shall have internal diameter of 32 plus or minus 1 mm for high level cisterns and 38 plus or minus 1mm for low level cisterns. For high density polyethylene and unplasticised PVC pipes the outside diameter of the pipe shall be 40 mm. In case of PVC plumbing pipes the outside diameter of the pipes shall be 40mm for high level and 50mm for low level cisterns. Steel flush pipes shall be hot dip galvanized electroplated or vitreous enameled.

The flush pipe shall be securely connected to the cistern outlet and made airtight by means of a coupling nut. Float valve shall conform to IS : 1703-1977 or IS : 12234-1988. Polyethylene float valve shall conform to IS : 9762-1981.

Cast Iron Cisterns shall be painted and finished in accordance with recommendation made in IS : 1477 (Part 1&2)-1971 or shall have a coating of enamel.

In general, Materials Construction and operational and performance requirements shall be as specified in para 3, 4 and 6 of IS : 774-1984.

18.18 Plastic Seats & Covers for Water Closets

	LAYING, INSTALLATION, TESTING AND COMMISSIONING OF 8” DIA. STEEL GAS PIPELINE CONNECTIVITY IN PATAN GA	
TENDER DOCUMENT NO REPL/SGL/STPL/009/22		Date: -28/11/2022

These shall conform to IS : 2548 (Part 1&2)-1983 and shall be either of thermo-set or of thermo-plastic quality.

Thermo-set Seats and Covers are moulded from phenolic plastics (Type A) or Urea Formaldehyde (Type B). Thermo-plastic Seats and Covers are also of Type A, moulded from Polystyrene or Type B, moulded from Polypropylene.

Underside of the seats may be either flat or recessed and colour shall be as agreed. Table Dimensions of the seats and covers shall be as per Table-I of the Code (both Part 1&2). Hinging device may be either of the following materials :

- i) Bronze or Brass with Nickel Chromium Plating
- ii) Mild Steel with Nickel Chromium Plating
- iii) Aluminium alloy with anodic coating
- iv) Suitable plastic with reinforcement.

19.0 WATER SUPPLY & PLUMBING (INTERNAL)



19.1 General

This section deals with the specification of material for pipes, fittings, fixtures etc., to be used in water supply works.

All materials, pipes, fittings, fixtures to be used in the works shall be of the best quality and of the class specified in various clauses herein under. Where specified these shall be of specific manufacture and quality and shall be procured from the manufacturer or their accredited stockist and be marked with manufacturers name and trade marks. The Contractor shall submit to the Engineer samples of all pipes, fittings, fixtures for approval before being used in the works. Such approved samples shall be retained by the Engineer till completion of works.

Pipes and pipe fittings may be of any or combination of following types:

- i) Wrought iron galvanised pipe
- ii) PVC pipes
- iii) Cast iron pipes

	LAYING, INSTALLATION, TESTING AND COMMISSIONING OF 8" DIA. STEEL GAS PIPELINE CONNECTIVITY IN PATAN GA	
TENDER DOCUMENT NO REPL/SGL/STPL/009/22		Date: -28/11/2022

- iv) Steel pipes coated with bitumen composition inside and galvanised outside.
- v) Reinforced concrete pipes
- vi) Asbestos cement pipes
- vii) Pre-stressed concrete pipes
- viii) Lead pipe (not to be used for potable water)



19.2 Galvanised Iron Pipes and Fittings

Generally pipes for installations in buildings shall be medium quality malleable steel galvanised pipe 'B' class for cold water supply and 'C' class for hot water supply, having threaded ends with socket at one end.

The details of standard medium quality "B" class pipes and sockets regarding nominal bore thickness and weight in kg/m are given below:-

Pipe Dia (Nominal Bore)	Dimension of Pipe		Thick -- ness	Dimension of ordinary socket		Wt. of Pipe plain end Kg/m
	Max. (outside dia)	Min.		Outside dia (approx.)	Min. length	
mm	mm	mm	mm	mm	mm	
15	21.8	21.0	2.65	26.90	34	1.21
20	27.3	26.5	2.65	33.70	36	1.57
25	34.2	33.5	3.25	42.00	43	2.42
32	42.9	42.0	3.25	51.00	48	3.11
40	48.8	47.9	3.25	57.00	48	3.59
50	60.8	59.7	3.65	70.00	56	5.07
65	76.6	75.3	3.65	88.00	65	6.49
80	89.5	88.0	4.05	101.60	71	8.43

Note :- Manufacturing tolerances shall be permitted on tubes and sockets in addition to above as per IS : 1239 (Part 1&2) 1990 to 1992.

	LAYING, INSTALLATION, TESTING AND COMMISSIONING OF 8" DIA. STEEL GAS PIPELINE CONNECTIVITY IN PATAN GA	
TENDER DOCUMENT NO REPL/SGL/STPL/009/22		Date: -28/11/2022

The galvanised iron pipes shall be of approved make and conform to IS:1239 (Part 1&2) 1990 to 1992 and of tested quality. The GI pipes shall be of threaded ends with a socket at one end only. The fittings for GI pipes shall be either galvanised wrought iron or galvanised malleable iron.

19.3 R.C.C, Asbestos, Prestressed Pipes and Fittings

These shall be of approved manufacture and quality and shall conform to IS : 458 1988, IS : 1592 1989, IS : 9627 1988 & IS : 784 1978 respectively.

19.4 Cast Iron Pipes and Fittings

The cast iron pipes shall be of approved manufacture and quality and shall conform to IS: 1536 1989 "Centrifugally Cast (Spun) iron pressure pipe and/or IS : 1537 1976". Vertically Cast Iron pressure pipe for water, gas and sewage. CI fittings shall conform to IS : 1538 (Part 1 to 23) 1976.



19.5 Steel Pipes

This shall conform to IS: 1239 (Part 1&2) 1990 to 1992) and IS : 3589-1991. Steel pipes shall be coated with bituminous composition inside and galvanised outside.

19.6 Bib Tap and Stop Tap

Bib tap and stop tap for water services shall be of brass screw down type and shall conform to IS: 781. Minimum finished weight of bib and stop taps shall be as given below:

No. of size (mm)	Bib taps (kg)	Stop tap (kg)
10	0.30	0.35
15	0.40	0.40
20	0.75	0.75
25	1.25	1.30
32	-	1.80

	LAYING, INSTALLATION, TESTING AND COMMISSIONING OF 8” DIA. STEEL GAS PIPELINE CONNECTIVITY IN PATAN GA	
TENDER DOCUMENT NO REPL/SGL/STPL/009/22		Date: -28/11/2022

40	-	2.25
50	-	3.85

The taps shall be tested under internal hydraulic pressure of at least 20 kgf/cm² and maintained at the pressure for a period of at least two minutes during which period it shall neither leak nor sweat.

19.7

Valves

Unless otherwise mentioned in the Schedule of Quantities these shall be copper alloy gate, globe and check valve of nominal sizes 8 to 100mm and shall conform to IS : 778 1984. Valves shall be of class 1 and class 2, suitable upto a temp. of 45 degree C and can sustain non shock working pressure upto 1.0 and 1.6 MPA respectively. They shall have screwed or flanged ends. All the metal parts shall be of brass/brass alloy except hand wheel of Cast Iron or other approved quality.

19.8

Shower Rose

The shower rose shall be of heavy quality chromium plated brass with flat bottom, of diameter 100 mm or as specified with uniform perforations.

19.9

Storage Tank

Storage tank shall be either pressed steel, Galvanised iron, R.C.C or PVC of specified sizes, capacities, make, manufacture as specified in Schedule of Items. It shall have facilities for connecting inlet, outlet overflow and washout pipes and a top cover. Where tanks are to be fabricated by the Contractor the fabrication/R.C.C detailed drawings shall be got approved by Engineer.

19.10

Miscellaneous items



19.10.1

Half round channel

This shall be made of vitreous china channel with or without outlet/stop end as specified in Schedule of Items and shall be of approved manufacture.

19.10.2

Urinal partition

	LAYING, INSTALLATION, TESTING AND COMMISSIONING OF 8" DIA. STEEL GAS PIPELINE CONNECTIVITY IN PATAN GA	
TENDER DOCUMENT NO REPL/SGL/STPL/009/22		Date: -28/11/2022

This shall be made of vitreous china or R.C.C. with mosaic finish or marble as specified and shall be of approved make and quality.

20.0 EXTERNAL SEWERAGE & DRAINAGE

Unless otherwise specified CI pipe and specials, caulking lead, SW pipe, RCC pipe shall conform to the following.

20.1 C.I. Pipes

- i) C.I. pipe shall conform to IS : 1536 - 1989 or/and IS : 1537 - 1976 of class as specified in Schedule of Items.
- ii) C.I. pipe fittings shall conform to IS : 1538 (Part 1 to 23) -1976 as specified in Schedule of Items.
- iii) Bolts and nuts shall be hexagonal bolts and nuts conforming to IS : 1363 (Part 1 to 3) - 1992.

20.2 Washers

Spring washers conforming to IS : 3063 - 1972 shall be used near the pumps to take care of vibration. In other places plain washers conforming to IS : 2016 - 1967 shall be used.

20.3 Gaskets



Gaskets shall be reinforced rubber sheet or compressed fibre board conforming to IS : 638 - 1979 of thickness between 1.5mm to 3mm or as specified.

20.4 Caulking Lead

Lead for the spigot and socket joints shall conform to IS : 782 - 1978.

20.5 Salt Glazed Stone Ware Pipes

Salt glazed stone-ware pipes used shall conform to IS : 651 - 1992 and

	LAYING, INSTALLATION, TESTING AND COMMISSIONING OF 8” DIA. STEEL GAS PIPELINE CONNECTIVITY IN PATAN GA	
TENDER DOCUMENT NO REPL/SGL/STPL/009/22		Date: -28/11/2022

shall be laid as per IS : 4127 - 1983. The pipes shall be of grade AA unless otherwise specified.

20.6 Steel Pipes

Steel pipes and fittings used for encasing shall conform to IS : 1239 (Part 1&2) - 1990 to 1992 medium Class upto 150 mm dia and as per IS : 3589 - 1991 for pipes of dia 200 mm and above. For pipes of dia 200 mm and above fittings, if required shall be fabricated from pipes itself.

20.7 Cast Iron Manhole Covers & Frames

These shall be of medium or heavy duty (M.D. or H.D.) as specified in Schedule of Item and of Cast Iron with raised chequered design, lifting key and key hole and shall be coated with black bituminous base material. Medium duty covers and frames shall be either of circular type with 500 mm clear opening and minimum weight of cover and frame 116 Kg and 128 Kg respectively or of rectangular type with minimum weight of cover and frame 144 Kg.

Heavy duty covers and frames shall be either of circular type with clear openings of 500 and 560 mm and 170 and 208 Kg weight respectively or of double triangular type with clear openings of 500 and 560 mm and 229 and 255 Kg weight respectively.

The CI manhole cover and frames shall conform to IS : 1726 - 1991.



21.0 ROAD

21.1 General

Roads shall be understood to include road bed, the wearing surface, berms, foot-paths, kerbs, culverts and bridges.

21.2 Soling Stones

Material for soling shall be natural stone boulders or crushed blast furnace slab. Stones for soling shall be of height equal to thickness of the soling with tolerance of plus or minus 25mm and shall not have a base area of less than 250 sq.cm. nor more than 500 sq.cm. and the smallest dimension of any stone shall not be less than half the largest dimension. Stones shall be tough, angular, durable and generally free from flat,

	LAYING, INSTALLATION, TESTING AND COMMISSIONING OF 8” DIA. STEEL GAS PIPELINE CONNECTIVITY IN PATAN GA	
TENDER DOCUMENT NO REPL/SGL/STPL/009/22		Date: -28/11/2022

elongated, soft and disintegrated particles. They shall also be free from dirt or other objectionable matter and be obtained from quarries approved by the Engineer.

Crushed slag obtained from air-cooled blast furnaces slag shall be angular, of reasonably uniform quality and density and generally be free from any thin, elongated, and soft pieces, dirt or other objectionable matter. The density of slag should not be less than 1.12 gm/cc and glassy material shall not exceed 20%. Water absorption when determined in accordance with IS:2386 (Part-III) - 1963. "Methods of Tests for Aggregates for Concrete : Specific Gravity, Density Voids, Absorption and Bulking", shall not exceed 10%.



21.3 Coarse Aggregate for Water Bound Macadam

Coarse aggregate for water bound macadam shall be natural gravel, crushed stone obtained from approved quarries or crushed blast furnace slag. Crushed stone shall be hard, durable, tough and of uniform quality, generally free from flat, elongated, soft and disintegrated particles. It shall have sharp edges and also not have excess of dirt and other objectionable matter. When tested as per IS: 2386 (Part-IV) - 1963 for Los Angeles Abrasion Value or Aggregate Impact Value, the limiting values shall be 50% and 40% respectively for base course and 40% and 30% respectively for surfacing course. The flakiness index shall not exceed 15% when tested in accordance with IS: 2386 (Part-I)-1963 "Methods of Test for Aggregates for Concrete : Particle size and Shape". Crushed slag aggregates shall meet the requirements given for soling stones from blast furnace slag.

Size and grading requirements of coarse aggregates shall be as specified in Table-2 of IRC : 19 - 1981, "Standard Specification and Code of Practice for Water Bound Macadam". The grading number of the table shall correspond to the following layer thicknesses :

Grading Number	Size Range	Layer Thickness
1	90 mm to 40 mm	More than 90 mm
2.	63 mm to 40 mm	90 mm to 75 mm
3.	50 mm to 20 mm	75 mm to 50 mm

21.4 Screenings

	LAYING, INSTALLATION, TESTING AND COMMISSIONING OF 8" DIA. STEEL GAS PIPELINE CONNECTIVITY IN PATAN GA	
TENDER DOCUMENT NO REPL/SGL/STPL/009/22		Date: -28/11/2022

Screenings used for filling voids in coarse aggregates for water bound macadam shall generally be of the same material as the coarse aggregate. Non-plastic materials such as Kankar nodules, moorum or gravel (other than river bore rounded aggregates) may be used, provided that the liquid limit and plasticity index are below 20 and 6 respectively. The fraction passing 75 microns sieve shall not exceed 10%. Size and grading of screenings shall be as specified in Table-3 of IRC-19 - 1981. Type-A screening shall be used for grade number 1 coarse aggregate. Type-B screenings shall be used for grade number 3. Either Type-A or Type-B screenings may be used for grade number 2.

21.5 Stone Chips for Bituminous Surfacing

Coarse aggregate shall consist of crushed stone, crushed slag or crushed gravel (Shingle) retained on 2.36 mm sieve. The aggregates shall be clean, strong, durable and fairly cubical, free from disintegrated pieces, organic and other objectionable matter. The aggregates shall preferably be hydrophobic and of low porosity. The mechanical properties and grading shall be in accordance with IRC-29 - 1988 "Tentative Specifications for 4 cm Asphaltic Concrete Surface Course", having aggregate impact value 30%, Flakiness Index 25% and graded between 20mm and 2.36 mm.

21.6 Sand



Sand for use as fine aggregate in bituminous surfacing shall consist of crushed screenings, natural sand or a mixture of both, passing a 2.36mm sieve and retained on 75 micron sieve. It shall be clean, hard, durable, uncoated and dry, free from injurious, soft or flaky pieces and organic deleterious substances.

21.7 Binder

Binding material for water bound macadam shall consist of fine grained material such as stone dust, kankar modules or moorum. The plasticity index shall be between 4 to 9 when water bound macadam is to be used as surface course and upto 6 when used as sub/base or base course.

21.7.1 Paving Bitumen

It shall conform to IS : 73 - 1992 and shall be of the specified type and grade. The material shall be homogeneous and shall not foam when heated to 175 degree C. Various properties like specific gravity, flash

	LAYING, INSTALLATION, TESTING AND COMMISSIONING OF 8" DIA. STEEL GAS PIPELINE CONNECTIVITY IN PATAN GA	
TENDER DOCUMENT NO REPL/SGL/STPL/009/22		Date: -28/11/2022

point, softening point, penetration etc. shall be as given in the above code.

21.7.2 Bitumen Cut Back

Bitumen cut-back shall conform to specification given in IS : 217 - 1988. It shall be of three types, Rapid Curing (RC), Medium Curing (MC) and Slow Curing (SC). These shall comply with the requirements specified in Table - 1, 2 and 3 respectively of the above code.

The above three types of cutback bitumens shall be classified into different grades on the basis of Kinematic viscosity. Rapid curing type shall be used with aggregates containing practically no fine aggregates passing through 2.36 mm sieve. Medium curing bitumen shall be used with aggregates containing less than 20 per cent of fine aggregates passing through 2.36 mm sieve. Slow curing type shall be used with aggregates containing more than 20 per cent of fine aggregate passing through 2.36 mm sieve.

Medium curing bitumen of 30 grae i.e. MC 30 shall be used as primer. Manufacturer shall indicate source and type of the bitumen.

21.8 Kerbs

Kerbs may be of stone, concrete or brick as may be shown in drawing or otherwise directed by Engineer.

21.8.1 Stone kerbs

Stones shall conform to the dimensions and shapes given in drawing.



Exposed faces shall be dressed to lines.

21.8.2 Concrete kerbs

Shape and dimension shall conform to the drawing. They shall be pre-cast and the road side top corner shall be given a chamfer.

21.9 Galvanized Steel Barbed Wire for Fencing

These shall be of two types A&B. In both types Barbs shall have 4 points formed by twisting two point wires, each two turns. In type A (Iowa type) twisting is done around both line wings and in type B (Glidden type)

	LAYING, INSTALLATION, TESTING AND COMMISSIONING OF 8" DIA. STEEL GAS PIPELINE CONNECTIVITY IN PATAN GA	
TENDER DOCUMENT NO REPL/SGL/STPL/009/22		Date: -28/11/2022

around one line wire, in both cases making altogether four complete turns. It shall conform to IS : 278 - 1978 and shall have the diameter of line and point wire as described in schedule of item. Galvanized mild steel wire shall conform to IS : 280 - 1978.

Line and point wire shall be circular in section, free from scales and shall be uniformly galvanized. Line wire shall be in continuous length and shall not contain any welds other than those in rod before it is drawn.

21.10 Galvanized Steel Chain Link Fabric

It will conform to IS : 2721 - 1979. It shall be of width, mesh and wire dia as per description of Item. For chain link fabric having width upto 2.00 M, of all mesh sizes, two line wires shall be provided. Whereas for width of 2.40 M and mesh size exceeding 50mm three line wires shall be provided. These shall be provided at top and bottom of the fabric, but wherever three line wires have been specified, these shall be provided at top, bottom and middle of fabric.



The mesh wire and line wire of the fabric shall be manufactured from Galvanised steel conforming to IS : 280 - 1978. It will have zinc coating of type medium as given in IS : 4826 - 1979. " Specification for Hot dipped galvanized coatings on round steel wires". Unless otherwise mentioned in the description of item fabric with both ends twisted shall be used.

The galvanised steel pipe posts shall consists of 80 mm and 50 mm nominal diameter. The pipe posts shall conform to IS : 1161 and shall be of medium grade and galvanised.

21.11 Concertina Coil fencing

Angle iron post and strut shall be as specified in Clause 3.3 Part I of specification. Concertina Coil fencing shall be dia 600 mm (having 50 nos. round per 6 metre length), spring core(2.5mm thick) wire of high tensile strength of 165 kg/sq.mm with tape(0.52 mm thick) and weight 43.478 gm/metre.

22.0 LIST OF MATERIALS OF APPROVED BRAND AND/OR

	LAYING, INSTALLATION, TESTING AND COMMISSIONING OF 8" DIA. STEEL GAS PIPELINE CONNECTIVITY IN PATAN GA	
TENDER DOCUMENT NO REPL/SGL/STPL/009/22		Date: -28/11/2022

MANUFACTURE

Unless otherwise specifically mentioned in the Schedule of Items, Contractor has to use materials as listed below, of only these brand names/Company's names, which are mentioned in the approved list for civil, water supply and sanitary items thereon.

SI No	Items/Name of Products	Makes / Brands / Manufacturers
1.	Reinforcement Steel	TATA,SAIL,RINL,IISCO,RATHI
2.	Cement	Ambuja,ACC,JK,Grasim,Ultratech,Birla,L&T,Cement Corporation of India,Maihar
3.	Structural Steel	TATA,SAIL,RINL,IISCO,ESSAR, ISPAT
4.	Pre- engineered building (PEB) firms	Kirby Building system India ltd ,Interach Building Product limited, Tata blue scope steel ,Lloyd Insulation India ltd, Everest Industries. Ltd. Modern Prefab System Pvt Ltd,Aster Building Solution Pvt.Ltd, Octamec Engineering Ltd,Jindal Mectec Pvt Ltd,Fedders Liyod Corporation Ltd.
5.	Structural Steel Tubes ISI Marked	TATA, JINDAL , SURYA , SWASTIK
6.	(a) Zinalume colour coated steel sheet(COIL) (b) Profile of Sheet(as per tender specification)	(a)Tata Blue scope, Dongbu Steel ,Union Steel, JSW STEEL Ltd. Kirby Building system India ltd ,Interach Building Product limited, Tata blue scope steel ,Lloyd Insulation India ltd, Everest Industries. Ltd. Modern Prefab System Pvt Ltd,Aster Building Solution Pvt.Ltd, Octamec Engineering Ltd,Jindal Mectec Pvt Ltd,Fedders Liyod Corporation Ltd
7.	Polycarbonate Sheet	Sabic Innovative Plastic , Everest
8.	Mineral wool for thermal insulation of ceilings (Under deck insulation)	Rock wool (india) Ltd. Minwool Rock Fibres Ltd., Lloyd Insulation,
9.	Rolling shutters(ISI marked)	Swastic, Hercules, Shubdwar, M/s Bharat Rolling Shutters Industries Agra, Bengal Rolling Shutter Rama Rolling Shutter Works, Gandhi Entrance Automations Private Limited



**LAYING, INSTALLATION,
TESTING AND COMMISSIONING
OF 8" DIA. STEEL GAS PIPELINE
CONNECTIVITY IN PATAN GA**



TENDER DOCUMENT NO
REPL/SGL/STPL/009/22

Date: -28/11/2022

10.	Wind driven air Ventilators	Apurva Enterprises (Mumbai), SVS Wind Driven Turbo Ventilator(Ahmadnagar), Real Green Engineers Pvt.Ltd. Bangalore; SunGreen Ventilation system Pvt.Ltd. Mylapore-Chennai, Citadel
		Mumbai, Multi colour, Anchit Ispat Pvt Ltd. (Faridabad),
11.	Synthetic Enamel Paint (1st quality only)	ICI Paint (Dulux), Asian Paint (Apcolite), Berger Paints (Luxol). Goodlass Nerolac Paints (Nerolac), Jenson & Nicholson Paints Ltd (Borolac), Shalimar, Garware & Goodlass
12.	G.I SHEET	ESSAR, JSW, SAIL
13.	Sheeting Screw	Corroshield, Buildex,
14.	Chemical for Antitermite treatment	DE- NOCIL Bombay, Pest Control of India, Trishul
15.	Factory made Panelled Door shutter	M/s Goel Brothers Raipur New Industrial Area Raipur (CG) M/s Hindustan Housing factory Ltd- New Delhi M/s Delhi Construction Eqpt Sadar Bazar Delhi M/s Joinery manufacturing Co Calcutta M/s Goyal Industries Faridabad M/s Surbhi Metal (India) Ltd Jodhpur M/s Jain wood Industries Sonipat/Rohini Delhi (HO) M/s Poineer Timber Products, Chandigarh
16.	Flush doors IS-2191, 2202	M/s Mysore Wood Products M/s Laxmi Doors, Faizabad Road, Chinhat, Lucknow M/s Merino flush doors M/s Poineer Timber Products, Chandigarh, M/S Goyal Industries Faridabad M/s National M/s Century Plyboards (i) Limited.
17.	Fly proof doors (Made out of solid block marine grade)	M/S Laxmi Doors, Faizabad Road, Chinhat, Lucknow, Northern doors Kanpur
18.	Natural Fibre Thermo Composite door/window shutter & frames, roofing sheets etc	Durosam
19.	PVC Panel Door (Solid Core)	Rajshri Plastiwood Limited, Sintex, Hindopan, Marino



**LAYING, INSTALLATION,
TESTING AND COMMISSIONING
OF 8" DIA. STEEL GAS PIPELINE
CONNECTIVITY IN PATAN GA**



TENDER DOCUMENT NO
REPL/SGL/STPL/009/22

Date: -28/11/2022

20.	Pressed steel door frames/ cupboard and window frames (manufacturers)	M/s SAIL, M/s TATA
21.	Pressed steel door frames/ cupboard and window frames (fabricators)	M/s Loyal safe works Mayapuri, N/Delhi M/s Multiwyn Industrial Corpn Calcutta M/s Metal Window Corpn N/Delhi M/s Chhabra Steel Udyog, 260 Sadar Bazar, Meerut Cantt M/s Delite safe works, Rani Jhansi Road, N/Delhi M/s Ishwar Industries, 175/A Bombay Bazar, Meerut Cantt M/s Chandni Industries, J-142, Patel Nagar 1st, Ghaziabad.
22.	Steel Windows, Ventilators(as per IS-1038 of 1983) & frames pressed steel door/window	M/S Multiwyn Industrial Corpn Calcutta M/S Metal Window Corp N/ Delhi Govind Enterprises, Delhi M/S Chhabra Steel Udyog 260, Sadar Bazar, Meerut Cantt, Agent steel MFG Pvt Ltd, Ahmedabad, Godrej, M/S Chandni Industries, J-142, Patel Nagar 1st, Ghaziabad
23.	Al Section for Al Door/ Window/ Partitions	Hindalco, Indal, Ajit India, Jindal
24.	Aluminium Door/ Window/ Glazing Fabricated and Anodized	M/s Ahlcon M/s Alumilite Pvt Ltd, M/s Ajit India Pvt Ltd, M/s Ramniklal S Raste Agra, Argent Industries, M/s Aluminium Tech Industries, I-2249 DSIDC Narela, Delhi, M/s VR Associates, GH-14/242 Paschim Vihar, Delhi
25.	Aluminium door and windows Fittings	M/s Elite Enterprises C/6 Shalimar Hardware 133, Jarg Mahal, Dhobitalao Mumbai 400002. M/s Mohan Metal Industries 178/2-A, Bhole Nath Nagar, Shahadara, Delhi 110032. Mepro, Argent New Delhi, Classic, New Delhi. Jindal, Argent New Delhi, Golden Industries Pvt. Ltd. ECIE
26.	Automatic Glass Door	Ditec (Gandhi)
27.	Aluminium Grill	Alu Grill, Arihant Aluminium Corporation, Decogrille
28.	Door Closer	Everite, Golden, Gandhi
29.	Floor Spring	Prabhat, Everite



**LAYING, INSTALLATION,
TESTING AND COMMISSIONING
OF 8” DIA. STEEL GAS PIPELINE
CONNECTIVITY IN PATAN GA**



TENDER DOCUMENT NO
REPL/SGL/STPL/009/22

Date: -28/11/2022

30.	Builders Hardware	M/s Golden Industries Pvt. Ltd., Everite, Solo, Hardwyn
31.	Plywood for general purpose (IS-303)	National Plywood Inds Pvt Ltd, S Fancy lane, 8th floor Calcutta-700001, Merino Plywood, Archid Ply, Kitply, Swastik, Universal
32.	Prelaminated Particle board	Kitply, Bhutan board, Ecoboard, Novapan, Archid ply, Merinova, Merino
33.	Laminated Sheets	Formica, Merino Lam, Greenlam, National
34.	Modular Partitions	Godrej, Blowplast
35.	False Ceiling (Mineral Fibre Board)	Armstrong, , Daiken, Luxalon, Llyods, Gypboard, Trac, Aerolite
36.	False Ceiling (POP/ Gypsum Board)	Gypboard, Anchor ceiling tiles, LA
37.	Aluminium False Ceiling	Lloyds, Armstrong, Luxlon, Trac
38.	Flooring Tiles (Mosaic / Terrazzo / PCC) (1st quality only)	M/S Mehtab Tiles, NITCO, Royal Tiles, Gem Tiles, Hindustan Tiles, M/S National Tiles & Industries, Ultra Tiles
39.	Glazed Ceramic Tiles, Non-Skid (Floor/Wall), (1st quality only)	Kajaria, Somany, NITCO. Murudeshwar Ceramic Ltd (Navin Diamond tile), Johnson (Marbonite), Marbitto, Somany, Orient, Asian
40.	Vitrified/ Designer Vitrified Tiles (1st quality only)	Asian, Marbonite (Johnson), Kerrogres (Kajaria), NITCO, Orient
41.	PVC Tiles/Flooring (IS 3461) (1st quality only)	Marblex Tiles, Krishna Tiles, Polyfin, Armstrong, Wonder floor.
42.	False Flooring	Godrej or equivalent
43.	Glass Mosaic Tiles (1st quality only)	Paladio, Coral, Accura, Bisazza, Italia, Mridul.
44.	Designer Paver Tiles/ Interlocking tiles ISI marked/ Grass-jointed Tiles (1st quality only)	Pavit, Ultra, Hindustan, Eurocon, Vyara, National Tiles, Gem, Unistone, Konkrete, Unitile
45.	Glass reinforced Paver block	Unistone or equivalent
46.	Wall care Putty for Base preparation (1st quality only)	Birla Wall care putty, Berger, Jenson & Nicholson, JK White
47.	White Cement (1st quality only)	Birla, JK



**LAYING, INSTALLATION,
TESTING AND COMMISSIONING
OF 8” DIA. STEEL GAS PIPELINE
CONNECTIVITY IN PATAN GA**



TENDER DOCUMENT NO
REPL/SGL/STPL/009/22

Date: -28/11/2022

48.	Cement based Paints (1st quality only)	Super Snowcem, Duracem, Super Acrocem.
49.	Dry Distemper / Oil bound Distemper (1st quality only)	Goodlass Nerolac Paint, Shalimar Paint, Jenson & Nicholson, Asian Paint, Berger. ICI Dulux
50.	Acrylic Washable Distemper (1st quality only)	Asian, Berger, ICI Dulux, Jenson & Nicholson, Nerolac, Shalimar, Garware & Goodlass
51.	Plastic Emulsion Paint (1st quality only)	Asian, Berger, ICI, Nerolac, Jenson & Nicholson, Shalimar, Garware & Goodlass
52.	Exterior Acrylic Emulsion (1st quality only)	ICI (Weathercoat), Excel (Nerolac), Apex (Asian), Berger, Jenson & Nicholson, Shalimar, Garware & Goodlass
53.	Polymer based Paint	STP, CICO
54.	Textured Paint / Wall Tile (1st quality only)	Unitile, Heritage, Spectrum, Iokos, Acropaints, Asian
55.	Flexible board for Expansion joint	STP or equivalent
56.	Grout	Shrinkomp, Fosroc, Fairmate
57.	Integral water proofing compound	STP, Pidilite, Fosroc, CICO, Sika.
58.	Concrete Admixture	Pidilite, Fosroc, CICO, Sika.
59.	Water proofing for cementitious surface IS-2645	Acrocrete & Acrocote, CICO, Fosroc, STP
60.	Bituminous Product	M/s Faridabad Spinning & Woolen Mills Pvt Ltd, 837, SP Mukherjee Marg Delhi, M/s STP Ltd (Formerly Shalimar Tar Products) M/s Bitufelt Pvt Ltd 123/377 Fazalm Ganj Kanpur 208012, Texas, Texas India Ltd, Multiplas, IWL Chennai
61.	Hardeners	Ironite, Ferrok, Hardonate
62.	Construction Chemicals	Choksey, CICO, Forsroc, Sika
63.	Non Metallic Surface Hardners	CICO, Fosroc, STP, Sika
64.	Corrugated, Semi Corrugated & AC Sheets (IS-459- 1970, IS-2098)	M/s Everest Bldg Products Ltd Jata Sankar Bosa Marg Mulanand (west) Bombay 400080, M/s Ramco AC Sheets “SWASTIK”, M/s Eternit Everest Ltd, UP Asbestos Ltd



**LAYING, INSTALLATION,
TESTING AND COMMISSIONING
OF 8” DIA. STEEL GAS PIPELINE
CONNECTIVITY IN PATAN GA**



TENDER DOCUMENT NO
REPL/SGL/STPL/009/22

Date: -28/11/2022

65.	GI Sheet ISI Marked	Multicolor, TATA, Bluescope, JSW, Colour Plus, Interarch, Lloyds, Jindal, Everest
66.	Sheet Glass /Structural Glazing	Hindustan Pilkington Glass Works, Saint Gobain, Modi Float, Triveni Float Glass, ASI, Fresca, Emirates.
67.	Multiell / Multiwall Polycarbonate Panel	M/s Coxwell Domes Engineering, Delhi, M/s Lexan, M/s Gallina India Pvt. Ltd. M/s Vijaynath Interiors & exteriors products
68.	Stainless Steel Cladding	Jindal
69.	Punch Tape Concertina Coil	Global Technocrat, S.G.Engineers Delhi
70.	Punch Tape in Plastic Spool	Global Technocrat, S.G.Engineers Delhi
71.	Stainless Steel Railing	Jindal
72.	FRP/ HDPE Garbage Bins	Sintex, Swift, Nutech, Sheetal
73.	Thermoplastic Road Marking Paint	Shalimark (STP)
74.	Bollard	STP
75.	Cateye	TATA, STP
76.	Readymade Speed Breaker	STP
77.	Fountain	Ripples, Green Evolutions, Agritech Services, Premier
78.	Multi-Vent	Multicolor
79.	Sanitary ware	Neycer Kermag (standard), Hindustan Sanitary Ware (1st quality), Parryware (superfine), Cera (1st quality), Classica (1st / standard)
80.	WC seat cover ISI Marked	Parryware, Neycer Kermag (standard), Hindustan Sanitary Ware (1st quality), Cera (1st quality), Classica (1st / standard)
81.	PVC Flushing Cistern IS: 774-1984 (ISI Certified)	Parryware, Hindustan Sanitary Wares, Cera.
82.	Faucets & Taps, Stop Valves & Pillar Taps, Surgical basin mixer, Shower rose etc.	Gem, Parko, Parryware, HSW, Jaquar, Orient
83.	Kitchen Stainless Steel Sink	Diamond, Nirali, Neel Kanth, Jayna
84.	Looking Mirror	Saint Gobain, Modi Float, Triveni Float Glass, Crown, Atul, Ashai





**LAYING, INSTALLATION,
TESTING AND COMMISSIONING
OF 8” DIA. STEEL GAS PIPELINE
CONNECTIVITY IN PATAN GA**



TENDER DOCUMENT NO
REPL/SGL/STPL/009/22

Date: -28/11/2022



85.	Ready made Bathroom Cabinets	Commander Gratings (I) Pvt Ltd, Gratolite Cabinet, A-4 Sector Viii Noida-202701, Alpina, Cera.
86.	Float Valve	Leader, Bombay Metal & Alloy Co, Bombay superflow.
87.	SGSW Pipes (IS-651) ISI Marked	Perfect Agra, Devraj Ind Gaziabad, Buran, RK, Prince, Supreme pipe and Fittings.
88.	CI (Centrifugally Cast) Pipes for sewage disposal ISI marked	NICCO, SRIF, A-1 Singhal Casting Co Agra, Jindal Saw, Kesoram, NECO
89.	PVC rain water/sewage pipes (IS-4985)	Reliance, Finolex, Supreme, Kisan, Prince, Hindustan Plastic & machine corporation, Polypack industries (P)Ltd.
90.	HDPE Water storage tanks (Rotational Moulded)	Sintex, Swift, Nutech, Sheetal
91.	Cast Iron Pipes and Fittings	Hindustan Engineering Products Company Calcutta, S..L.C., Standard approved manufacturers of any other brand of fittings having ISI marking, RIF, BIS
92.	RCC Pipes	Indian Hume Pipe Company, Delhi / Allahabad / Chandigarh / Lucknow; Hindustan Pressure Pipes, Kolhapur; Dhare Concrete Products, Pune or any other approved manufacturer conforming B.I.S. Standard
93.	Brass Fittings	Leader Engineering Works, Jalandhar; L & K Mathura; Luster Sanitary, Jalandhar; Annapurna Metal Works, Calcutta; Neta Metal Works, Jalandhar; Honey Industrial Corporation, Bombay.
94.	C.P. Fittings	Ego Metal Works, Ballabgarh; Jaquar Industries, Delhi; Soma Plumbing Fixtures Limited, Calcutta; Gem Sanitary Appliances Pvt. Ltd., Delhi; Essco Sanitations, Delhi; Bilmnet, Bombay.
95.	Stone Ware (Salt-Glazed) Pipes	Hind Ceramics Limited, Orissa; Ceramic Industries Limited, Sambalpur; Shrikamakshi Agencies, Madras; Binary Udyog Pvt. Limited, Howrah; Tirumati Moulds Limited, Nagpur; Kiran Potteries, Hyderabad; Perfect Sanitary Pipes, Bharatpur.
96.	Asbestos Cement Pipes and Fittings	Ganga Asbestos Limited, U.P.; Hyderabad Asbestos Cement Products Limited; J.K. Super Pipe Industries, Nanded; Konark Cement and Asbestos Limited, Orissa; Maharashtra Asbestos Limited, Bombay; Poddar Industrial Corporation, Patna; Sarbamangala Mfg. Company, Calcutta

	LAYING, INSTALLATION, TESTING AND COMMISSIONING OF 8” DIA. STEEL GAS PIPELINE CONNECTIVITY IN PATAN GA	
TENDER DOCUMENT NO REPL/SGL/STPL/009/22		Date: -28/11/2022

97.	HDPE pipes and fittings	ORI-PLAST,HASTI
-----	-------------------------	-----------------



23.0 MATERIALS NOT SPECIFIED

Any materials not fully specified in these specification and which may be offered for use in the works shall be subject to approval of Engineer, without which it shall not be used anywhere in the construction works.

	LAYING, INSTALLATION, TESTING AND COMMISSIONING OF 8” DIA. STEEL GAS PIPELINE CONNECTIVITY IN PATAN GA	
TENDER DOCUMENT NO REPL/SGL/STPL/009/22		Date: -28/11/2022



SPECIFICATION FOR CIVIL WORKS

PART – II WORKMANSHIP



	LAYING, INSTALLATION, TESTING AND COMMISSIONING OF 8” DIA. STEEL GAS PIPELINE CONNECTIVITY IN PATAN GA	
TENDER DOCUMENT NO REPL/SGL/STPL/009/22		Date: -28/11/2022

CONTENTS



1.0	GENERAL
1.1	Standard
1.2	Supervision
1.3	Temporary Works
1.4	Codes
1.5	Base Lines and Bench Marks
1.6	Setting Out
1.7	Dewatering
1.8	Safety of Existing Work
1.9	Protection of Existing Services
1.10	Handing Over of Work Site
2.0	EARTH WORK
2.1	Scope
2.2	General
2.3	Setting Out
2.4	Site Clearance and demolition
2.5	Classification of Soil
2.6	Method of Excavation
2.7	Excavation of Soils Other than Hard Rock
2.8	Excavation in Hard Rock
2.9	Cutting and Filling for Site Levelling

	LAYING, INSTALLATION, TESTING AND COMMISSIONING OF 8" DIA. STEEL GAS PIPELINE CONNECTIVITY IN PATAN GA	
TENDER DOCUMENT NO REPL/SGL/STPL/009/22		Date: -28/11/2022



- 2.10 Excavation for Trenches
- 2.11 Excavations for Foundations
- 2.12 Excess Excavation
- 2.13 Disposal of Excavated materials
- 2.14 Backfilling of Trenches
- 2.15 Backfilling of Foundations
- 2.16 Filling Under Floors
- 2.17 Load Bearing Fills
- 2.18 Turfing
- 3.0 **ANTI-TERMITE TREATMENT**
- 3.1 Scope
- 3.2 Execution
- 3.3 Acceptance Criteria
- 4.0 **CONCRETE (PLAIN & REINFORCED)**
- 4.1 Scope
- 4.2 Materials
- 4.3 Grades of Concrete
- 4.4 Mix Design
- 4.5 Water/Cement Ratio
- 4.6 Workability
- 4.7 Durability
- 4.8 Trial Mixes

	LAYING, INSTALLATION, TESTING AND COMMISSIONING OF 8” DIA. STEEL GAS PIPELINE CONNECTIVITY IN PATAN GA	
TENDER DOCUMENT NO REPL/SGL/STPL/009/22		Date: -28/11/2022



- 4.9 Nominal Mix Concrete
- 4.10 Volumetric Mix concrete
- 4.11 Batching of Concrete
- 4.12 Water
- 4.13 Mixing and Transportation of Concrete
- 4.14 Preparatory Works/Surface Preparation
- 4.15 Placing and Compaction of Concrete
- 4.16 Construction Joint & Cold Joints
- 4.17 Requirements for Concreting in Special cases
- 4.18 Finishes to Exposed Surfaces of Concrete
- 4.19 Curing of Concrete
- 4.20 Testing of Concrete
- 4.21 Steel Reinforcement
- 4.22 Shuttering
- 4.23 Damp Proof Course Concrete
- 4.24 Grout
- 4.25 Concreting in Water Retaining Structures
- 4.26 Application of Live Load
- 4.27 Foam Concrete
- 5.0 **MASONRY**
- 5.1 General

	LAYING, INSTALLATION, TESTING AND COMMISSIONING OF 8” DIA. STEEL GAS PIPELINE CONNECTIVITY IN PATAN GA	
TENDER DOCUMENT NO REPL/SGL/STPL/009/22		Date: -28/11/2022

- 5.2 Materials
- 5.3 Selection of Mortars
- 5.4 Cement Mortar
- 5.5 Brick work
- 5.6 Stone masonry
- 5.7 Hollow Concrete Block Masonary
- 6.0 **PLASTERING AND POINTING**
- 6.1 Materials
- 6.2 Plastering
- 6.3 Cement Pointing
- 6.4 Rough Cast Concrete Facing
- 6.5 Punning with Lime or Plaster of Paris
- 7.0 **FLOORING, PAVING & FACING**
- 7.1 Scope
- 7.2 Materials
- 7.3 General
- 7.4 Sub-base
- 7.5 Subgrade
- 7.6 Cement Concrete Flooring with Integral Finish
- 7.7 Concrete Flooring with Granolithic Finish (Artificial Stone Flooring)
- 7.8 Dado & skirting Work (Grey Cement Skirting / Dado)

	LAYING, INSTALLATION, TESTING AND COMMISSIONING OF 8” DIA. STEEL GAS PIPELINE CONNECTIVITY IN PATAN GA	
TENDER DOCUMENT NO REPL/SGL/STPL/009/22		Date: -28/11/2022

- 7.9 Flooring & Facing with Redoxide of Iron (Red Artificial Stone Flooring)
- 7.10 Terrazzo Flooring & Facing
- 7.11 Glazed Tile Finished Flooring & Facing
- 7.12 Marble Flooring
- 7.13 Marble in Facia or Dado
- 7.14 Flooring/Paving with Hardener like Ironite.
- 7.15 Chemical resistant tile flooring/facing
- 7.16 Chemical resistant In-Situ Finished Flooring / Facing
- 7.17 Acceptance Criteria
- 8.0 **WOOD WORK**
- 8.1 General
- 8.2 Joinery
- 8.3 Shrinkage & Tolerance
- 8.4 Fixing
- 8.5 Tarring
- 8.6 Fittings
- 8.7 Doors
- 8.8 Panelled Shutters
- 8.9 Glazed Shutters
- 8.10 Flush Door Shutters
- 8.11 Other type of shutters

	LAYING, INSTALLATION, TESTING AND COMMISSIONING OF 8" DIA. STEEL GAS PIPELINE CONNECTIVITY IN PATAN GA	
TENDER DOCUMENT NO REPL/SGL/STPL/009/22		Date: -28/11/2022

8.12 Inspection

9.0 METAL DOORS, WINDOWS AND ROLLING SHUTTERS

9.1 General

9.2 Fixing

9.3 Fittings

9.4 Normal Steel Plate Doors

9.5 Pressed Steel Doors

9.6 Steel Windows, Sashes, Ventilators, etc.,

9.7 Collapsible Gate (Steel)

9.8 Steel Rolling Shutters and Grills

9.9 Guarantee

9.10 Aluminium Doors, Windows, Frames

10.0 GLAZING

10.1 General

10.2 Doors, Windows and Ventilators.

10.3 Northlight Glazing

11.0 WHITE WASHING, COLOUR WASHING & PAINTING



11.1 Scope

11.2 Materials



11.3 White Washing, Colour Washing

11.4 Cement Primer Coat



11.5 Water Proof Cement Paint

	LAYING, INSTALLATION, TESTING AND COMMISSIONING OF 8" DIA. STEEL GAS PIPELINE CONNECTIVITY IN PATAN GA	
TENDER DOCUMENT NO REPL/SGL/STPL/009/22		Date: -28/11/2022



- 11.6 Oil Bound distemper
- 11.7 Dry Distemper
- 11.8 Plastic Emulsion Paint
- 11.9 Bitumen Painting
- 11.10 Tarring
- 11.11 Painting to Timber & Steel Surface
- 12.0 **INTERNAL WATER SUPPLY, PLUMBING, DRAINAGE AND SANITATION**
- 12.1 Scope of work
- 12.2 Water Supply & Plumbing
- 12.3 Drainage and Sanitation (Internal)
- 13.0 **EXTERNAL SEWERAGE & DRAINAGE**
- 13.1 Scope of work
- 13.2 Materials
- 13.3 Excavation of trenches and pits
- 13.4 Cast Iron pipes
- 13.5 Stone ware glazed pipelines (S.W.G)
- 13.6 Man holes
- 13.7 Marker plates
- 14.0 **ROAD WORK**
- 14.1 General
- 14.2 Trenching and Preparation of Subgrade

	LAYING, INSTALLATION, TESTING AND COMMISSIONING OF 8” DIA. STEEL GAS PIPELINE CONNECTIVITY IN PATAN GA	
TENDER DOCUMENT NO REPL/SGL/STPL/009/22		Date: -28/11/2022

- 14.3 Ash Carpet
- 14.4 Boulder Soling
- 14.5 Kerbs
- 14.6 Water Bound Macadam Surfacing
- 14.7 Preparation of Base and Shoulders
- 14.8 Spreading Coarse Aggregates
- 14.9 Rolling
- 14.10 Application of Screenings
- 14.11 Sprinkling and Grouting
- 14.12 Application of Binding Material
- 14.13 Setting and Drying
- 14.14 Surface Evenness
- 14.15 Bituminous Pavements
- 14.16 Berms
- 14.17 Kerbs
- 14.18 Bridges and Culverts
- 14.19 Boulder Pitching
- 14.20 Scarifying & Dismantling
- 14.21 Diversions
- 15.0 **WATERPROOFING TO ROOFS & BASEMENTS & WATER PROOFING PAINTS**
- 15.1 Scope

	LAYING, INSTALLATION, TESTING AND COMMISSIONING OF 8” DIA. STEEL GAS PIPELINE CONNECTIVITY IN PATAN GA	
TENDER DOCUMENT NO REPL/SGL/STPL/009/22		Date: -28/11/2022

- 15.2 Material
- 15.3 General Workmanship
- 15.4 Painting with Hot Bitumen
- 15.5 Painting with Bitumen Emulsion
- 15.6 Waterproofing of Roof
- 15.7 Waterproofing for Basement
- 15.8 Surface Application
- 15.9 Guarantee
- 15.10 Waterproofing course with fibre glass R.P. tissue.
- 15.11 Waterproofing course with PVC sheets/membrane
- 15.12 Waterproofing with Non-shrink polymeric waterproof grouting compound.
- 16.0 MISCELLANEOUS
- 16.1 False Ceiling
- 16.2 Wall Panelling & Wooden Partition
- 16.3 Expansion and Isolation Joints
- 16.4 Barbed Wire Fencing
- 16.5 Concertina Coil Fencing

	LAYING, INSTALLATION, TESTING AND COMMISSIONING OF 8” DIA. STEEL GAS PIPELINE CONNECTIVITY IN PATAN GA	
TENDER DOCUMENT NO REPL/SGL/STPL/009/22		Date: -28/11/2022

1.0 GENERAL

1.1 Standard

A high standard of workmanship in all trades will be required. The Contractor shall ensure that only skilled and experienced workmen are employed.

1.2 Supervision

The Contractor's supervising staff shall be fully qualified and experienced in the types of work being carried out under their supervision and shall be capable of ensuring that work is executed efficiently and as per specification.

1.3 Temporary works

Where required, the Contractor shall furnish such details of his temporary works as may be called for by the Engineer and the Contractor shall satisfy the Engineer as to their safety and efficiency. The Engineer may direct that temporary works, which he considers unsafe or insufficient, shall be removed and replaced in a satisfactory manner.

1.4.0 Codes



1.4.1

The years of publication against various standards, referred in this specification, correspond to the latest standards as on date of preparation of this specification. During use of this specification in future, the latest publication as on date shall be referred to. Where standards are not yet published by the BIS or IRC, adoptable British Standards or other International Standards shall apply.

In case of any conflict in meaning between these specifications and those of BIS or IRC, or British/International Standards, the provisions of these specifications shall prevail.

1.5 Base lines and bench marks

The Contractor shall establish and maintain, to the satisfaction of Engineer, the base lines and bench marks, based on which the works are set out. Where such base lines and bench marks are provided by

	LAYING, INSTALLATION, TESTING AND COMMISSIONING OF 8” DIA. STEEL GAS PIPELINE CONNECTIVITY IN PATAN GA	
TENDER DOCUMENT NO REPL/SGL/STPL/009/22		Date: -28/11/2022

the Engineer, the Contractor shall maintain these throughout the period of construction without causing any disturbance to them.

1.6 Setting out

The Contractor shall set out all the works to be executed by him, in line with the standard base lines, levels, position and bench marks and truly as per drawings within the accepted tolerance limits at no extra cost to Owner. The Contractor shall be solely responsible for the setting out of all the works, to be executed by him and the approval of such setting out by the Engineer shall in no way absolve the Contractor his responsibility for carrying the work to the true lines, levels and positions as per drawings.

1.7 Dewatering

The Contractor shall carry out all the works, in dry and workable condition and maintain the same in dry condition till the final handing over of works at no extra cost to the Owner. For this the Contractor shall make all the necessary provisions of dewatering, wherever necessary, to the entire satisfaction of the Engineer.

1.8 Safety of existing work



Before taking up any construction adjoining other property or existing work, the Contractor shall take all steps necessary for the safety and protection of such property or work at no extra cost to the owner.

1.9 Protection of existing services

The Contractor shall take all precautions necessary to prevent damage to or interference with underground or overground services such as cables, drains, piping or piles, whether shown on drawings or not. Equipment etc., mounted in position shall be protected against falling debris etc., by means of tarpaulin or such other material at no extra cost to the owner.

1.10 Handing over of work site

On completion of work, the Contractor shall remove all rubbish, debris,

	LAYING, INSTALLATION, TESTING AND COMMISSIONING OF 8” DIA. STEEL GAS PIPELINE CONNECTIVITY IN PATAN GA	
TENDER DOCUMENT NO REPL/SGL/STPL/009/22		Date: -28/11/2022

surplus materials, temporary work etc., from the site. The site shall be handed over in a tidy and workmanlike manner at no extra cost to the owner.

2.0 EARTH WORK

2.1 Scope

This chapter deals with earth work and excavation for civil works in site, formation/oversite leveling, foundations, cutting and grading for roads/pavement and railways, canals, embankments other than water retaining embankments trenching for drainage and other burried services and the like.

2.2 General



The Contractor shall carry out the excavation strictly to the lines and levels, in conformity with the drawings or instructions of the Engineer.

2.3 Setting out

Before commencement of earthwork block levels of existing ground shall be taken by the Contractor jointly with the Engineer, plotted and signed in token of acceptance of ground levels. Excavation shall not be commenced until the initial ground levels have been recorded and accepted. Reference lines, bench marks and base lines shall be set out by the Contractor for control of earthwork operation. Setting out shall be done with pegs, blocks, bamboo poles or rails, marking boundaries or centre lines, as the case may be, and the same maintained for reference and future checking. Chainaie stones at regular intervals shall be set up for embankments. All setting out operations shall be got checked and approved by Engineer. However, such checking and approval by the Engineer shall in no way absolve the Contractor of his responsibilities for carrying out the work to the true lines, levels and positions as per drawing, and in case any error is noticed at any stage in the contractor's work, it shall be corrected/rectified by him without any cost to the Owner.

2.4 Site clearance and demolition

The site shall be cleared of all trees, stumps, roots, brush wood, bushes and other objectionable materials. Useful and saleable material, if any, shall be the property of the owner and shall be stacked

	LAYING, INSTALLATION, TESTING AND COMMISSIONING OF 8” DIA. STEEL GAS PIPELINE CONNECTIVITY IN PATAN GA	
TENDER DOCUMENT NO REPL/SGL/STPL/009/22		Date: -28/11/2022

properly as directed by the Engineer. The areas to be covered with embankments shall be stripped of top soil to required depths to expose acceptable founding strata. Top soil unsuitable for use in embankment construction and other fills shall be disposed off as directed. All combustible materials shall be stacked and burnt in locations sufficiently remote to eliminate all danger of fire hazards. All old concrete, brick works and drains which interfere with construction works shall be dismantled with the approval of the Engineer taking all necessary precautions prescribed in safety specification. Top soil which is suitable for use in construction work shall be stockpiled for later use. Other objectionable materials such as trash, debris, stones, brick, broken concrete, scrap metal etc., shall be disposed off as directed by the Engineer. Payment for cutting and removal of trees, stumps, dismantling existing structures and stripping shall be regulated by the description in the Schedule of Items or Part V of these specifications.

2.5 **Classification of soil**

The Engineer will decide the class of any particular soil. Classification of soil shall be as under and the decision of the Engineer shall be binding on the Contractor:



A) Ordinary Soil

Soils which yield to ordinary application of pick and shovel, phawra rake or other ordinary digging implements (including earth moving equipment such as bulldozer, shovels without resorting to blasting) without offering much resistance, shall be classified as ordinary soil. This includes organic soil, turf, sand, gravel, loam clay, mud, peat, black cotton soil, soft shale and loose moorum etc.

B) Hard Soil

This comprises of all soils that cannot reasonably be excavated by the above mentioned digging implements, but can be excavated with close application of pick axe or scarifiers or jumpers to loosen. This includes compact moorum, stiff clay, hard shale, cobble stone etc.,

C) Soft /Decomposed Rock

	LAYING, INSTALLATION, TESTING AND COMMISSIONING OF 8” DIA. STEEL GAS PIPELINE CONNECTIVITY IN PATAN GA	
TENDER DOCUMENT NO REPL/SGL/STPL/009/22		Date: -28/11/2022

This comprises of rock or boulders which may be quarried or split with crow bars, pavement breakers etc., This include lime stone, sand stone, weathered rocks and hard conglomerates etc .and existing structures embedded in earth and tarred macadam roads, pavements, met in the excavation. The fact that contractor resorts to blasting for his own reasons shall not mean that the rock is hard and classified as hard rock.

D) Hard Rock



This comprises of rocks which require blasting for excavation. Where blasting is prohibited, excavation has to be carried out by chiseling, wedging or any other agreed methods.

2.6 Method of excavation

The Contractor may carry out excavations, filling and compaction by any method considered most suitable, and befitting the site conditions subject to any stipulations contained in the contract and the specifications. All excavations shall be required to be kept completely free from water, from whatever source it may come, during the construction. No foundation work shall be taken up until the surfaces are properly drained.

2.7 Excavation of soils other than hard rock

Excavation shall be carried out in the most expeditious and efficient manner to the lines and levels as indicated in drawings or as directed by Engineer. Prior approval of the Engineer shall be taken for the method to be adopted for excavation including dimensions, side slopes, dewatering, shoring etc., Such approval shall not make the Engineer responsible for any consequent damage or loss caused. All precautions shall be taken to preserve the material below and beyond line of excavation in soundest condition. All damages done beyond limits of excavation shall be made good by the Contractor at his own cost in a manner approved by the Engineer. All excavated materials shall be removed to spoil heaps, dumping yards or transported for filling as may be necessary. When soil heaps are formed for future use, heaps shall be protected from washing away due to rain or surface run off. The sides of excavation shall be maintained in stable condition by adequate stepping and batter. To prevent entry of surface water and accumulation of subsoil water in excavated areas, suitable

	LAYING, INSTALLATION, TESTING AND COMMISSIONING OF 8” DIA. STEEL GAS PIPELINE CONNECTIVITY IN PATAN GA	
TENDER DOCUMENT NO REPL/SGL/STPL/009/22		Date: -28/11/2022

drainage arrangements as may be needed and directed by Engineer, shall be provided and maintained. Pumped out water shall be drained off properly avoiding damage to other existing works. If any pipelines, cables or service lines are likely to be exposed, excavation around these services shall be carried out manually and all such services shall be adequately supported and protected at no extra cost.



Excavation shall be carried out in any material encountered including road surfaces, pavements, buried parts of old foundations, pits or other structures. Excavated materials shall be placed beyond 1.5 metres of the edge of the excavation pit/trench or half the depth of the pit/trench whichever is more or further away as directed by the Engineer. Sumps made for dewatering must be kept clear of the foundations.

In firm soil the sides of the trenches shall be kept vertical upto a depth of 2.0m from the bottom and for a greater depth, trench shall be widened by allowing steps of 50cm on either side after every 2.0m depth from the bottom, so as to give a vertical side slope of 1/4 : 1. Where the soil is soft, loose or slushy, the width of the steps shall be suitably increased or sides suitably sloped or suitable shoring and strutting provided as directed by the Engineer. For trenches deeper than 2.0m, the Contractor shall obtain detailed instruction from the Engineer in writing regarding the stepping, sloping of sides or shoring and strutting to be done. For these bye-works, no extra cost will be paid to the Contractor.

2.8 Excavation in hard rock

Where hard rock is met and blasting is considered necessary for its excavation, the Contractor shall intimate the Engineer in writing. Excavation in hard rock shall be done either by blasting or chiseling or by such other agreed methods as may be required. Levels of hard rock surface shall be taken and got approved by Engineer before start of excavation. Blasting shall be permitted only when proper precautions are taken for protection of persons, works and property. The Contractor shall obtain the necessary licence for procuring, storing and using explosives.

Blasting operations shall be carried out by a licensed Blaster. The quality and quantity of explosives, size and spacing of holes depth of holes etc., shall be such that they will neither open seams nor damage or shatter the rock beyond the specified lines of excavation. A

	LAYING, INSTALLATION, TESTING AND COMMISSIONING OF 8" DIA. STEEL GAS PIPELINE CONNECTIVITY IN PATAN GA	
TENDER DOCUMENT NO REPL/SGL/STPL/009/22		Date: -28/11/2022

tolerance of 150 mm will however be allowed beyond the excavation lines. As excavation approaches final stages, the depth of holes and the amount of explosives used shall be reduced progressively to avoid over breakage or damage to founding strata. Any fissures, cracks and voids below prescribed depth of excavation shall be corrected by removing loose pieces, shattered or affected rock and replaced by lean concrete of M-5 grade or (1:5:10) cement concrete in the case of foundations. Where excavated surface is to receive structural concrete, the surface shall be cleaned of dust and other objectionable materials.



In cases where blasting, though otherwise required, is prohibited because of any reason, the excavation shall be carried out by chiseling, wedging or such other agreed methods. All materials excavated from blasting, chiseling or any such methods shall be stacked for measurement as directed by Engineer.

2.9 Cutting and filling for site leveling

Excavation and filling operations for site leveling shall be so planned and executed, that transportation and re-handling are minimised. The sides of excavation and fills shall be maintained in stable condition by adequate batters, stepping and dewatering. Materials not desirable shall be disposed off in area indicated by Engineer. When it is required to blend the material, it shall be done by selective excavation and filling operation. Wells, ponds, cesspools and water logged areas shall be emptied of water and deslushed before filling. Filling shall be done in horizontal layers not exceeding 300mm in thickness as specified or as directed by the Engineer. All clods shall be broken before placing the fill. Earth moving equipment shall be allowed to ply over the fill to permit compaction. Adequate allowance shall be made for subsidence of fill material. Levels shall be taken and excess or shortfall shall be made good by appropriate cutting or filling.

2.10 Excavation for trenches

Excavation for trenches shall be carried out in materials encountered to enable laying of service lines or drainage channels or any other desired purpose. Excavation shall be done to lines and levels shown in drawings and shall be done providing adequate measures for stability. Vertical wooden sleepers or light rails shall be erected at uniform levels at places where changes of direction and gradients occur. Centre lines shall be marked on horizontal sleepers or rails, laid across the

	LAYING, INSTALLATION, TESTING AND COMMISSIONING OF 8” DIA. STEEL GAS PIPELINE CONNECTIVITY IN PATAN GA	
TENDER DOCUMENT NO REPL/SGL/STPL/009/22		Date: -28/11/2022



trenches. Depths of excavation and pipe invert levels shall be checked by means of boning rods of appropriate lengths. Trench beds shall be trimmed and rammed with sprinkling of sand or moorum to required gradients for continuously supporting the pipelines. Trenches shall be locally deepened and widened to receive sockets and permit joints to be inspected.

Timbering

In case of trenches, tunnels, channels, drains, manholes, chambers, basement and other places where the soil is not capable of being retained without the support, timbering as directed by the Engineer shall be resorted to. It shall be the responsibility of the Contractor to take all the necessary steps to prevent the sides from collapsing.

2.11 Excavations for foundations

Excavation for foundation shall be done to the lines and levels indicated in the drawings. Excavated material shall be transported and stored at convenient spots for reuse in back filling of foundations and other fills. Surplus material shall be transported, spread and levelled at dumping areas. Side slopes of excavation and/or shoring shall be adequate from consideration of stability and working space. When so required and authorised by Engineer, the sides of excavation shall be protected with proper shoring, strutting, sheeting and sand bags etc., These shall be removed only when work in the pit is completed, with the approval of the Engineer. When it is felt that removal of supports may result in side collapse or settlement of adjoining ground or endanger adjoining structures and foundations, they shall be left permanently in position. The last 150 mm of excavation shall be done and the bottom trimmed to the required levels only when concreting is imminent. If at any point the natural ground is disturbed or loosened for any reason, it shall be consolidated by tamping or rolling or made up with concrete of M-5 grade, or (1:5:10) cement concrete if so ordered by the Engineer at no extra cost. Where the soil encountered at depths indicated in drawings is loose or weak, it shall be further excavated to levels of firm strata as may be directed by the Engineer and filled with lean concrete of M-5 grade/(1:5:10) cement concrete or sand as directed. If the bottom of excavation has been left exposed not through neglect or fault of the Contractor and it has become deleteriously affected by atmospheric action and water, such portion of deteriorated foundation material shall be removed and made good by lean concrete of grade M-5/(1:5:10) cement concrete or sand as

	LAYING, INSTALLATION, TESTING AND COMMISSIONING OF 8" DIA. STEEL GAS PIPELINE CONNECTIVITY IN PATAN GA	
TENDER DOCUMENT NO REPL/SGL/STPL/009/22		Date: -28/11/2022

directed and such extras will be paid for.

2.11.1 For deep excavation in the proximity of existing buildings, foundations, streets, railway tracks, underground cabling, gas piping, water and drainage lines, and the like, adequate appropriate precautions shall be taken to protect such structures or works from damage, displacement or settlement, either as an immediate result of the excavation or as after effect, discernible with the passage of time. The method of protection of existing structures and services may include sheet piling, shoring, strutting slinging or any other method including dewatering. Payment for such protective work shall be governed by the description given in the Schedule of Items for the particular work.

2.11.2 For excavation adjoining existing piles care shall be taken to ensure that no pile under any circumstances is exposed from the top for a height exceeding 2 metres. No strutting shall be done against exposed piles, nor exposed piles ever used for tying guy ropes or supports either temporarily or permanently.



2.12 Excess excavation

All excavation done beyond the specified limits or directions of Engineer shall be considered as excess excavation. They shall be made good as prescribed below by the Contractor at his cost:

- i) Excess excavation in case of site leveling shall be made good by filling and compacting with material same as the surrounding material. Degree of compaction shall be at least the same as the surrounding material.
- ii) Excess excavation in case of trenches shall be made good by filling and compacting with selected earth to the same compaction as the surrounding material or as directed by Engineer. This shall be done in layers not exceeding 150 mm thick, moistened and thoroughly compacted by tamping.
- iii) Excess excavation in case of foundation beyond required depths shall be made good by filling with lean concrete of M-5 grade/(1:5:10) cement concrete.

2.13 Disposal of excavated materials

Excavated materials that are unsuitable for use in construction works

	LAYING, INSTALLATION, TESTING AND COMMISSIONING OF 8” DIA. STEEL GAS PIPELINE CONNECTIVITY IN PATAN GA	
TENDER DOCUMENT NO REPL/SGL/STPL/009/22		Date: -28/11/2022

or in excess of construction requirements shall be disposed off in dumping yards or in locations indicated by Engineer. Waste piles/heaps shall be located in such places where they will not interfere with natural flow of rain water access or transport or with the access to nearby structures. When required, they shall be levelled and trimmed to such lines and levels as indicated by Engineer.

2.14 Back filling of trenches



Trenches shall be backfilled after pipes or service lines are tested and approved. Filling shall be done with earth in 150 mm thick layers free from unwanted material and well rammed. Soft material shall be used in bottom of trenches upto a level of 150 mm above the top of pipes before backfilling with other fill materials. All clods and lumps shall be broken before placement. Care shall be taken not to disturb, break or damage the pipes during backfilling and compaction process.

2.15 Backfilling of foundations

Backfilling of foundations shall be done using suitable soils from excavations. Soil shall be free from organic matter and other materials which would affect the stability of the fill and shall be free from boulders, brick bats wood pieces and other injurious materials, lumps and clods. Before commencement of backfilling of foundations. all shoring and formwork, bits of timber, cement bags and all other rubbish shall be removed. Hydro-insulation, Bitumen painting or application of anti-corrosive protective and anti-termite treatments shall have been completed. Backfilling operation shall not commence without approval of Engineer. Backfilling shall be carried out in well compacted layers of 150 mm thickness. Each layers shall have near optimum moisture content. Layers will extend to the entire width of excavation and shall be sprinkled with water during compaction process. Ramming shall be done to achieve firm compaction. Backfill shall be trimmed and finished to lines and levels indicated in the drawings and/or as directed by the Engineer. Mechanical equipment like vibratory roller, vibro earth rammer or vibratory compactor shall be used for compaction.

2.16 Filling under floors

Material for filling under floors shall be soil free from harmful minerals, vegetable matter etc., and shall not be expansive soils. Filling shall be done in well compacted layers not exceeding 150 mm in thickness. Each layer shall be compacted to 95% Standard Procter Density.

	LAYING, INSTALLATION, TESTING AND COMMISSIONING OF 8" DIA. STEEL GAS PIPELINE CONNECTIVITY IN PATAN GA	
TENDER DOCUMENT NO REPL/SGL/STPL/009/22		Date: -28/11/2022



Sufficient soaking shall be done before compaction. The entire area to be covered by flooring shall be finally dressed and trimmed to required levels. Mechanical equipment like vibratory roller, vibro earth rammer or vibratory compactor shall be used for compaction.

2.17 Load bearing fills

Load bearing fills include embankments for roads and railways and such other earth fills above ground levels provided for protection of fuel oil tanks, pads for storage tanks, drain, bunds and the like. Fill materials shall either be selected earth obtained from excavations for site leveling, trenches and foundations or from selected borrow areas as may be required. Soils selected for filling in embankments shall be of uniform quality and free from boulders, organic materials and other objectionable matter. Soils having high silt and clay content and having laboratory maximum dry density less than 1.44 gms per c.c. shall not be used for load bearing fills. For fills greater than 3 m in height soils shall have laboratory density not less than 1.52 gms per c.c. Soils for top 500 mm of fills for roads and railways shall have laboratory density not less than 1.65 gms per c.c. and shall not have marked swelling and shrinkage properties.

Foundation preparation for embankments shall be done as prescribed under site clearance. The founding strata shall be compacted as much as possible by rolling or tamping before placement of fill material. The water content of founding strata should be same as that specified for embankment fill. Any pockets of loose material or depressions left in founding strata as a result of clearing operation shall be filled and compacted with the same material as the surrounding founding strata. When an embankment is to be placed on steep sloping ground the surface of the ground shall be trenched in steps or trenched or broken up in such a manner that the new materials bonds well with the founding strata.

Fill material shall not be placed until foundation has been inspected and approved by Engineer. Material shall be placed in even, continuous, horizontal layers over full width of embankment in well compacted layers not exceeding 200 mm thickness. Each layer shall be compacted by means of smooth rubber tyred rollers, sheep-foot rollers, tractors, tampers or other mechanical means as may be found suitable for the location. Before rolling, the water content shall be checked and corrected by sprinkling with water or adding dry material or aeration as may be required. This shall be followed by mixing and

	LAYING, INSTALLATION, TESTING AND COMMISSIONING OF 8" DIA. STEEL GAS PIPELINE CONNECTIVITY IN PATAN GA	
TENDER DOCUMENT NO REPL/SGL/STPL/009/22		Date: -28/11/2022

the layer left for soaking before compaction. The water content shall be within plus or minus 2% of Standard Proctor Optimum. Density of compacted layers shall be determined by sand replacement method. Average compacted density shall be at least 95% of Standard Proctor Density. The number of tests to be conducted for determination of moisture content and density shall be as prescribed by the Engineer. Side slopes of embankments shall be formed along with the main embankment. No side dumping shall be done for the formation of slopes. When required the width of each layer shall be constructed slightly in excess of required width and slopes trimmed to remove loose edge materials and completed to lines shown in drawings or as directed by the Engineer. Subgrades for road works shall be thoroughly wetted sufficiently in advance of placing of any base course and it shall be ensured that it is firm and moist for at least 50 mm below the surface. Should the subgrade for any reason be loose or have density less than required, it shall be recompacted and refinished. Excessive loss of moisture in the subgrade shall be prevented by sprinkling and/or scaling. No traffic or hauling equipment shall be permitted to ply on finished subgrade and any damage caused to such portion shall be made good by the Contractor at his own cost.

2.18 Turfing



The slopes of embankment shall be dressed to line and slightly roughened to bond and hold a surface dressing consisting of 150 mm humus layer of soil. The entire surface shall then be covered with turf consisting of blocks or strips of grass of approved species. The sod shall include a net of roots and earth at least 75 mm thick. The sod shall be laid on slope in close contact and then tamped in place so as to close and fill the joints between blocks.

Immediately after placing the turf, slope shall be thoroughly wetted and kept wet for a sufficient period to assure plant growth. Watering shall be continued until the grass takes root firmly and the whole area presents a uniform appearance. In the event that the plant growth has not taken place within the period of maintenance such areas or patches shall be redone by the Contractor at his own cost.

3.0 ANTI-TERMITE TREATMENT

3.1 Scope

The scope of work includes setting up a chemical barrier against attack

	LAYING, INSTALLATION, TESTING AND COMMISSIONING OF 8" DIA. STEEL GAS PIPELINE CONNECTIVITY IN PATAN GA	
TENDER DOCUMENT NO REPL/SGL/STPL/009/22		Date: -28/11/2022

by subterranean termites while the building is under construction.

3.2 Execution

3.2.1 General

Unless otherwise specified all work shall in general be executed as specified in IS : 6313 Part-II -1981 and as per approved specification of the agency having special know-how for the job.

All necessary work to ensure uniform distribution and proper penetration of treating solution shall be done according to the instruction of the Engineer.

Soil treatment shall not be done when it is raining or when the soil is wet with rain or subsoil water. Once formed, the treated soil barrier shall not be disturbed.

3.2.2 Chemicals and rate of application



Chemical like chlorpyriphos 20% EC (Conforming to IS 8963 - 1978) in 1% emulsion shall be applied by pressure pumps, uniformly over the area treated. (1 part chemicals + 20 parts water = 1% emulsion).

3.2.2.1 Treatment of pits, trenches & basement excavations

Foundations, basements etc. may either be fully enveloped by the chemical barrier or the treatment may start 500 mm below ground level. The bottom surface and sides of excavation (upto a height of about 300mm) for column pits, walls, trenches and basements shall be treated with emulsion @ 5 liters per sq.m. of surface area. Backfills around columns, walls, etc., shall be treated @ 7.5 liters per sq.m. of the vertical surface. Treatment shall be done in stages following the compaction of earth in layers. The treatment shall be carried out after the ramming operation is done by rodding the earth at 150mm centers closed to the wall surface and spraying the emulsion in the specified dose.

3.2.2.2 Treatment of top surface of plinth filling

Holes 50 mm to 75 mm deep at 150 mm centres both ways shall be made with crow-bars on the surface of compacted plinth fill. Emulsion at the rate of 5 litres per sq.m of surface shall be applied prior to laying

	LAYING, INSTALLATION, TESTING AND COMMISSIONING OF 8” DIA. STEEL GAS PIPELINE CONNECTIVITY IN PATAN GA	
TENDER DOCUMENT NO REPL/SGL/STPL/009/22		Date: -28/11/2022

soling or subgrade. Special care shall be taken to maintain continuity of the chemical barrier at the junction of vertical and horizontal surfaces.

3.2.2.3 Treatment of doors, windows & soil surrounding pipes, Wastes and conduits.

Special care shall be taken at the points where pipes and conduits enter the building and the soil shall be treated for a distance of 150 mm and a depth of 75 mm at the point where they enter the building. All the wooden door/window frames on the ground floor of the buildings shall be treated with the insecticidal solution.

3.2.2.4 Treatment of expansion joints

These shall receive special attention and shall be treated in a manner approved by the Engineer.

3.3 Acceptance Criteria



The Contractor shall give a 10 year service guarantee in writing supplemented by a separate and unilateral guarantee from the specialised agency for the job to keep the building free of termites for the specified period at no extra cost to the Owner.

4.0 CONCRETE PLAIN & REINFORCED

4.1 Scope

This chapter covers the workmanship, special requirements & regulations with which the contractor must comply to achieve the following two objectives :

- (a) The provision, at all locations on the site, of dense workable concrete, having the specified characteristic strength.
- (b) The placing of concrete at all elevations, well compacted by vibrations, in well aligned and well fixed formwork ensuring the

	LAYING, INSTALLATION, TESTING AND COMMISSIONING OF 8" DIA. STEEL GAS PIPELINE CONNECTIVITY IN PATAN GA	
TENDER DOCUMENT NO REPL/SGL/STPL/009/22		Date: -28/11/2022

internal and external dimensions of structures as per drawings and maintaining the size, shape number and locations of reinforcements, inserts etc., as specified in the drawings providing the surface finish after stripping off the formwork to ensure the structural configurations as per drawings as well within the specified tolerance limits, curing and guaranteeing the characteristic strength, all as specified.

- 4.1.1 The mixing, placing, compacting, curing and finishing of concrete shall be done according to IS: 456-1978 "Code of Practice for Plain and Reinforced Concrete".

4.2 Materials

For materials, reference to Part - I (Materials) shall be made.

4.3 Grades of Concrete

The grades of concrete unless otherwise specified shall be in accordance with the following table. The grade of concrete to be used in each section of work will be shown in the drawings or in the schedule of items :

Grade of Concrete	Characteristic Strength i.e. Compressive Strength of 15 cm cubes at 25 days (N/mm ²)	Nominal Maximum Aggregate Size (mm)
M-5A	5	63
M-5B	5	40
M-7.5A	7.5	63
M-7.5B	7.5	40
M-10A	10	63
M-10B	10	40
M-10C	10	20



**LAYING, INSTALLATION,
TESTING AND COMMISSIONING
OF 8" DIA. STEEL GAS PIPELINE
CONNECTIVITY IN PATAN GA**





**TENDER DOCUMENT NO
REPL/SGL/STPL/009/22**

Date: -28/11/2022

Grade of Concrete	Characteristic Strength i.e. Compressive Strength of 15 cm cubes at 25 days (N/mm ²)	Nominal Maximum Aggregate Size (mm)
M-10D	10	12
M-15A	15	63
M-15B	15	40
M-15C	15	20
M-15D	15	12
M-20A	20	63
M-20B	20	40
M-20C	20	20
M-20D	20	12
M-25C	25	20
M-25D	25	12
M-30C	30	20
M-30D	30	12
M-35C	35	20
M-35D	35	12
M-40C	40	20
M-40D	40	12

Notes : A,B,C,D mentioned along with grade of concrete correspond to the maximum size of coarse aggregate being 63mm, 40mm, 20mm & 12mm respectively.

	LAYING, INSTALLATION, TESTING AND COMMISSIONING OF 8" DIA. STEEL GAS PIPELINE CONNECTIVITY IN PATAN GA	
TENDER DOCUMENT NO REPL/SGL/STPL/009/22		Date: -28/11/2022

Unless otherwise specified in the drawings or schedule of items the maximum nominal size of coarse aggregates for different grades of concrete shall be as under :

a)	For concreting in very narrow space or in very small thickness	12 mm
b)	For all reinforced concrete work except in massive foundations	20 mm
c)	For all ordinary plain concrete & massive reinforced foundations	40 mm & 63 mm



4.4 **Mix Design**

4.4.1 **General**

At the commencement of the contract the Contractor shall make preliminary tests to determine the proportions by weight of cement, fine aggregates, coarse aggregates and water necessary to produce required grades of concrete. The mix proportions shall be selected to ensure that workability of the fresh concrete is suitable for the conditions of handling and placing and when concrete hardens, it shall have the required strength, durability and surface finish. The Contractor shall get approval of Engineer to such proportions before he starts concreting. However, such approval shall not relieve the Contractor of his responsibility to produce concrete having compressive strengths as laid down in the foregoing Table.

No departure from the approved proportions will be permitted during the works unless and until the Engineer gives written authorisation for any change in proportion. The Engineer shall have authority at any time to check whether the mixing of concrete is being carried out according to the approved proportions.

4.4.2 For the all major and important R.C. works and for all special works, the design of mixes shall be made by the Contractor at his own cost, for each grade of concrete as well as for various workability. The design of mixes shall be made according to I.S. 10262-1982 or any other approved standard methods.

	LAYING, INSTALLATION, TESTING AND COMMISSIONING OF 8” DIA. STEEL GAS PIPELINE CONNECTIVITY IN PATAN GA	
TENDER DOCUMENT NO REPL/SGL/STPL/009/22		Date: -28/11/2022

4.4.3 The concrete made by designing the mix is termed hereinafter as "Design Mix Concrete".

4.4.4 The cement content for various grades of concrete shall be based on design mix. However, irrespective of requirement of cement found out from design mix, the minimum cement content & maximum cement content of concrete shall be in accordance with Clause No. 8.2.4.1 & Clause No. 8.2.4.2 of I S 456 -2000 respectively.

4.5 **Water/Cement Ratio**

4.5.1 Where a particular water/cement ratio is stipulated in the design or drawing along with the characteristic grade of concrete the design of mix shall be carried out by adjusting the other variable factors to obtain the characteristic strength of concrete with stipulated water/cement ratio.



4.5.2 In the structures where the impermeability and shrinkage of concrete have an important bearing on the durability and serviceability of the structures, such as water retaining structures, basements, underground premises, tunnels, pump houses, exposed structures near sea side or deserts, prestressed structure, thin precast members etc. the water cement ratio shall be kept low and preferably not exceeding 0.45.

4.5.3 The water cement ratio, as achieved in the Mix Design, or as specified in the drawings shall be adhered to strictly and shall not be varied without the permission of the Engineer.

4.6 **Workability**

4.6.1 The workability of fresh concrete shall be such that the concrete is just suitable for the conditions of handling & placing so that after compaction it becomes completely consistent and homogeneously surrounds all the reinforcement and completely fills the formwork.

4.6.2 The workability of fresh concrete at the place of batching/mixing shall be measured by compacting factor test and at the place of disposition by means of slump test. During the finalisation of Trial Mixes, the relationship between compacting factor and slump test shall be established for each grade of concrete as well as for various levels of workability. The workability tests shall be carried out in accordance with

	LAYING, INSTALLATION, TESTING AND COMMISSIONING OF 8" DIA. STEEL GAS PIPELINE CONNECTIVITY IN PATAN GA	
TENDER DOCUMENT NO REPL/SGL/STPL/009/22		Date: -28/11/2022

IS:1199-1959.

4.6.3 Normally, in the condition of low water cement ratio as well as for medium/high workability, the workability shall be achieved by increasing the cement content, in consistent with added water.



4.6.4 In cases where the cement content is to be limited to reduce the heat of hydration, and the water/cement ratio is also to be kept low to reduce the permeability or due to other requirements the desired workability may be achieved with use of limited doses of plasticiser or air entraining agent. In such cases the method of mixing and dosage of the plasticiser/air entraining agent shall be according to the manufacturer's specification and with the approval of the Engineer.

4.6.5 The usual limits of consistency for various types of structures are given below :

Limits of consistency

Degree of Workability	Slump in mm with Standard - Cone		Use for which concrete is suitable as per IS : 1199
	Minimum	Maximum	
Very low	0.0	25.0	Large mass concrete Structure with heavy compaction equipment,roads and the like.
Low	25.0	50.0	Uncongested wide and shallow R.C.C structures
Medium	25.0	75.0	Deep but wide R.C.C structures with congestion of reinforcement and inserts
High	75.0	125.0	Very narrow and deep R.C.C structures with congestion due to reinforcement and inserts

Note : Not withstanding any thing mentioned above, the slump to be obtained for work in progress shall be as per direction of the Engineer. With the permission of the Engineer, for any grade of concrete, if the water has

	LAYING, INSTALLATION, TESTING AND COMMISSIONING OF 8” DIA. STEEL GAS PIPELINE CONNECTIVITY IN PATAN GA	
TENDER DOCUMENT NO REPL/SGL/STPL/009/22		Date: -28/11/2022



to be increased in special cases, cement shall also be increased proportionately to keep the ratio of water to cement same as adopted in trial mix design for each grade of concrete. No extra payment will be made for this additional cement.

4.7 Durability

The durability of concrete, depending on the exposure condition, is to be taken into account while designing the mix. For given aggregates, the cement content should be sufficient to make sufficiently low water cement ratio and Appendix A of IS: 456-1978 shall be taken as guideline for durability considerations.

4.8 Trial Mixes

- 4.8.1 After approval of the Mix Design by the Engineer, the Contractor shall make in presence of Engineer the Trial Mixes for each grade of concrete as well as for required workability.
- 4.8.2 Before starting the trial mixes, necessary preparatory works like sieve analysis of the aggregates, determination of densities of different ingredients and moisture contents in the aggregates, shall be completed according to the I.S. Codes 383-1970 and 2386-1963.
- 4.8.3 Each trial mix shall be handled and compacted by the method which the Contractor proposes to use for that mix in the works and the mixes shall not show tendency of inadequate compaction by the method proposed.
- 4.8.4 The compacting factor and the slump of each trial mix shall be determined immediately after mixing and the values shall not exceed the maximum value obtained in the mix design.
- 4.8.5 Six numbers of 150 mm test cubes shall be made from each trial mix. These shall be cured and tested in accordance with relevant I.S. codes. In order to have the specified characteristic strength in the field, the concrete mix as designed in the Design Mix shall have higher average compressive strength depending on the degree of quality control at site. If the size and special requirement of the work so warrants, the trial may be extended to cover larger ranges of mix proportions as well as other variables such as alternative source of aggregates, maximum size and grading of aggregates and different type and brands of cement.

	LAYING, INSTALLATION, TESTING AND COMMISSIONING OF 8” DIA. STEEL GAS PIPELINE CONNECTIVITY IN PATAN GA	
TENDER DOCUMENT NO REPL/SGL/STPL/009/22		Date: -28/11/2022

4.8.6 Before commencement of the concreting works of particular grade of concrete, the Contractor must complete the work of trial mixes and subsequent testing of the test cubes obtained therefrom the design of the Approved Mix for that particular grade of concrete.

4.8.7 The entire cost of all the trial mixes including all the preparatory works for trial mixes, preparation of test cubes and their testing shall be borne by the Contractor.

4.9 Nominal Mix Concrete

4.9.1 Nominal mix concrete may be used for all concrete of Grade M-10 and below. If design mix concrete cannot be used for any reason for Grade M-15 & M-20, nominal mix concrete may be used with the permission of Engineer, Nominal mix concrete shall not be used, in any case for Grade of concrete above M-20.

4.9.2 The proportioning of materials for nominal mix concrete shall be in accordance with Table-3 of clause 8.3 of I.S. 456-1978. The stipulations of Clauses 8.3.1 & 8.3.2 of IS: 456-1978 shall also be taken into consideration.

4.10 Volumetric Mix Concrete



Where concrete is specified in volumetric proportions such as 1:4:8, 1:3:6, 1:2:4, 1:1 1/2:3, 1:1:2 etc., in the schedule of items, coarse and fine aggregates shall be measured by volume and cement by weight. The water cement ratio shall be within 0.45 to 0.70 depending upon the workability.

4.11 Batching of Concrete

4.11.1 Cement

Cement shall always be batched by weight. A separate weighing device shall be provided for weighing cement. Where the weight of cement is determined by accepting the weight per bag, number of bags shall be weighed separately to determine the average net weight of cement per bag and the same shall be checked regularly

4.11.2 Aggregates

	LAYING, INSTALLATION, TESTING AND COMMISSIONING OF 8” DIA. STEEL GAS PIPELINE CONNECTIVITY IN PATAN GA	
TENDER DOCUMENT NO REPL/SGL/STPL/009/22		Date: -28/11/2022

4.11.3 For both Design Mix concrete and Nominal Mix concrete, the aggregates (coarse and fine) shall be batched by weight.

4.11.4 In particular cases, or where weigh-batching is not possible proportioning by volume batching may be allowed by the Engineer, provided the Contractor guarantees the uniformity of aggregates through out the period of construction. For this purpose, the Contractor shall submit to the Engineer sufficient data indicating the weight/volume relationship of aggregates for different types of concrete and after such approval, periodic checks on the weight/volume relationship of the aggregates shall be made by the Contractor to the satisfaction of the Engineer. Where aggregates are moist and volume batching is adopted, allowance shall be made for bulking in accordance with I.S. 2386 (Part-III)-1963.

4.11.5 Suitable adjustments shall be made for the variation in the weight of aggregates due to variation in their moisture contents.

4.12 Water



4.12.1 Water may be measured either by weight or by volume. When measured by volume, it shall be by well calibrated conical shaped jar or vessel or from a calibrated tank fitted to the mixer.

4.12.2 Adjustment of water due to moisture contents in coarse and fine aggregates

It is very important to maintain the water cement ratio constant at its correct value. For the correct determination of amount of water to be added in the concrete mix, to maintain the water cement ratio constant, the amount of moisture content in both coarse and fine aggregates shall be taken into consideration, be as frequently as possible, the frequency for a given job being determined by the Engineer according to weather conditions.

4.12.3 Determination of moisture content in the aggregates

Determination of moisture content in the aggregates shall be according to I.S. 2386 (Part-III)-1963. Where tests are not conducted, the amount of surface water may be estimated from the following table :

	LAYING, INSTALLATION, TESTING AND COMMISSIONING OF 8" DIA. STEEL GAS PIPELINE CONNECTIVITY IN PATAN GA	
TENDER DOCUMENT NO REPL/SGL/STPL/009/22		Date: -28/11/2022

Aggregates	Surface water carried by Aggregates	
	% by weight	Lit / m ³
Very wet sand	7.5	120
Moderately wet sand	5.0	80
Moist sand	2.5	40
Moist gravel & stone chips**	1.25 - 2.5	20-40

** - Coarser the aggregate, less the water it will carry.

4.12.4 Admixtures

Any solid admixture, to be added, shall be measured by weight, but liquid or semi-liquid admixture may be measured by weight or volume.

4.12.5 Accuracy of batching

The accuracy of batching shall be within the following tolerance:

Cement within plus or minus 2% by weight.

Aggregate within plus or minus 5% by weight.

Water within plus or minus 0.5% by weight.



4.13 Mixing & Transportation of concrete

4.13.1 Mixing of Concrete

4.13.1.1 Machine mixing

Concrete shall always be mixed in mechanical mixer. Water shall not, normally, be charged into the drum of the mixer until all other ingredients are already in the drum and mixed for at least one minute. Mixing shall be continued until there is uniform distribution of materials and the mass is uniform in colour and consistency. The mixing time from the time of adding water shall be in accordance with IS: 1791-1985 but in no case less than 2 minutes or at least 40 revolutions.

4.13.1.2 Hand mixing

	LAYING, INSTALLATION, TESTING AND COMMISSIONING OF 8” DIA. STEEL GAS PIPELINE CONNECTIVITY IN PATAN GA	
TENDER DOCUMENT NO REPL/SGL/STPL/009/22		Date: -28/11/2022

When hand mixing is permitted by the Engineer it shall be carried out on a water tight platform and care shall be taken to ensure that mixing is continued until the mass is uniform in colour and consistency. In case of hand mixing 10% extra cement shall be added to each batch at no extra cost to the Owner.

4.13.2 Transportation of concrete

4.13.2.1 Concrete shall be transported from the place of mixing to the place of placing concrete as rapidly as practicable by such means which will prevent the segregation or loss of any of the ingredients and maintain the required workability. No water shall be mixed with the concrete after it has left the mixer.

4.13.2.2 Where concrete is transported over long distances, the Contractor shall provide suitable means by which different grades of concrete are readily identifiable at the place of final deposit.



4.13.3 Actions before placement of concrete

4.13.3.1 Programme of works

At the beginning of every fortnight, the contractor shall give his detailed concreting programme for that fortnight to the Engineer. Such programmes, shall specify all information such as the locations where concrete is to be poured, type/grade of concrete, volume of concrete to be poured, number and Type of vibrators proposed to be used as well as proposed to keep as standby, number of skilled technicians and supervisors proposed to be engaged, the proposed time and period of pouring etc.

4.13.3.2 Checking & approval

Before placement of concrete, the contractor shall get all the form works, reinforcements, inserts, conduits, openings, surface preparation etc., checked and approved by the Engineer. To facilitate such checking, the contractor shall complete all his works according to the drawings and specifications well in advance before placement of concrete at least 36 hours for all major/important/complicated works and 24 hours for all minor/ordinary/simple works. The checks are purely in the interest of the work and to draw the contractor's attention to his contractual obligations to execute the works according to the

	LAYING, INSTALLATION, TESTING AND COMMISSIONING OF 8” DIA. STEEL GAS PIPELINE CONNECTIVITY IN PATAN GA	
TENDER DOCUMENT NO REPL/SGL/STPL/009/22		Date: -28/11/2022

drawings/specification and do not relieve the contractor from his responsibility in getting the end results for the quality & strength of concrete and for maintaining the shape, level & dimensions of the finished concrete, as well as the inserts, openings, other features within the tolerance limits.

4.14 Preparatory Works/Surface Preparation

4.14.1 For concrete directly on earth foundation



4.14.1.1 Earth foundation on which direct placement of concrete is specified, shall be rammed and consolidated as directed by the Engineer such that it does not crumble and get mixed with concrete during or after placement. If the foundation is quite wet, the same shall be kept dry and then sufficiently consolidated, if necessary, a thin top layer of the wet soil shall be removed and replaced by sand or other suitable materials as directed by the Engineer without any extra cost to the Owner. Care shall also be taken that earth from the sides also does not get mixed with the concrete, during or after placement, before it has sufficiently set and hardened.

4.14.1.2 The earth foundation, over which concrete is to be placed direct, shall not be kept abandoned at the specified level and concrete shall be placed immediately following the final preparation of the formation otherwise suitable measures shall be taken, as directed by the Engineer without any extra cost to the Owner.

4.14.2 For construction joints

All such joints shall have continuous square bond grooves to produce a substantial and water-tight key. Where the placement of concrete has to be resumed on a surface which has hardened, it shall be roughened, cleaned by wire or bristle brushing, compressed air, water jet etc., and thoroughly wetted. For vertical construction joints a neat cementslurry shall be applied on the surface immediate before the placement of concrete. For horizontal joints the surface shall be covered with a layer of freshly mixed mortar about 10 to 15 mm thick composed of cement and sand in the same proportion as the cement and sand in the concrete mix and applied immediately before placing of the concrete.

On this surface (i.e. on the surface of joints) a layer of concrete not exceeding 150 mm in thickness shall first be placed and shall be well rammed against old work, particular attention being paid to corners and

	LAYING, INSTALLATION, TESTING AND COMMISSIONING OF 8” DIA. STEEL GAS PIPELINE CONNECTIVITY IN PATAN GA	
TENDER DOCUMENT NO REPL/SGL/STPL/009/22		Date: -28/11/2022

close spots. To ensure water tightness, care shall be taken to punn concrete properly against the old surface.

4.14.3 (a) On vertical surfaces of masonry

When the concrete is placed on the vertical surface of masonry (as in the case of thin concrete fins projected from the vertical masonry surface), a groove of dimension as directed by the Engineer shall be cut in the masonry to ensure a proper bond and the surface shall be cleaned thoroughly. Before the placement of concrete, the surface shall be kept moist by spraying water at least for the period of 2 hours and a thick coat of cement slurry shall be applied immediately before the placement of concrete.

b) Over walls



Building paper over average 12mm thick cement sand bearing plaster of 1:4 mix with neat cement finish shall be provided at the bearings of slabs over walls as directed by the Engineer.

4.14.4 Inside the formwork (cleaning, surface preparation etc.,)

The interior of the form works, where the concrete is to be placed, shall be thoroughly washed by high pressure water jet or air jet to completely clean the entire volume from all sort of dirt, grease/oil, foreign and deleterious materials etc. The reinforcement shall be completely clean and free from all sorts of dirt, grease/oil, rust, foreign/deleterious materials etc., Before placement of concrete, the form works coming in contact with concrete, shall be coated with form oil or raw linseed oil material or provided with any approved material to prevent adhesion of concrete to the form work, but utmost care shall be taken so that such oily material do not come in contact with the reinforcement.



4.15 Placing and Compaction of Concrete

4.15.1 The concrete shall be placed and compacted before setting commences & should not be subsequently disturbed. No water shall be mixed with the concrete after it has left the mixer. Method of placing should be such as to preclude segregation. Approved mechanical vibrator shall be used



	LAYING, INSTALLATION, TESTING AND COMMISSIONING OF 8” DIA. STEEL GAS PIPELINE CONNECTIVITY IN PATAN GA	
TENDER DOCUMENT NO REPL/SGL/STPL/009/22		Date: -28/11/2022

for compacting concrete, and concrete shall not be over vibrated or under vibrated. No concrete shall be placed until the place of deposit has been thoroughly inspected and approved by the Engineer. all inserts and embedments properly secured in position and checked and forms properly oiled. No concrete shall be placed in the absence of the Engineer.

- 4.15.2 Concrete shall be placed on clean bed having the designed level. The bed shall be cleaned of all debris and other objectionable materials. Seepage water, if any, shall be controlled or diverted.
- 4.15.3 Concreting shall not be carried on during rains unless all precautions have been taken by the Contractor and necessary permission has been given by the Engineer. Suitable measures shall be taken to control the temperature of concrete.
- 4.15.4 Where plums are permitted in massive concrete, they shall be washed and carefully placed. No stone shall be closer than 30 cm to an exposed face, nor nearer than 15 cm to an adjacent stone.
- 4.15.5 Concrete shall not be dropped from a height of more than 2m except through a chute, the design and type of which shall be subject to approval of the Engineer.
- 4.15.6 The concrete shall be placed, spread and compacted by approved mechanical vibrator. Vibrators shall not be used for pushing concrete to adjoining areas.
- 4.15.7 For members involving vertical placing of concrete (eg. columns, walls etc.), each lift shall be deposited in horizontal layer extending the full width between shutterings and of such depth that each layer can be easily and effectively vibrated and incorporated with the layer below by means of compaction.
- 4.15.8 For member involving horizontal placing of concrete (e.g. slabs, beams etc.) the concrete shall be placed along the line of starting point in such quantities as will allow members to be cast to their full depth along the full width between side shuttering and then gradually brought towards the finishing point along its entire front parallel to the starting line. Vibration and surface finish shall follow behind the placement as closely as possible.

	LAYING, INSTALLATION, TESTING AND COMMISSIONING OF 8” DIA. STEEL GAS PIPELINE CONNECTIVITY IN PATAN GA	
TENDER DOCUMENT NO REPL/SGL/STPL/009/22		Date: -28/11/2022

- 4.15.9 Utmost care shall be taken to avoid the displacement of reinforcements/embedded parts or movement of formwork or damage to faces of the form work or transmission of any harmful vibration/shocks to the concrete which has not yet hardened sufficiently.
- 4.15.10 All members shall be concreted at such a rate that no cold joint is formed and fresh concrete is placed always against green concrete which is still plastic and workable.
- 4.15.11 Should any unforeseen occurrence results in a stoppage of concreting for one hour or such other time as might allow the concrete, already placed, to begin to set before the next batches can be placed, the Contractor shall make at his own cost, suitable tongue, and groove construction joint, as approved by the Engineer. Any additional reinforcement required as directed by the Engineer shall also be provided by the Contractor at his own cost. Before placement of new batches of concrete over that construction joint, the surface preparation according to this specification stipulated earlier, shall be done by the Contractor at his own cost.
- 4.15.12 The concrete shall be worked well up against whatever surface it adjoins and compacted to such a degree that it reaches its maximum density as a homogeneous mass, free from air and water holes and penetrates to all corners of moulds and shuttering and completely surrounds the reinforcement. All measures shall be taken to make the shape, size, and location of the finished concrete including its embedments, holes, openings etc., well within the accepted tolerance limit.
- 4.16 Construction Joint & Cold Joints**
- 4.16.1 Construction joints**
- 4.16.1.1 Normally, the construction joints including crank inducing joints shall be constructed as per locations and details indicated on the drawings.
- 4.16.1.2 Where the location of the joint is not specified in the drawings, it shall be in accordance with the following guide lines:
- (a) In Columns**
- (i) In case of Projection from basement slab, 300 mm from**

	LAYING, INSTALLATION, TESTING AND COMMISSIONING OF 8" DIA. STEEL GAS PIPELINE CONNECTIVITY IN PATAN GA	
TENDER DOCUMENT NO REPL/SGL/STPL/009/22		Date: -28/11/2022

the top of base slab or 75 mm from the top of the haunches whichever is higher.

- (ii) In framing of beam at different elevation, 75 mm below the lowest soffit of the beam and in case of projection from beams and slabs 75 mm from the top surface of the beam/slab or at the top surface of beam/Slab whichever facilitates formwork.
- (iii) For columns under flat slabs 75 mm below the lowest soffit of the slab.

(b) In walls (horizontal construction joints)

(i)	Walls projecting from base slab	:	300 mm from top of base slab
(ii)	Walls supporting the suspended slab	:	75 mm from the lowest soffit of the slab

Note :

In the case of water retaining structures and structures under the influence of ground water, approved water bars of suitable size shall be provided to make the joint completely water-tight.



(c) In beams

Beams shall be cast, as a rule, without a joint. But if provision of a joint is unavoidable, the joint for simply supported beam shall be vertical and at the middle of the span ; in continuous beam, the same shall be at the point of minimum shearforce.

(d) In suspended slabs

- (i) In slab of small span, there shall be no construction joints.
- (ii) In slabs of large span and continuous slabs, construction joint, if allowed by the Engineer shall be vertical at the middle of span and at the right angles to the principal reinforcement.

(e) In walls (Vertical construction joint)

	LAYING, INSTALLATION, TESTING AND COMMISSIONING OF 8" DIA. STEEL GAS PIPELINE CONNECTIVITY IN PATAN GA	
TENDER DOCUMENT NO REPL/SGL/STPL/009/22		Date: -28/11/2022

As a rule, walls shall be cast monolithically without any vertical construction joint, unless specified in the drawing. However, for a long wall, the Engineer may allow vertical construction joint and the same shall be at the place of minimum shear force. In water retaining structures and in structures under the influence of ground water approved water bars of suitable size shall be provided to make the joints completely water tight.

(f) In slabs resting on ground

(i) For Plain concrete

Concreting shall be done in alternate panels not exceeding 10 sq.m in area. The largest panel dimension shall be 5 m.

(ii) For nominally reinforced slab

The area of pour shall not exceed 40 sq.m and the maximum panel dimension shall not exceed 8m.

(i) For the basement slabs which act as structural member



There shall be no construction joint.

(g) In ribbed beam

The beams shall be cast monolithically with the slab in one continuous operation.

4.16.1.3 In all construction joints the reinforcements shall pass through as per drawings and the same shall not be disturbed in any way.

4.16.1.4 The vertical construction joints shall be provided by insertion of board keeping provision for passage of reinforcement/fixtures / embedments. All construction joints shall be made to form a tongue and groove joint.

	LAYING, INSTALLATION, TESTING AND COMMISSIONING OF 8” DIA. STEEL GAS PIPELINE CONNECTIVITY IN PATAN GA	
TENDER DOCUMENT NO REPL/SGL/STPL/009/22		Date: -28/11/2022

4.16.2 Cold joint

An advancing face of a concrete pour, which could not be covered before expiry of initial setting time for unexpected reasons, is called a cold joint. The Contractor shall remain always vigilant to avoid cold joints. If however, a cold joint is formed due to unavoidable reasons, the following procedures shall be adopted for treating it :



- (a) If the concrete is so green that it can be removed manually and if vibrators can penetrate the surface without much effort, fresh concrete can be placed directly over the old surface and the fresh concrete along with the old concrete shall be vibrated systematically and thoroughly.
- (b) In case the concrete has hardened a bit more than (a), but can still be easily removed by a light hand pick, the surface shall be raked thoroughly and the loose concrete removed completely without disturbing the rest of the concrete in depth. Then a rich mortar layer of 12 mm thickness, shall be placed on the cold joint and then the fresh concrete shall be placed on the mortar layer and vibrated thoroughly, penetrating deep in to the layer of concrete.
- (c) In case the concrete at the joint has become so stiff that it cannot be remoulded and mortar or slurry does not rise in spite of extensive vibration, a tongue and groove joint shall be made by removing some of the older concrete and the joint shall be left to harden at least for 12-24 hours. It will then be treated as regular construction joint and the surface preparation of the same, before placement of concrete, shall be as described in the appropriate clauses of these specifications.

4.17 Requirements for Concreting in Special Cases

4.17.1 Concreting in deep lifts

Placing of concrete in lifts exceeding 2 M in columns and walls is in the category of deep lifts.

- 4.17.1.1 Before commencement of work, the contractor shall submit for the approval of the Engineer, the details of the methods he proposes to

	LAYING, INSTALLATION, TESTING AND COMMISSIONING OF 8” DIA. STEEL GAS PIPELINE CONNECTIVITY IN PATAN GA	
TENDER DOCUMENT NO REPL/SGL/STPL/009/22		Date: -28/11/2022

adopt for concreting.

4.17.1.2 The placement of concrete shall preferably be by tremie, chute or any other approved method.

4.17.1.3 In structures of heavy/complicated reinforcement or in complicated form works, the contractor shall provide sufficient number of windows in the form works as directed by the Engineer to check the placement and compaction of concrete in different stages. Such windows shall be closed as soon as the concreting reaches the bottom level of the same.

4.17.2 Concreting under water

When it is necessary to deposit concrete under water, the special requirements, over and above those of this specification shall be in accordance with Clause 13.2 of IS: 456-1978.

4.17.3 Cold weather concreting

When conditions are such that the ambient temperature may be expected to be 4.5 C degree or below during the placing and curing period, the work shall conform to IS: 7861 (Part-II)-1981.



4.17.4 Hot weather concreting

When concreting in very hot weather the Contractor shall take all precautions as stipulated in IS: 7861 (Part-I)-1975 and stagger the work to cooler parts of the day to ensure that the temperature of wet concrete used, specially in massive structure, does not exceed 38 degree 'C'.

Positive temperature control by methods like pre-cooling, post cooling or cooling of concrete by circulating cold water through small embedded pipe lines inside concrete, if required, shall be specified and shall be undertaken.

4.18 Finishes to Exposed Surfaces of Concrete

The Contractor is to include in his quoted rate for concrete, the provision of normal finishes in both formed & unformed surfaces as and where required by the Engineer without any extra cost to the owner. Some common finishes are indicated below:

	LAYING, INSTALLATION, TESTING AND COMMISSIONING OF 8” DIA. STEEL GAS PIPELINE CONNECTIVITY IN PATAN GA	
TENDER DOCUMENT NO REPL/SGL/STPL/009/22		Date: -28/11/2022

4.18.1 Surface which do not require plastering

Surface in contact with casings shall be brought to a fair and even surface by working the concrete smooth against casings with a steel trowel while it is being deposited and also by working over the surface with a trowel immediately after the removal of the casings or centerings, removing any irregularities and stopping air holes, etc. Use of mortar plaster is not permissible for correcting levels, removing unevenness etc. However, if, in the opinion of the Engineer, such plastering is unavoidable then the thickness of plaster shall in no case exceeds 5 mm and the plastering shall be in cement and sand mortar.(1:3).

4.18.2 Exposed surfaces which need plastering

Surfaces of beams/columns flushing with the block work or other structures where intended to plaster, shall be hacked adequately as soon as the shuttering is stripped off so that proper bond with the plaster can develop.

4.18.3 Surface for non-integral finish

Where a non-integral finish such as floor finish is specified or required, the surface of the concrete shall be struck off at the specified levels and finished rough.



4.18.4 For monolithic finish

Where no more finishing course is to be applied as in the case of basement floor, industrial flooring or the screed concrete flooring etc, the concrete shall be completed and struck off at the specified levels and sloped with a screed, board and then floated with a wooden float. Steel troweling is then started after the concrete has hardened enough to prevent the excess of fines and water to rise to the surface but not hard enough to prevent proper finishing. Troweling shall be such that the surface is flat, smooth and neatly finished.

4.19 Curing of Concrete

4.19.1 General

The purpose of curing is to prevent loss of moisture from the concrete itself so that the cement inside the concrete is sufficiently hydrated

	LAYING, INSTALLATION, TESTING AND COMMISSIONING OF 8” DIA. STEEL GAS PIPELINE CONNECTIVITY IN PATAN GA	
TENDER DOCUMENT NO REPL/SGL/STPL/009/22		Date: -28/11/2022

which of course is slow and prolonged process. As soon as the concrete has hardened sufficiently the curing shall be started. To cure the concrete properly and sufficiently is also the sole responsibility of the contractor.

4.19.2 Different methods of curing

Any one of the following methods may be used for curing as approved by the Engineer.

- (a) Curing by direct water.
- (b) Curing by covering the concrete with absorbent material and kept damp.

4.19.3 Curing by direct water

This is done either by ponding or spraying water.

(a) Ponding

Ponding is widely used for curing slab and pavements. Earth bunds are formed over the slabs and water is pumped or poured into them and the same is replenished at interval to make up for the loss of evaporation. As this type of curing is one of the best methods, 10 days of curing after final setting is sufficient.



(b) By spraying water

Curing is done by spraying water by suitable means at approved time intervals. While spraying, it shall be ensured that the complete area is covered. In order to avoid cracking, cold water shall not be applied to massive members immediately after striking the form work, while the concrete is still warm. Alternate wetting and over drying shall be avoided.

Curing by spraying water shall be continued at least for 18 days after final setting.

4.19.4 Curing of concrete with absorbent material kept damp

The entire concrete surface is covered either with hessian, burlap,

	LAYING, INSTALLATION, TESTING AND COMMISSIONING OF 8" DIA. STEEL GAS PIPELINE CONNECTIVITY IN PATAN GA	
TENDER DOCUMENT NO REPL/SGL/STPL/009/22		Date: -28/11/2022

sawdust, sand, canvas or similar material and kept wet continuously for at least 12 days after final setting.

4.20 Testing of Concrete

4.20.1 General

The Contractor shall carry out, entirely at his own cost, all sampling and testing in accordance with the relevant I.S. standards and as supplemented herein. The Contractor shall get all tests done in approved Laboratory and submit to the Engineer, the test result in triplicate within 3 days after completion of the test.

4.20.2 Consistency test (tests of fresh concrete)

4.20.2.1 At the place of deposition/pouring of the concrete, to control the consistency, slump tests and/or compacting factor tests shall be carried out by the Contractor in accordance with I.S. 1199-1959 as directed by the Engineer.



4.20.2.2 The results of the slump tests/compacting factor tests shall be recorded in a register for reference duly signed by both the Contractor and the Engineer. That register shall be considered as the property of the Owner and shall be kept by the Contractor at site in safe custody.

4.20.2.3 The results of the slump tests/compacting factor tests shall tally, within accepted variation of plus or minus 12% with the results in the respective design mix, in case of mix design concrete and with the values indicated in the table under clause 6.1 of IS: 456 in case of nominal mix concrete.

4.20.2.4 For any particular batch of concrete, if the results do not conform to the requirements as specified in 4.20.2.3 or do not conform to any requirement of this specification, the Engineer has the right to reject that batch and the Contractor shall remove the same immediately from the site, at no cost to the Owner.

4.20.3 Strength test of concrete

4.20.3.1 While placing concrete, the Contractor shall make 6 nos. of 15 cm test cubes from particular batches of concrete as desired by the Engineer.

	LAYING, INSTALLATION, TESTING AND COMMISSIONING OF 8" DIA. STEEL GAS PIPELINE CONNECTIVITY IN PATAN GA	
TENDER DOCUMENT NO REPL/SGL/STPL/009/22		Date: -28/11/2022

The frequency of taking test cubes shall be either according to clause 14.2 of IS: 456-1978 or as directed by the Engineer.

4.20.3.2 The cubes shall be prepared, cured and tested according to IS: 516-1959. Out of 6 nos. of test cubes 3 shall be tested for compressive strength at 7 days after casting and the remaining 3 at 28 days after casting.

4.20.3.3 A register shall be maintained at site by the Contractor with the following details entered and signed by both the Contractor and the Engineer. That register shall be considered as the property of the Owner.



- (a) Reference to the specific structural member
- (b) Mark on cubes
- (c) The grade of concrete
- (d) The mix of concrete
- (e) Date and time of casting
- (f) Crushing strength at 7 days
- (g) Crushing strength at 28 days
- (h) Any other information directed by the Engineer.

4.20.4 Acceptance criteria for test cubes

The acceptance criteria of concrete on strength requirement shall be in accordance with the stipulations under clause 15 of IS: 456-1978.

4.20.5 Non-destructive tests on hardened concrete

4.20.5.1 If there is doubt about the strength or quality of a particular work or the test results do not comply with the acceptance criteria as stipulated under clause 15 of IS: 456-1978, non-destructive tests on hardened concrete like core test and/or load tests or other type of non destructive tests like ultrasonic impulse test etc. shall be carried out, as may be directed by the Engineer, by the Contractor at entirely his own cost.

	LAYING, INSTALLATION, TESTING AND COMMISSIONING OF 8” DIA. STEEL GAS PIPELINE CONNECTIVITY IN PATAN GA	
TENDER DOCUMENT NO REPL/SGL/STPL/009/22		Date: -28/11/2022

4.20.5.2 The core tests and load tests shall comply with the requirements of clause 16.3 and 16.5 of IS: 456-1978 respectively. In case of other types of special tests like ultrasonic impulse test etc., the stipulation of clause 16.6 of IS: 456-1978 shall be applicable.



4.20.6 Concrete below specified strength

In case of failure of test cubes to meet the specified requirements the Engineer may take one of the following actions:-

- 1) Instruct the Contractor to carryout additional test and/or works to ensure the soundness of the structure at Contractor's expense.
- 2) Reject the work and instruct that section of the works to which the failed cubes relate shall be cut out and replaced at Contractor's expense and the resultant structures affected due to such rejection shall be made good at contractor's expense.
- 3) Modification/remedial measures if approved by the engineer to be carried out at contractor's expense.
- 4) Accept the work with reduction in the rate in appropriate item subject to the provisions of clause 15 of IS 456-1978 provided it is technically acceptable. The reduction in the rate shall be as given below :-
 - i) When test strength of the sample is above 90% of the characteristic strength, payment shall be made 10% less than the contract rate.
 - ii) When test strength of the sample is between 80-90% of the characteristic strength, payment shall be made 25% below than the contract rate.

4.20.7 Concrete failed in non-destruction tests

In case the test results of the core tests or load tests in a particular work do not comply with the requirements of respective clause (16.3 for core test and 16.5 for load tests) of IS: 456-1978 the whole or part of the work concerned shall be dismantled and replaced by the Contractor as may be directed by the Engineer at no extra cost to the Owner and to the satisfaction of the Engineer. No payment for the dismantled

	LAYING, INSTALLATION, TESTING AND COMMISSIONING OF 8" DIA. STEEL GAS PIPELINE CONNECTIVITY IN PATAN GA	
TENDER DOCUMENT NO REPL/SGL/STPL/009/22		Date: -28/11/2022

concrete including relevant form work, reinforcement, embedded fixtures etc. shall be made. In the course of dismantling if any damage occurs to the adjacent structure or embedded item, the same shall be made good, free of charge by the Contractor, to the satisfaction of the Engineer.

4.21 Steel Reinforcement

4.21.1 Material

Material shall be as specified in the respective schedule of Items. The specifications of materials shall be as per Part-I.

4.21.2 Storage

Steel reinforcement shall be stored in such a manner that they are not in direct contact with ground. Bars of different classifications and sizes shall be stored separately. In cases of long storage or in coastal areas, reinforcement shall be stacked above ground level by at least 15 cm, and a coat of cement wash shall be given to prevent scaling and rusting at no extra cost of the owner.



4.21.3 Bending and placing

Bending and placing of bars shall be in conformity with IS: 2502-1963 "Code of Practice for Bending and Fixing of Bars for Concrete Reinforcement" and IS: 456 -1978 "Code of Practice for Plain and Reinforced Concrete".

4.21.4 Welding of Reinforcement

Welding of mild steel reinforcement bars conforming to IS:432 (Part-I)-1982 shall be done in accordance with IS: 2751 -1979 "Code of Practice for Welding of Mild Steel Bars used for Reinforced Concrete construction" with additional precaution that for lap welded joints the throat thickness of weld beads shall be at least 3 mm or 0.6 times the nominal size of weld (which is the radius of bar) whichever is more.

Welding of cold worked high strength deformed bars conforming to IS: 1786-1985 shall be done using electric arc welding process using low hydrogen electrodes (Ferro Weld- I or Ferro Weld-II or equivalent). Oxy-acetylene welding shall not be used.

	LAYING, INSTALLATION, TESTING AND COMMISSIONING OF 8" DIA. STEEL GAS PIPELINE CONNECTIVITY IN PATAN GA	
TENDER DOCUMENT NO REPL/SGL/STPL/009/22		Date: -28/11/2022

Butt welding of bars upto 32 mm diameter for vertical splices shall be done either by single bevel groove weld or double bevel groove weld, with bevel angle 45 degree. Butt welding of bars upto 32 mmdiameter for horizontal splices shall be done either by single Vee-groove weld or double Vee-groove weld with chamfered angle of 45 degree to 60 degree. The diameter of welded joint shall be 1.2 times the diameter of bar. Edge preparation for butt welding shall be done by shearing, machining and grinding. Oxy-acetylene flame shall not be used for cutting. Chamfered faces shall be smooth finished by hand file if required.



Lap welding of bars upto 20 mm diameter shall have a minimum bead length of 12 times the diameter of bar or 200 mm whichever is more arranged on one or both sides. The throat thickness of weld beads shall be 5 mm or 0.75 times the nominal size of weld (which is the radius of bar) whichever is more. In case of unsymmetrical lap weld with weld bead on one side only, the maximum length of each weld bead shall be 6 times the diameter of bar or 100 mm (whichever is more), separated by an equal length in between weld beads. Splice bars used in symmetrical weld joint shall have same diameter as the parent bars. Lap joint with single splice bars shall have weld beads on both sides.

Lap welding of bars above 20 mm shall be done using splice plate or splice angle. Thickness of splice plate shall not be less than 0,65 times the diameter of bar and width shall not be less than twice the diameter of bar. The size of splice angle shall be such that its area of cross section is at least 1.62 times the area of bar being spliced.

More than one third of the bars shall not be welded at any one section and welded joints shall be staggered at a distance of 50 times the diameter of bars. Welding shall not be done at bends or curved parts of bars and it shall be located at least at a distance of 50 times the diameter of bar from bends.

Tests

Test pieces of welded bars shall be selected and tested in accordance with the provisions of IS: 2751-1979. The number of tests will be as laid down in IS: 2751-1979 or such larger number as the Engineer may decide having regard to the circumstances.

	LAYING, INSTALLATION, TESTING AND COMMISSIONING OF 8" DIA. STEEL GAS PIPELINE CONNECTIVITY IN PATAN GA	
TENDER DOCUMENT NO REPL/SGL/STPL/009/22		Date: -28/11/2022

4.21.5 Cleaning

All steel for reinforcement shall be free from loose scales, rust coatings, oil, grease, paint or other harmful matters immediately before placing the concrete. To ensure this, reinforcements with rust coatings shall be cleaned thoroughly before bending/placement of the same.

4.21.6 Placing in position

All reinforcements shall be accurately fixed and maintained in positions as shown on the drawings and by adequate means like mild steel chairs and/or concrete spacer blocks as required. Bars intended to be in contact at crossing points, shall be securely tied together at all such points by 20G annealed soft steel wire or by tack welding in case of bars larger than 25 mm dia, as may be directed by the Engineer. Binders shall tightly embrace the bars with which they are intended to be in contact and shall be securely held. The vertical distance between successive layers of bars shall be maintained by provision of mild steel spacer bars. They should be spaced such that the main bars do not sag perceptibly between adjacent spacers.



4.21.7 Clear cover

Clear cover shall be as specified in the drawings. If nothing is specified in the drawing the clear cover shall be in accordance with the relevant clause of IS: 456-1978.

4.21.8 Light structural work and embedded metallic parts, conduits

4.21.8.1 Fabrication of metallic parts & light structural works

Fabrication of all structural steel work shall be done in accordance with IS: 800 -1984 "Code of Practice for use of Structural Steel in General Building Construction". Workmanship shall match to the best practice in modern structural shops. Greatest accuracy shall be observed in the manufacture of every part and all identical parts shall be strictly interchangeable. Steel work shall be shop fitted and shop assembled as far as practicable to minimise site work and to meet transport restrictions. All materials shall be straight and if necessary before being worked shall be straightened or flattened by pressure and shall be free from twists. Shearing or flame cutting may be used and the resulting edges shall be clean and straight. Flame cut edges shall be planed/cleaned by chipping or grinding. Sheared members shall be free from distortion

	LAYING, INSTALLATION, TESTING AND COMMISSIONING OF 8” DIA. STEEL GAS PIPELINE CONNECTIVITY IN PATAN GA	
TENDER DOCUMENT NO REPL/SGL/STPL/009/22		Date: -28/11/2022

at sheared edges. Welding and welded work shall conform to IS: 816 - 1969 "Code of Practice for use of metal arc welding for General Construction in Mild Steel". Mild steel electrodes conforming to IS: 814-1991 "Specification for covered electrodes for metal arc welding of mild steel shall be used.

4.21.8.2 Transportation and Storages

All pieces shall be properly identified and bundled for transportation to work site. Care shall be exercised in the delivery, handling and storage of material to ensure that material is not damaged in any manner. Materials shall be kept free of dirt, grease and foreign matter and shall be stored properly on skids or any other suitable supports to avoid contact with ground, damage due to twisting, bending etc.



4.21.8.3 Erection of light structural work

Erection of light structural work shall be carried out in accordance with the provisions of IS: 800-1984. No component which is bend or twisted shall be put in place until the defects are corrected. Components seriously damaged during handling shall be replaced. No riveting, permanent bolting or welding shall be done until proper alignment has been completed. Whenever field welding is to be done it shall be in accordance with the requirements of shop fabrication. Shop paints shall be removed before field welding for a distance of at least 50 mm on either side of the joints.

4.21.8.4.1 Erection of embedded metallic parts, inserts, conduits

Bolts and inserts shall be securely fixed in position as shown in the drawings, before commencement of concreting. Bolts shall be checked for accuracy in alignment on both the axes. Limits of tolerance in alignment and level shall be as shown in the drawing or described elsewhere in these specifications.

Where bolts are housed in sleeves, special care shall be taken after concreting is over and has partly set to ensure that the bolts move within the sleeves. The annular space of the sleeve shall be plugged with suitable stoppers to prevent the ingress of water, grout, dust, rubbish or other foreign material into it, both during and after concreting. Opened conduits shall be plugged similarly. Where channels, Unshapely profiles or other similar inserts are required to be

	LAYING, INSTALLATION, TESTING AND COMMISSIONING OF 8" DIA. STEEL GAS PIPELINE CONNECTIVITY IN PATAN GA	
TENDER DOCUMENT NO REPL/SGL/STPL/009/22		Date: -28/11/2022

placed in concrete, special care shall be taken to keep the grooves of such profiles free from the ingress of concrete, slurry etc., by suitable packing material, if necessary.

All threads for bolts and inserts shall be greased at intervals and kept covered to prevent damage.

- 4.21.8.4.2** Necessary templates, jigs, fixtures, supports shall be used as may be specified or required or directed by the Engineer free of cost to the Owner.

Exposed surfaces of embedded materials shall be painted with one coat of anticorrosive paint or bituminous paint, as desired, without any extra cost to the Owner. If welding is to be done subsequently on the exposed surfaces of the embedded parts, the painting for a length of 50mm beyond each side of the weld line shall be cleaned off.

4.22 Shuttering



4.22.1 General

All shuttering, formwork, supports and staging shall be designed by the Contractor and be subject to approval by the Engineer. The Contractor shall submit drawings and calculations to the Engineer for scrutiny when called upon to do so. The shuttering shall be designed for a live load of 400 Kg/m² in addition to the weight of the green concrete, or such other load as the Engineer may specify. The Contractor shall be responsible for the correctness and strength of the formwork including its supports and centering and approval by the Engineer will not relieve him of his responsibilities.

4.22.2 Material

The staging and supports may be of round or sawn timber or tubular or other shapes in steel. Round timber shall preferably extend over the full height in one piece. These shall be securely jointed or otherwise fastened and spaced at suitable intervals as the design may warrant and shall be suitably braced at regular intervals horizontally and diagonally.

The form work shall be of steel plate on steel frame, wooden boards with steel sheet lining, or plywood or seasoned timber board. Where

	LAYING, INSTALLATION, TESTING AND COMMISSIONING OF 8” DIA. STEEL GAS PIPELINE CONNECTIVITY IN PATAN GA	
TENDER DOCUMENT NO REPL/SGL/STPL/009/22		Date: -28/11/2022

ornamental and curved surfaces are required the material shall be very good seasoned timber or plywood which can be shaped correctly.

4.22.3 Fixing

The shuttering shall conform to the shapes, lines, levels and dimensions shown in the drawing. It shall be fixed in perfect alignment and securely braced so as to be able to withstand, without appreciable displacement, deflection or movement of any kind, the weight of all construction, movement of persons and plant. It shall be so constructed as to remain rigid during the placing and compacting of concrete without shifting or yielding and shall be sufficiently water tight to prevent loss of slurry from the concrete.

All props shall be supported on sole plates and double wedges. At the time of removing props these wedges shall be gently eased and not knocked out. The form work shall be so designed that the sides are independent of the soffits and the side forms can be removed easily without any damage or shock to the concrete.

4.22.4 Wrought shuttering

Wrought shuttering shall be such as to produce a first class fair face on the concrete free from board marks or any other disfigurements. This shall be used for exposed surfaces where specified or directed by the Engineer. It may be made of heavy quality plywood or steel sheets having smooth, plain surface.



The joints in shuttering shall be arranged in a regular pattern approved by the Engineer. Wrought shuttering shall be aligned within a tolerance of 3 mm.

4.22.5 Rough shuttering

Rough shuttering shall be used for all surface of concrete walls, footings etc., which are not exposed in the finished work or which are to receive plaster and as directed by the Engineer. It may be made of timber, ordinary plywood or steel sheets.

4.22.6 Special provision

4.22.6.1 Wherever concreting of narrow member is required to be carried out

	LAYING, INSTALLATION, TESTING AND COMMISSIONING OF 8” DIA. STEEL GAS PIPELINE CONNECTIVITY IN PATAN GA	
TENDER DOCUMENT NO REPL/SGL/STPL/009/22		Date: -28/11/2022

within shutters of considerable depth, temporary openings in the sides of the shutters shall, if so directed by the Engineer, be provided to facilitate cleaning, pouring and consolidation of concrete.

- 4.22.6.2 In liquid retaining structures and structures below ground water level, through bolts for the purpose of securing and aligning the form work shall not be used.
- 4.22.6.3 Forms shall be given an upward camber, if so desired by the Engineer, to ensure that long beams do not have any sag. The camber may be 1 in 250 or as the Engineer may direct.
- 4.22.6.4 The joints in form work shall be sealed by adhesive tapes or by other means, to prevent any leakage of slurry or mortar if so directed by the engineer.

4.22.7 Preparation for concreting

Before any concreting is commenced the shuttering shall be carefully examined for dimensional accuracy and safety of construction. The space to be occupied by concrete shall be thoroughly cleaned out to remove rubbish, debris, shavings and saw dust. The surface in contact with concrete shall be coated with an approved substance such as mould oil or other non-staining mineral oil to prevent adhesion. Where necessary the surface shall be wetted to prevent absorption of moisture from concrete. Care shall be taken to avoid the reinforcements coming in contact with shutter oil.

4.22.8 Removing

- 4.22.8.1 Removal of forms shall never be started until the concrete has thoroughly set and aged to attain sufficient strength to carry twice its own weight plus the live load that is likely to come over it during construction
- 4.22.8.2 Removal of forms shall not entail chipping or disfiguring of the concrete surface. Shuttering shall be removed without shock or vibration and shall be eased off carefully in order to allow the structure to take up its load gradually.
- 4.22.8.3 Under normal circumstances (generally where temperatures are above 21 degree 'C'), and where ordinary portland cement is used shuttering may be struck after the expiry of the following periods :-



**LAYING, INSTALLATION,
TESTING AND COMMISSIONING
OF 8” DIA. STEEL GAS PIPELINE
CONNECTIVITY IN PATAN GA**



**TENDER DOCUMENT NO
REPL/SGL/STPL/009/22**

Date: -28/11/2022

i)	Walls, columns & vertical faces	24 to 48 hours as may be directed by the Engineer.
ii)	Bottom of slab upto 4.5 m span	7 days
iii)	Bottom of slab above 4.5 m span, bottom of beam and arch, rise upto 6 m span	14 days
iv)	Bottom of beam and arch rise over 6 m span	21 days

These periods may be increased at the discretion of the Engineer. Special care shall be taken while striking the shuttering of cantilevered slabs and beams, portal frames etc.,

4.22.8.4 Before removing the form work, the Contractor must notify the Engineer to enable him to inspect the condition of the finished concrete immediately after the removal of the form works.

4.22.9 Contractor's responsibility



Any damage resulting from faulty preparation, premature or careless removal of shuttering shall be made good by the Contractor at his own expense.

4.22.10 Irrecoverable shuttering

In cases where the shuttering cannot be removed without damaging the structure itself or where removal of shuttering is rendered impossible due to the nature of construction or where the Engineer may so instruct, such shuttering shall be classified as irrecoverable shuttering. However, such abandoning of shuttering will be permitted only in situations where it will not remain exposed or otherwise cause damage of any kind.

4.22.11 Metal Forms

Where permanently left-in-place metal forms or deck are shown in drawings or otherwise ordered to be provided by the Engineer, they shall satisfy the requirements with regard to load carrying capacity. The metal forms shall be obtained from a reputed manufacturer, whose performance guarantee shall be obtained and submitted to the

	LAYING, INSTALLATION, TESTING AND COMMISSIONING OF 8" DIA. STEEL GAS PIPELINE CONNECTIVITY IN PATAN GA	
TENDER DOCUMENT NO REPL/SGL/STPL/009/22		Date: -28/11/2022

Engineer. Designs and drawings giving full details shall be submitted to the Engineer in advance for approval.

4.23 Damp Proof Course Concrete

4.23.1 Thickness

It shall be as specified in the drawings or in the items.

4.23.2 Mix

The grade of mix shall be as specified in the drawing or schedule of quantities. If nothing is specified, the mix shall be 1 part of cement : 1 1/2 part of coarse sand : 3 parts of stone chips. The stone chips shall be 12 mm down graded.

Approved water proofing admixture shall be mixed with cement as per manufacturer's specifications. The water cement ratio shall be as low as possible to increase the impermeability of concrete and in no case more than 0.5.

4.23.3 Preparation of base surface



The base surface shall be well roughened by chipping and brushing with steel brush and shall be cleaned of all dirt, dust, grease, oil and all other foreign & deleterious materials. Then the surface shall be well moistened with water.

4.23.4 Placing and compaction

Just prior to placement of D.P.C. Concrete, a thick coat of cement slurry shall be applied on the base surface. The placement shall be as specified for the concrete in beams. The concrete shall be well compacted to make it dense.

4.23.5 Finishing

When the concrete has set enough but remains still green, the top surface shall be marked in regular pattern by steel trowel so as to have proper bond with the future work.

	LAYING, INSTALLATION, TESTING AND COMMISSIONING OF 8” DIA. STEEL GAS PIPELINE CONNECTIVITY IN PATAN GA	
TENDER DOCUMENT NO REPL/SGL/STPL/009/22		Date: -28/11/2022

4.23.6 Curing

The D.P. course shall be kept continuously moist at least 10 days.

4.24 Grout

4.24.1 Scope

The scope covers the grouting under base plates, grouting between the joints of precast concrete, grouting the pockets/holes/opening etc.

4.24.2 Grouting under base plates

Grouting under base plates of equipments/structures shall be of cement mortar 1:2 for thickness upto 25 mm. For thickness exceeding 25 mm, concrete of grade specified in the drawing or minimum M-20 grade using 10 mm down graded aggregates shall be used. The grout shall be placed in position well rammed until the whole space is completely filled with concrete. No vibrators shall be used. Quick setting cements shall be used in the preparation of mortar or concrete, where so specified.



The grout shall either be "dry" concrete or mortar or "wet expanding" concrete or mortar as the Engineer may direct. A dry grout shall have a slump not exceeding 6 mm. It shall be rammed under the horizontal surface with the aid of suitable tools. A "wet expanding" grout shall have a slump of at least 125 mm but not exceeding 225 mm. To this shall be added an expanding admixture approved by the Engineer and in accordance to the Manufacturer's instructions.

4.24.3 Grouting the pockets/holes in concrete

Depending upon the size of the pockets/holes in the concrete, the mix of the grout shall be either of concrete or of cement sand mortars. Normally the grade of such concrete/mortar shall be M-20 unless specified otherwise. In filling the holes of foundation bolts and expanding admixture of approved type shall be used as per manufacturer's specification.

4.24.4 Workmanship

4.24.4.1 The surface of the concrete over which grouting is to be applied shall be thoroughly prepared to provide a clean rough surface. If necessary,

	LAYING, INSTALLATION, TESTING AND COMMISSIONING OF 8” DIA. STEEL GAS PIPELINE CONNECTIVITY IN PATAN GA	
TENDER DOCUMENT NO REPL/SGL/STPL/009/22		Date: -28/11/2022

chipping shall be carried out on such surface to make it completely rough. Then the surface shall be wetted. Bolt pockets shall be cleaned immediately before the base plate is placed in position. Before grouting the surface shall be thoroughly cleaned with compressed air/water jet.

4.24.4.2 Before placement of grout, the surfaces (except in the case of bolt holes) shall be wetted with cement slurry. In case of bolt holes/pockets water from such pockets shall be thoroughly removed by some suitable means and no cement slurry shall be applied.

4.24.4.3 Hand mixing is not permitted and the grout shall always be machine mixed. If however in some special cases where the quantity of grout is so small that it cannot be machine mixed, hand mixing may be allowed but the same shall be done under the strict supervision of an experienced supervisor of the Contractor.

4.24.4.4 The grout shall be placed within 30 minutes of being mixed. The grout shall be poured and then worked into position by suitable means until the space is completely filled. The Contractor shall take all possible measures during grouting so that the grout fills the space completely and thoroughly. Where the gap is very small or unapproachable for the placement of concrete, the Contractor shall grout by pressure grouting and in that case the mix may be of cement sand mortar of the appropriate grade but in any case the water cement ratio shall be as low as possible. Neither "Dry" grout (having slump 6mm or less) nor expanding wet grout shall be grouted with any type of vibrating machine



4.24.5 Curing

After 10 hours of grouting, the same shall be covered with wet gunny bags and the surface shall be kept continuously moist at least for 10 days.

4.25 Concreting in Water Retaining Structures

General requirements

The basic specifications as regards 'mix' design, placing, compacting, curing etc. shall conform to the requirements as specified herein before

	LAYING, INSTALLATION, TESTING AND COMMISSIONING OF 8” DIA. STEEL GAS PIPELINE CONNECTIVITY IN PATAN GA	
TENDER DOCUMENT NO REPL/SGL/STPL/009/22		Date: -28/11/2022

in this Chapter. Over and above the materials and workmanship shall conform to the stipulations of IS: 3370 (Part-I & II)-1965 to make dense and impervious concrete. As specified herein before all the construction joints shall be provided with approved water bars. The expansion and construction joints, if any, shall be provided with the requirements as specified in the drawing or as directed by the Engineer.

4.26 Application of Live Load

The designated live load shall be allowed on any structure only after 28 days, after proper curing is carried out on the last concrete poured in structure.

4.27 Foam Concrete

This shall be of average 50mm thickness or as specified or as shown on the drawings. This may be laid in in-situ in suitable panels or in precast blocks. The insulating properties shall be such that the thermal conductivity shall not exceed 0.125 Kcl m/m²h/degree C. The weight of the insulating material shall be from 0.5 to 0.75 gm/cm³, strength not less than 5 Kg/sq.cm or (0.5N/sq.mm.). In general, the main ingredients of Foam Concretes are cement, fly ash and foaming agent and the work shall be carried on by specialised Agencies/Companies. Before starting the laying of foam concrete sample shall be prepared at site and got tested for approval of the Engineer.



The foam concrete laid shall be sufficiently strong to take the usual work loads and standard loads expected on the roof. Any damaged portion shall be removed and replaced forthwith. Approval of the Engineer shall be taken before laying the waterproofing over the insulation.

While laying the foam concrete, sample batches of mix shall be kept for test if so desired by the Engineer.

5.0 MASONRY

5.1 General

This specification deals with masonry and allied works in foundation,

	LAYING, INSTALLATION, TESTING AND COMMISSIONING OF 8” DIA. STEEL GAS PIPELINE CONNECTIVITY IN PATAN GA	
TENDER DOCUMENT NO REPL/SGL/STPL/009/22		Date: -28/11/2022

plinth and superstructure.

5.2 **Materials**

For specifications of materials Part-I shall be referred.

5.3 **Selection of Mortars**

Mortar for masonry shall conform generally to IS: 2250-1981 "Code of Practice for Preparation and Use of Masonry Mortars", and proportion shall be as specified in the drawing or in the Schedule of Items.

5.4 **Cement Mortar**



5.4.1 Cement mortar shall be prepared by mixing cement and sand in specified proportion. It is convenient to take unit of measurement for cement as a bag of cement weighing 50 Kg equivalent to 0.035 cubic metre. Sand is measured in boxes of suitable size (say of 40 x 35 x 25 cm). It shall be measured on the basis of dry volume. In case of damp sand, the quantity shall be increased suitably to allow for bulkage in accordance with IS:2386-1963 (part-III) or by any approved method.

5.4.2 The mixing of the mortar shall be done preferably in a mechanical mixer. This condition may be relaxed by the engineer taking into account the nature, magnitude and location of the work.

If mixed in the mixer, cement and sand in the specified proportion shall be fed in the mixer and mixed dry thoroughly, water shall be then added gradually and wet mixing continued for at least 3 minutes. In case of hand mixing also after mixing dry on a water-tight masonry platform, water shall be added and the mortar turned over and over, backward and forward several times.

5.4.3 Fresh mixed mortar, in case becoming stiff due to evaporation of water may be retempered by adding water as frequently as needed to restore the requirement of the consistency but this shall be permitted only upto a maximum of 2 hours from the time of addition of cement in the mortar.

5.5 **Brick Work**

	LAYING, INSTALLATION, TESTING AND COMMISSIONING OF 8" DIA. STEEL GAS PIPELINE CONNECTIVITY IN PATAN GA	
TENDER DOCUMENT NO REPL/SGL/STPL/009/22		Date: -28/11/2022

5.5.1 Storage and handling bricks

Bricks shall not be dumped at site. They shall be carefully handled and carefully stacked in regular tiers to avoid breakage and defacement of bricks and prevent contamination by mud or other materials. The supply of bricks shall be so arranged that as far as possible at least two days' requirement of bricks is available at site at any time. Bricks selected for different situations of work shall be stacked separately.

5.5.2 Soaking & Cleaning bricks

Bricks required for masonry shall be cleaned to be free from dirt, dust and sand and fully soaked in clean water by submerging in vats before use, till air bubbling ceases. The bricks shall not be too wet at the time of use. After soaking they shall be removed from the tank sufficiently early so that at the time of laying they are skin dry and stacked on a clean space.



5.5.3 Setting out

The building lines shall be set out by the Contractor as per clause 7 of IS: 2212-1991 and got checked by the Engineer.

5.5.4 Laying of bricks



5.5.4.1 Brickwork in general shall be as per IS 2212-1991. Bricks shall be laid in English bond, unless otherwise specified, with frogs upward over a full bed of evenly laid mortar, and slightly pressed and tapped into final position to the lines levels and shape as shown in the drawing fully embedded in mortar. All joints including inside faces shall be flushed and packed. Not more than 8 courses shall generally be laid in a day. The first course itself shall be made horizontal by providing enough mortar in the bed joint to fill up any undulations. The horizontality of courses and the verticality of wall shall be checked very often with spirit level and plumb bob respectively.

5.5.4.2 Horizontal joints shall be truly horizontal and vertical joints shall line up in every alternate course. The joints shall not exceed 10 mm in thickness and shall be well finished and neatly struck. The joints shall be kept uniform throughout the brick work. All the brick joints of the face works shall be neatly raked out to a minimum depth of 15 mm with the help of raking tools and the faces of brick wall cleaned with wire brush to remove any splashes of mortar before the close of the day's

	LAYING, INSTALLATION, TESTING AND COMMISSIONING OF 8" DIA. STEEL GAS PIPELINE CONNECTIVITY IN PATAN GA	
TENDER DOCUMENT NO REPL/SGL/STPL/009/22		Date: -28/11/2022

work, while the mortar is still green and the last brick layer shall be cleaned with wire brush and the frogs free from mortar.

- 5.5.4.3** Walls coming in contact with R.C.C. structures shall perfectly be bonded with M.S. inserts or lugs where shown on drawings and the sides butting against the R.C.C structures neatly and efficiently flashed and packed with rich mortar & cement slurry at no extra cost (cost of M.S. inserts or lugs used shall be measured and paid separately under relevant items). Where such lugs are not required to be provided, brick work shall be built tightly against columns, slabs or other structural parts, around door and window frames with proper distance to permit caulked joint. Where drawings indicate structural steel column or beam to be partly or wholly covered with brick work, bricks shall be built closely against all flanges and webs, with all spaces between steel and brick work filled solid with mortar not less than 10 mm thick.
- 5.5.4.4** Damaged or broken brick or brick bats shall not be used in brick work. Cut bricks may be used to complete bond or as closers or around irregular openings.
- 5.5.4.5** Bricks shall not be thrown from heights to the ground, but shall be handled carefully and put gently in position to avoid damaging their edges.
- 5.5.4.6** Selected bricks of regular shape and dimension shall be used for face work.
- 5.5.4.7** Making of grooves, sleeves and chases shall be done, during the construction, to the lines, levels and position as shown in the drawing or as instructed by the Engineer. Such sleeves shall slope outward in external walls so that their surface cannot form channels for the easy passage of water inside.
- 5.5.4.8** Fixtures, plugs, frames, pipes, inserts etc., if any, shall be built in at the right places to the lines & levels as shown in the drawings while laying the course and not later by disturbing the brick work already laid.
- 5.5.4.9** Brick walls of one brick thick or less shall have one selected face in true plane and walls more than one brick thick shall have both the faces of wall in true plane.
- 5.5.4.10** All connected brick work shall be carried out simultaneously with

	LAYING, INSTALLATION, TESTING AND COMMISSIONING OF 8" DIA. STEEL GAS PIPELINE CONNECTIVITY IN PATAN GA	
TENDER DOCUMENT NO REPL/SGL/STPL/009/22		Date: -28/11/2022

uniform heights throughout the work, and in exceptional cases, with the approval of the Engineer, the brick work built in any part of the work may be lower than another adjoining wall/connected wall by a maximum of one metre and the difference in height of adjoining wall/connecting wall shall be raked back according to bond by stepping at an angle not steeper than 45 degree, without sacrificing the necessary bond, horizontality of layers, verticality of joints and the wall. Tothing shall not be allowed in brick work, for raking back. The top layer just below the R.C.C slab or beam shall be laid with frogs down over a layer of mortar on full width.

5.5.4.11 Openings in brick work

Openings shall be made in brick work, which may be of any shape, size, at all levels, heights or depths, including round openings, as shown in the drawing or as directed by the Engineer, maintaining the necessary bond using a minimum of cut bricks. Openings in external face walls, the sills, jambs, soffits of opening may be rebated and the sill shall be sloped slightly for drainage of rain water.



5.5.4.12 All exposed brick work shall be rubbed down, thoroughly washed, cleaned and pointed as specified. Where face bricks of specific quality are used the same shall be rubbed with carborundum stone.

5.5.5 Half-brick masonry

5.5.5.1 Half-brick work shall be done in the same manner as for brick work except that all courses shall be laid in stretchers. Both faces shall be true to plane and the joints raked on both faces.

Where reinforcement is considered necessary or specified and shown in drawing, M.S. bars or hoop iron shall be provided as stipulated in the Schedule of Items or as directed by the engineer. The reinforcement shall be cleaned of rust and loose scale with a wire brush, and shall be laid straight on the mortar and lapped with the dowel bars provided in the column, securely anchoring them at their ends where the half-brick wall butts. The batching of mortar usually shall be in the proportion of 1:4 or as stipulated in the Schedule of Items. Half of the mortar for the joints shall first be laid and the other half laid after the reinforcement is laid in position, so that the reinforcement is fully embedded in position.

5.5.6 Brick on edge masonry

	LAYING, INSTALLATION, TESTING AND COMMISSIONING OF 8” DIA. STEEL GAS PIPELINE CONNECTIVITY IN PATAN GA	
TENDER DOCUMENT NO REPL/SGL/STPL/009/22		Date: -28/11/2022

The work brick on edge masonry wall in superstructure shall be done in the same manner as mentioned for brick work except that it shall always be reinforced with wire mesh netting of approved variety as specified in the item and embedded in cement mortar at interval as specified in the Schedule of Items. The wire netting shall be continuously laid and securely anchored with the dowel bars provided & projecting from the walls/RCC structure or steel structures at their ends where brick on edge wall butts. The batching of mortar usually shall be in the proportion of 1:3 or as stipulated in the Schedule of Items.

5.5.7 Protection of brick work

The brick wall shall be protected and covered with gunny bags or water proof sheets from the effects of inclement weather, rain, frost, etc., during the construction and until the mortar sets. Care shall be taken during construction that the edges of jambs, sills and soffits of openings are not damaged.



5.5.8 Curing

All brick works shall be kept moist for 10 days after laying.

5.5.9 Scaffolding

5.5.9.1 Necessary and suitable scaffolding shall be provided at all heights to facilitate the construction of brick wall. Scaffolding shall be sound, strong and all supports and other members shall be sufficiently strong and rigid, stiffened with necessary bracings and shall be firmly connected to the walls securing them against swing or sway. Planks shall be laid over the scaffolding at required levels. Scaffolding shall preferably be of tubular steel, although the Engineer may permit other material, depending upon the circumstances.

5.5.9.2 Scaffolding shall be double, having two sets of vertical supports, particularly for the face wall and all exposed brick work. Single scaffolding may be used for buildings upto two storeys high or at other locations, if permitted by the Engineer. In such case the inner ends of horizontal members shall rest in holes provided in header course only. Such holes shall not be allowed in pillars under one metre in width, or immediately near the skew backs or arches. The holes thus left in masonry shall be filled with bricks set in rich mortar and the surface

	LAYING, INSTALLATION, TESTING AND COMMISSIONING OF 8" DIA. STEEL GAS PIPELINE CONNECTIVITY IN PATAN GA	
TENDER DOCUMENT NO REPL/SGL/STPL/009/22		Date: -28/11/2022

made good on removal of scaffolding.

5.5.9.3 If for any reason the Contractor is required to erect scaffolding in property other than that belonging to the Owner, including municipal corporation or local bodies, necessary permission shall be obtained by the Contractor from the appropriate authorities and necessary licensing fees if any shall have to be borne by him.

5.5.9.4 All scaffoldings once erected shall be allowed to remain in position, efficiently maintained by the Contractor, till all the finishing works required to be done are completed and shall not be removed without the approval of the Engineer.

The Contractor shall allow workmen of other trades to make reasonable use of the scaffolding without any extra cost.

5.6 Stone masonry

5.6.1 General



All aspects of the work shall be in conformity with the "Code of Practice for Construction of Stone Masonry, IS: 1597 (Part-I & II)-1992. Relevant clauses under brick work, such as setting out, making chases, openings, fixing frames and plugs, protection, curing, scaffolding etc., shall apply to stone masonry and concrete block masonry.

5.6.2 Mortar

The mortar used shall be as specified in the Schedule of Items or drawing.

5.6.3 Holes and Plugs

Holes in stone walls shall be left for water supply, plumbing, sanitation, electrification, etc., where shown on drawings or ordered by the Engineer as the work proceeds. These holes shall, on completion, be made good to match with the adjoining wall. The Contractor shall provide and fix wooden plugs, water supply piping and electric conduit pipes etc. where so specified.

	LAYING, INSTALLATION, TESTING AND COMMISSIONING OF 8” DIA. STEEL GAS PIPELINE CONNECTIVITY IN PATAN GA	
TENDER DOCUMENT NO REPL/SGL/STPL/009/22		Date: -28/11/2022

5.6.4 Random rubble masonry

5.6.4.1 Laying

All stones shall be wetted and cleaned of all dust and loose materials before laying. Stones shall be laid on their natural beds, fitted carefully to the adjacent stones to form neat and close joints fully packed with mortar and chips and spalls of stone may also be used wherever necessary to avoid thick mortar bed or joints. Walls shall be carried to plumb or to the specified batter. Stones may be brought to level course at plinth, window sills and roof levels and the leveling shall be done with concrete comprising of 1 part of the mortar as used for the masonry and 2 parts of 20 mm down graded hard stone chips at no extra cost. Bond shall be provided by fitting in closely the adjacent stones and by using bond stones running through the thickness of wall in a line from the face to back with at least one bond stone, or a set of bond stones, for every 0.5 sq.m. of the wall surface. Face stones shall extend and bond well into the backing. These shall be arranged to break joints as much as possible, and to avoid long vertical lines of joints.

5.6.4.2 Quoins



Quoins shall be of selected stones, neatly dressed with hammer or chisel to form the required angle and laid header and stretcher alternately. No quoin stone shall be smaller than 0.025cum (25dcum in volume and it shall also not be less than 300mm in length, 25% of them being not less than 500mm in length).

5.6.4.3 Joints

The stones shall be so laid that the joints are fully packed with mortar and chips and face joints shall not be more than 20 mm thick. When plastering or pointing is not required to be done, the joints shall be struck flush and finished at the time of laying, otherwise the joints shall be raked to a minimum depth of 20 mm by raking tool during the progress of work, when the mortar is still green.

5.6.5 Coursed rubble masonry - First sort

5.6.5.1 Laying

	LAYING, INSTALLATION, TESTING AND COMMISSIONING OF 8” DIA. STEEL GAS PIPELINE CONNECTIVITY IN PATAN GA	
TENDER DOCUMENT NO REPL/SGL/STPL/009/22		Date: -28/11/2022

All stones shall be wetted before use. The walls shall be carried up truly plumb or to specified batter. All courses shall be laid truly horizontal and all vertical joints shall be truly vertical. The height of each course shall not be less than 15 cm nor more than 30 cm.

Face stones shall be laid alternate headers and stretchers. No pinning shall be allowed on the face. No face stone shall be less in breadth than its height and at least one third of the stones shall tail into the work for length not less than twice their height.

The hearting or the interior filling of the wall shall consist of stones carefully laid on their proper beds in mortar, chips and spalls of stone being used where necessary to avoid thick beds of joints of mortar and at the same time ensuring that no hollow spaces are left anywhere in the masonry. The chips shall not be used below the hearting stone to bring these upto the level of face stones. The use of chips shall be restricted to the filling of interstices between the adjacent stones in hearting and these shall not exceed 10% of the quantity of stone masonry. The masonry in a structure shall be carried up regularly but where breaks are unavoidable, the joints shall be raked back at an angle not steeper than 45 degree. Tothing shall not be allowed.

5.6.5.2 Bond Stones

Bond stone or a set of bond stones shall be inserted 1.5 to 1.8 metres apart, in every course.



5.6.5.3 Quoins

The quoins, shall be of the same height as the course in which these occur. These shall be at least 45 cm long and shall be laid stretchers and headers alternately. These shall be laid square on the beds, which shall be rough-chisel dressed to a depth of at least 10 cm. In case of exposed work, these stones shall have a minimum of 2.5 cm wide chisel drafts at four edges, all the edges being in the same plane.

5.6.5.4 Joints

All bed joints shall be horizontal and all side joints vertical. All joints shall be fully packed with mortar, face joints shall not be more than one cm thick.

When plastering or pointing is not required to be done, the joints shall

	LAYING, INSTALLATION, TESTING AND COMMISSIONING OF 8” DIA. STEEL GAS PIPELINE CONNECTIVITY IN PATAN GA	
TENDER DOCUMENT NO REPL/SGL/STPL/009/22		Date: -28/11/2022

be struck flush and finished at the time of laying. Otherwise, the joints shall be raked to a minimum depth of 20 mm by raking tool during the progress of work, when the mortar is still green.

5.6.6 Coursed rubble masonry - Second sort

5.6.6.1 Laying

Shall be as specified in 5.6.5.1 except that the use of chips shall not exceed 15% of the quantity of stone masonry, and stone in each course need not be of the same height but more than two stones shall not be used in the height of a course.

5.6.6.2 Bond stone, quoins

Shall be as specified for first sort respectively.

5.6.6.3 Joints

All bed joints shall be horizontal and all side joints vertical. All joints shall be fully packed with mortar, face joints shall not be more than 2 cm thick.

When plastering or pointing is not required to be done, the joints shall be struck flush and finished at the time of laying. Otherwise, the joints shall be raked to a minimum depth of 20 mm by raking tool during the progress of work, when the mortar is still green.



5.7 Hollow concrete block masonry

5.7.1 Construction of hollow concrete masonry shall be done in accordance with procedures laid down in IS: 2572-1963. General procedures for construction shall conform to IS: 2212-1991 except for the following :

5.7.2 Storage, handling and preparation

The blocks shall be stored in stable stacks over planks or other supports with sufficient care taken to prevent ingress or moisture.

Blocks shall be handled carefully to avoid cracking. All damaged units shall be rejected and removed from site. Blocks need not be wetted before or during placement. Unless the climatic condition so require,

	LAYING, INSTALLATION, TESTING AND COMMISSIONING OF 8” DIA. STEEL GAS PIPELINE CONNECTIVITY IN PATAN GA	
TENDER DOCUMENT NO REPL/SGL/STPL/009/22		Date: -28/11/2022

the top and sides may be slightly wetted.

5.7.3 Mortars

Mortar for use in hollow concrete block masonry shall be made from cement, slaked lime and sand unless otherwise specified. The mix preparation shall be as recommended in Table-I of IS: 2572-1963. Preparation of mortar shall be in accordance with IS: 2250-1981.

5.7.4 Laying

Laying of block for first and subsequent courses and requirements of horizontal and vertical joints shall be as described in IS: 2572-1963. Use of hollow blocks in foundations shall be avoided. Use of blocks filled with sand and blocks filled with 1:3:6 concrete for foundation courses, plinths and basements shall be done with approval of Engineer. Closure blocks of superstructure shall have all openings battered with mortar. A course of solid concrete block masonry shall be provided under door and window openings or a 10 cm thick precast concrete sill block shall be provided under windows. This course shall extend at least 20 cm beyond the openings on either side. Solid blocks or hollow blocks filled with 1:3:6 concrete shall be used for jambs or fixing of hold fasts etc., Similarly solid blocks or U-shaped blocks filled with 1:3:6 concrete shall be used for roof course. They shall be finished smooth at top with 1:3 cement mortar and covered with a coat of crude oil, craft paper or oil paper for free roof movement.

5.7.5 Bond



Wherever two walls intersect, bond between at least 50% of the units intersecting shall be provided. If intersecting walls are laid separately pockets shall be left in the first wall at a maximum vertical spacing of 20 cm for the corresponding course of second wall to be built into these pockets.

Pilasters shall be of twice the thickness. Hollow blocks shall not be used for isolated piers unless they are filled with 1:3:6 concrete.

6.0 PLASTERING AND POINTING

6.1 Materials

The specification of materials shall conform to the requirements as

	LAYING, INSTALLATION, TESTING AND COMMISSIONING OF 8” DIA. STEEL GAS PIPELINE CONNECTIVITY IN PATAN GA	
TENDER DOCUMENT NO REPL/SGL/STPL/009/22		Date: -28/11/2022

specified in Part-I.

6.2 Plastering

6.2.1 General

Plastering shall be done in accordance with provisions of IS: 1661-1972. Mix proportions of mortar for plastering and thickness of plaster shall be as given either in the drawing, or as per Schedule of Items or as directed by the Engineer. For special plaster work, necessary admixtures shall be added to mortar in required proportion as per manufacturer's specifications or as specified herein. The thickness mentioned in the Schedule of Items shall be minimum thickness.



6.2.2 Preparation of surface

The surface to be plastered shall be cleaned of all extraneous matter and rubbish. In masonry the joints shall be raked to a minimum depth of 12 mm and cleaned with wire brush. Concrete surfaces to be plastered shall be roughened and hacked to form key for plastering. All plastered surfaces shall be finished smooth with a wooden float in one plane and all internal angles shall be finished slightly rounded. If desired by the Engineer, any unevenness shall be rubbed down by carborundum stones. The surface to be plastered shall be wetted evenly before the application of plastering. Trimming of projections on brick/concrete surfaces wherever necessary shall be done.

For one coat plastering the plaster shall be laid slightly thicker than the specified thickness and the surface then leveled with flat wooden float to the required thickness. For two coat plaster work, the first coat (usually half of total thickness) shall be applied as detailed above except that the surface shall be left rough and keys formed for the application of second coat. The second coat shall be laid on with a wooden float to the specified thickness and shall be applied a day or two after the first coat has set, but has not dried up.

Cement mortar for plastering work shall be used within 30 minutes after adding water to cement and should be kept agitated at intervals of 20 minutes.

If specified cement punning shall be done over the plastered surface by sprinkling neat cement powder evenly on the surface and rubbed

	LAYING, INSTALLATION, TESTING AND COMMISSIONING OF 8" DIA. STEEL GAS PIPELINE CONNECTIVITY IN PATAN GA	
TENDER DOCUMENT NO REPL/SGL/STPL/009/22		Date: -28/11/2022

smoothly with a trowel to give a fine coating. The plaster shall be kept wet for at least seven days and protected from extreme temperature and weather during this period

The arises of doors and windows shall have richer mortar 1:3 in a width of 75 mm on either side or as required at respective location.

6.2.3 Concrete beams, slabs, columns etc. framing into masonry are to be plastered along with masonry walls with these edges wrapped with chicken wire mesh of gauge 24. Overlapping of mesh shall be minimum 75 mm on either side of the edge of the concrete element. Minimum lap for chicken wire mesh shall be 50 mm.

6.3 Cement Pointing

6.3.1 Where shown on drawing, Schedule of Items, or as directed by the Engineer, exposed brick faces shall be cement rule pointed. The mortar shall be raked out of the joints to a depth of 12 mm. The dust shall be brushed out of the joints and the wall well wetted.



Unless otherwise specified the pointing shall be made with cement and sand mixed in proportion 1:3. The joints of the pointed work shall be neatly finished truly vertical and horizontal or as directed and the lines shall be kept wet till the cementing material has set and become hard. If required, the whole brick face shall be rubbed and polished with fine grade of carborundum stones. Particular care shall be taken to see that no brick face or brick edge is damaged during this work.

6.3.2 Flush pointing

The mortar shall be pressed into the joints and shall be finished flush and levelled. The edges shall be neatly trimmed with trowel and straight edges.

6.3.3 Ruled pointing

The joint shall be initially formed as for flush pointing and then, while mortar is still green, a groove of required shape and size shall be formed by running a forming tool straight along the centre line of the joint till a smooth and hard surface is obtained. The vertical joints shall also be finished in similar way. The pointing line shall be uniform in width and truly horizontal in case of floors and ceilings.

	LAYING, INSTALLATION, TESTING AND COMMISSIONING OF 8" DIA. STEEL GAS PIPELINE CONNECTIVITY IN PATAN GA	
TENDER DOCUMENT NO REPL/SGL/STPL/009/22		Date: -28/11/2022

6.3.4 Cut or weather struck pointing

The mortar shall first be pressed into joints. The top of the horizontal joints shall then be neatly pressed back by about 3mm with the pointing tool so that the joint is sloping from top to bottom. The vertical joint shall be ruled pointed. The junctions of vertical joints with the horizontal joints shall be at true right angles.

6.3.5 Raised and cut pointing

This type of pointing shall project from the wall facing with its edges cut parallel so as to have a uniformly raised band about 6mm raised and width 10mm or more as directed. The pointing shall be finished to a smooth but hard surface. the superfluous mortar then shall be cut off from the edges of the lines and the surface of the masonry shall also be cleaned off all the mortar.

Curing

The pointing shall be kept wet for 7 days. During this period it shall be suitably protected from all damages.

6.3.6 Pointing on brick flooring



Specification for this shall be conforming to under sub head "Pointing".

6.3.7 Pointing on random rubble stone masonry

In such pointing, the mortar shall be simply struck off with a trowel and the work left showing the natural irregularities in line and surface of the stones themselves. Other specifications shall remain same as per para 8.3 under sub head "Pointing".

6.4 Rough Cast Concrete Facing

6.4.1 The surface shall be prepared as for Cement plaster and then 2 cm backing coat of cement sand mortar 1:3 shall be applied. Subsequently, when the backing coat is in plastic state, a top coat 12 mm average thick cement and stone chips mixture in proportion 1:3 (stone chips 10 mm size and below) shall be applied by dashing the mixture on top with trowel to produce uniform rough texture. The mix shall again be dashed over the vacant spaces if any. The surface shall afterwards be cured for 10 days. After curing, the surface shall be

	LAYING, INSTALLATION, TESTING AND COMMISSIONING OF 8" DIA. STEEL GAS PIPELINE CONNECTIVITY IN PATAN GA	
TENDER DOCUMENT NO REPL/SGL/STPL/009/22		Date: -28/11/2022

brushed with hard wire brush to remove loose chips from the surface. A coat of cement wash shall then be applied, the cost of which shall be included in the rate of the item.

6.4.2 Rendered sand faced cement plaster

The surface shall be prepared as for cement plaster. The backing coat shall be 12 mm thick of cement plaster proportion 1:4 (1 cement and 4 sand) and keys shall be formed on the surface. After curing this coat sufficiently, the finishing coat 6 mm thick consisting of grey cement and screened coarse sand to required gradation (1:3) shall be applied and finished to the desired texture to the satisfaction of the Engineer. The surface afterwards shall be cured for 7 days.

6.4.3 Plaster moulding



Where specified, plaster moulding shall be strictly as per drawings and details, and shall run clean and true from proper templates and moulds, to the entire satisfaction of the Engineer. Rates shall include for brick or concrete cores and for any necessary dabbing in cement mortar or brick or metal lath curing and final finish as desired. Where desired, all angles in internal moulding work shall be covered to a radius of 50 mm or as directed without any extra charges.

6.4.4 Floating coat with neat cement

When the plaster has been brought to a true surface with the wooden straight edge, it shall be uniformly treated over its entire area with a paste of neat cement and rubbed smooth so that whole surface is covered with neat cement coating. Smooth finishing shall be completed with a trowel immediately and in no case later than half an hour of adding water to cement.

6.4.5 Pebble dash plaster

Specification shall be same as that for rough cast concrete facing vide 8.4.1 except that pebbles or graded crushed stone, of size 10mm to 20mm or as specified/directed by the Engineer, shall be well washed and drained and then dashed/thrown wet on the plaster surfaces while it is still plastic, using strong whipping motion at right angles to the face of wall, pressed flat and filling uncover parts by hand so that finished surface represents homogeneous look. The finished surface shall be

	LAYING, INSTALLATION, TESTING AND COMMISSIONING OF 8” DIA. STEEL GAS PIPELINE CONNECTIVITY IN PATAN GA	
TENDER DOCUMENT NO REPL/SGL/STPL/009/22		Date: -28/11/2022

lightly tapped with a trowel to ensure good bond.

6.5 Punning with Lime or Plaster of Paris

6.5.1 Lime Punning

Lime punning shall be carried out with best quality approved lime. Lime shall be properly stirred, tempered with water to form a homogeneous mass and strained through fine cloth. The punning shall be laid and rubbed and troweled to an uniform smooth even finish using special trowels. Any unevenness shall be rubbed down with fine sand paper. The plaster must be dry before the lime punning is applied. The punning shall be kept wet for a period of 7 days. The lime paste shall be kept wet until use and no more quantity than can be consumed in 10 days shall be prepared at a time. No portion of the surface shall be left out initially to be patched up later on.

6.5.2 Plaster of Paris punning

This shall be provided by using the best quality of plaster of Paris from approved manufacturer. Unless otherwise specified same procedure as for lime punning shall be followed for getting uniform smooth finish.

7.0 FLOORING, PAVING & FACING

7.1 Scope



Flooring, Paving and facing includes flooring, skirting and dado of various types encountered in plants, buildings, pavements etc. as described under respective heads. For the items which have not been covered up in this chapter completely or covered up only partly, specifications suggested by the manufacturers for the materials, surface preparation, workmanship and all other byeworks etc., shall be strictly followed. In addition to this the entire job will have to be carried out as per direction of the engineer, which shall be final.

7.2 Materials

Materials shall conform to Part-I of this series.

7.3 General

Flooring, skirting & dado may have to be done in discontinuous strips

	LAYING, INSTALLATION, TESTING AND COMMISSIONING OF 8” DIA. STEEL GAS PIPELINE CONNECTIVITY IN PATAN GA	
TENDER DOCUMENT NO REPL/SGL/STPL/009/22		Date: -28/11/2022

or areas to suit the needs of erection and commissioning of equipment. Flooring shall be done in close co-ordination with erection of equipment or other services and shall keep pace with the demands in respect of commissioning of individual equipment. No claims for extra shall be tenable for reasons of discontinuity of work or delay in having areas available for work.

Unless otherwise specifically included in the Schedule of Quantities or stated in the description of work, no extra shall be payable for works such as forming coves at internal angles, nosing at plinths, steps, window sills and stair treads, dishing in bath rooms, toilet & other places and cutting to line and fair finish to top edge of skirting and dado. Thickness mentioned shall be the minimum.

7.4 Sub-base

Flooring at ground level having sub-base of sand or earth as specified shall be laid in layers of 15 cm, watered and consolidated by rolling with hand roller or ramming with iron rammer and with butt ends of the crow bars. When filling reaches the required level, the surface shall be flooded with water for 24 hours, allowed to dry and then rammed and consolidated to avoid any settlement later. The thickness of the sub-base shall be as specified either in the drawing or in the Schedule of Items.



7.5 Subgrade

The surface shall be brought to the desired level before subgrade is laid, loose pockets shall be filled up and whole surface shall be consolidated by tamping. Vegetable growth and other decomposed matter, rubbish etc., shall be removed.

7.5.1 Hard core subgrade

Where hardcore subgrade is specified, stone/slag boulders/laterite boulders shall be laid closely stacked together, the longer edge being laid vertically. All interstices shall be filled with smaller particles of the same material or with gravel or red earth. The top surface shall be spread with loose moorum sufficient to cover the gap and to achieve uniform top surface. The surface shall then be adequately watered and rolled by roller.

Hard core shall be laid to form the desired slope in the finished floor.

	LAYING, INSTALLATION, TESTING AND COMMISSIONING OF 8” DIA. STEEL GAS PIPELINE CONNECTIVITY IN PATAN GA	
TENDER DOCUMENT NO REPL/SGL/STPL/009/22		Date: -28/11/2022

7.5.2 Brick Khoa subgrade

Over burnt bricks shall be used for getting brick khoa as per sizes described in Schedule of Items. The khoa shall be laid uniformly and rammed in dry and wet conditions so as to get a uniform compact surface.

7.6 Cement Concrete Flooring with Integral Finish

Cement concrete shall be mixed, laid, consolidated and cured as described in Chapter "Concrete". Laying of concrete shall be done in alternate panels. The size and division of panels shall be as per direction of Engineer. The mix or grade of concrete shall be as specified in Schedule of Items.

The finished surface may be rendered smooth by trowel finishing to provide an appearance of fine and smooth textured surface and in panels or in geometric pattern as specified in Schedule of Items or as directed by Engineer.

**7.7 Concrete Flooring with Granolithic Finish
(Artificial Stone Flooring)**



Granolithic finish shall either be laid monolithically over base concrete or separately over hardened base concrete. The subgrade shall be either brick khoa/lime concrete/cement concrete, as specified. Flooring shall be laid and finished according to IS : 5491-1967.

7.7.1 Thickness

Unless otherwise mentioned the thickness of flooring including topping shall be either 25 mm or 40 mm or 50 mm as shown on drawing/Schedule of Items. The net thickness of topping shall be 6 mm for 25 mm thick floor, 10 mm for 40 mm and 12 mm for 50mm thick floor. An additional allowance of 2mm in thickness of topping shall be made for cutting and grinding margin wherever polishing is specified in the item. The rate of the item will be inclusive of this.

7.7.2 Mix

For base or under bed course, the mix shall be 1:2:4 concrete, unless

	LAYING, INSTALLATION, TESTING AND COMMISSIONING OF 8" DIA. STEEL GAS PIPELINE CONNECTIVITY IN PATAN GA	
TENDER DOCUMENT NO REPL/SGL/STPL/009/22		Date: -28/11/2022

specified otherwise. The mix of the topping shall consist of 1 part cement :1 part coarse sand: 1 part coarse aggregated by volume or 1 part cement and 1 part stone chips. The coarse aggregate shall very hard like granite and well graded and size of chips shall be 3mm for 6mm topping & 6mm to 3mm for 10mm or more thick topping. Minimum quantity of water to get workability shall be added.

7.7.3

Laying



a) Laying of monolithic topping

The concrete base or underbed shall be laid as per specification "Cement Concrete" and levelled upto the required grade. The surface shall remain sufficiently rough to take the finish.

To prevent construction cracks, the panels shall be divided in square or rectangular pattern. For floor finish of 40mm thickness or above, the maximum panel area shall be 2.5 sq.m. with none of the sides exceeding 2.5m, however for lesser thickness these shall be 1.5sq.m. and 2.5m respectively. The dividing strip may be aluminium or glass or as specified and shall have the same depth as that of floor. Within about 2 to 3 hours of laying the base while it is still fully 'green' the topping shall be laid evenly to proper thickness and grade. The topping shall be pressed firmly and rigorously to form full bond with the base/underbed.

The laitance brought to the surface during compression shall be removed carefully without disturbing the stone chips. The surface shall then be lightly troweled to remove all marks and shall be left for sometime till moisture disappears from it. Fresh quantity of cement @ 2.2 Kg per sq.m. of the flooring shall be mixed to form a thick slurry and spread over the surface while concrete is still green. The cement slurry then shall be floated even & smooth. Polishing, if specified, shall be done with polishing machine and the portion where machine cannot be used manually to the satisfaction of the Engineer. If specified so the surface of the flooring shall be finished ribbed, chequered or laid in slope without any extra cost unless specified so in the item. On completion, the floor shall be kept flooded with water for 10 days and shall be adequately protected before it is sufficiently hard.

(b) Laying of topping separately on hardened base

	LAYING, INSTALLATION, TESTING AND COMMISSIONING OF 8” DIA. STEEL GAS PIPELINE CONNECTIVITY IN PATAN GA	
TENDER DOCUMENT NO REPL/SGL/STPL/009/22		Date: -28/11/2022

The sub base shall be laid as in clause 7.7.3. The surface of the base concrete shall be thoroughly brushed and cleaned free from all dirt, mortar droppings and laitance etc.. Where the surface has hardened too much, chipping or hacking of the surface may be necessary. The surface shall then be wetted with water for several hours and surplus water mopped. Neat cement slurry at 2.75Kg/sq.m. of surface shall be brushed into the clean surface. The topping then shall be laid as described in clause 7.9.3.

7.7.4 General

The junction of the floors with all plaster dado or skirting shall be rounded of with 1:1 cement sand mortar & polished, if specified or shown in drawing.

7.7.5 Curing



Immediately after laying, the finish shall be protected against rapid drying. As soon as the surface had hardened sufficiently, it shall be kept continuously moist for at least 10 days by means of wet gunny bags or ponding of water on the surface. The floor shall not be exposed to use during this period.

7.7.6 Grinding & finishing

Where grinding is specified, it shall start only after the finish has fully set. The grinding shall be done with carborundum stone of No. 60, then No. 80 and then 120 as per the method as specified in in-situ mosaic flooring. After final polishing, the floor shall be rubbed with oxalic acid and then wax polished.

7.8 Dado & Skirting Work (Grey Cement Skirting/Dado)

A backing coat of 12 mm thick and 15 mm thick shall be applied on walls after proper dabbing of the surface for a finished thickness of 18 mm and 21 mm thick respectively, with cement plaster of proportion 1:4 (1 cement and 4 approved quality sand) or as specified. Over this a top coat 6mm/7mm thick consisting of one cement to one stone chips 3 mm nominal size shall be applied. If grinding and polishing specified, the same shall be done as per granolithic flooring with carborundum

	LAYING, INSTALLATION, TESTING AND COMMISSIONING OF 8" DIA. STEEL GAS PIPELINE CONNECTIVITY IN PATAN GA	
TENDER DOCUMENT NO REPL/SGL/STPL/009/22		Date: -28/11/2022

stones.

**7.8 Flooring & Facing with Redoxide of Iron
(Red Artificial Stone Flooring)**

It shall consist of an underbed or base course and topping over already laid & matured concrete subgrade.

7.9.1 Thickness

Unless otherwise specified the total thickness of the flooring shall be either 40 mm or 25 mm of which the topping shall not be less than 6 mm (net) for 25 mm thickness and 10 mm (net) for 40 mm thickness. The topping shall be of uniform thickness, the underbed may vary in thickness to provide necessary slopes. For vertical surfaces the total thickness shall be 18 mm, of which the topping thickness shall be 6 mm (net). Where grinding (cutting) & polishing is specified a minimum allowance of 2 mm shall be kept for cutting & polishing so that the net specified top thickness is achieved. All junctions of vertical with horizontal shall be rounded neatly to uniform radius of 25 mm or as shown in the drawing.

7.9.2 Mix



i) Course or base course

The underbed for floors and similar horizontal surfaces shall consist of a mix of 1 part cement, 2 parts coarse sand and 4 parts 10 mm down graded stone chips by volume. For vertical and similar surfaces the mix shall consist of 1 part cement to 3 or 4 parts coarse sand by volume as specified in the item.

ii) Topping course

For the topping white cement and red oxide of iron pigment powder shall be dry mixed thoroughly (generally 10:1 by weight) to produce the desired colour when laid. The mix shall then be prepared with 1 part white cement (mixed with pigment) and 3 parts coarse sand by volume. The whole quantity required for each visible area shall be prepared in one batch to ensure uniform colour.

7.9.3 Laying

	LAYING, INSTALLATION, TESTING AND COMMISSIONING OF 8” DIA. STEEL GAS PIPELINE CONNECTIVITY IN PATAN GA	
TENDER DOCUMENT NO REPL/SGL/STPL/009/22		Date: -28/11/2022

The underbed shall be laid in panels of maximum area 2.5 sq.m. each and no side shall be more than 1.5m long. For outdoor locations the maximum area shall be 2.0 sq.m. or as specified. The forms for the panels shall have perfectly aligned edges to the full depth of the total thickness of finish. Aluminium or glass dividing strips shall be used as forms. The underbed shall be laid compacted, levelled and brought to proper grade with a screed or float. The topping shall be placed after about 24 hours while the underbed is still somewhat 'Green' but firm enough to receive the topping. The surface of the underbed shall be roughhead for better bonding. The topping shall be rolled for horizontal areas and thrown and pressed for vertical areas to extract all superfluous cement and water to achieve a compact dense mass fully bonded with the underbed. The topping shall then be levelled up by troweling and finished smooth with a slurry made with already prepared cement and pigment mixture. About 2.0 kg of the mixture shall be consumed/per sq.m. for horizontal surface, and 1.0 kg for vertical surface.

7.9.4 Grinding & polishing



Where grinding & polishing specified, the same shall be done 36 hours after laying when the surface has hardened sufficiently. It shall be polished with polishing stone, in sequence of different grades of carborundum stones (first No. 60, then No. 80 & then No.120) till a smooth shiny surface to the satisfaction of the Engineer is achieved. After final polishing, the finished areas shall be rubbed with oxalic acid and then wax polished.

7.10 Terrazzo Flooring & Facing

General

The terrazzo work shall be done by approved firm or specialists. Marble chips used for facing coat of terrazzo work shall be of best quality (from Dehradun or other approved source) and of uniform tint and colour and shall be approved by the Engineer before using in the work. All terrazzo work shall be polished on completion followed by a final wax polish of approved quality.

Terrazzo work shall be done either cast-in-situ or with precast tiles as specified in the Schedule of Quantities Unless otherwise specified thickness for cast-in-situ terrazzo work shall be 25 mm including base

	LAYING, INSTALLATION, TESTING AND COMMISSIONING OF 8" DIA. STEEL GAS PIPELINE CONNECTIVITY IN PATAN GA	
TENDER DOCUMENT NO REPL/SGL/STPL/009/22		Date: -28/11/2022

course and for tiles 20 mm excluding mortar bed.

7.10.1 Cast-in-situ terrazzo flooring

It shall consist of an underbed and a topping laid over an already matured concrete subgrade.

7.10.1.1 Thickness

Unless specified otherwise, the total thickness of the finished flooring shall be either 25 mm or 40 mm of which the topping shall be minimum 6 mm (net) for 25 mm and minimum 10 mm net for 40 mm flooring. A minimum allowance of 2 mm in the topping shall be kept for grinding and polishing so as to achieve the minimum specified thickness of topping. All junctions of vertical with horizontal planes shall be rounded neatly to uniform radius of 25 mm or as shown in the drawings.

7.10.1.2 Mix



i) Underbed course

The underbed for floors and similar horizontal surface shall consist of a mix of 1 part cement, 2 parts sand and 4 parts stone chips by volume. The sand shall be coarse. The stone chips shall be 10 mm down well graded. Only minimum water to be added to give a workable consistency.

ii) Topping

Topping shall consist of cement (grey or white) as specified with or without colour pigment, marble powder and marble chips. The proportion of cement and marble powder shall be 3 parts of cement to one part of marble powder by weight. The proportion shall be inclusive of any pigments added to the cement. The proportion to which pigments are mixed with grey or white cement to obtain various shades for the binder, shall be as specified in Table-I of IS : 2114-1984.

The proportion of marble chips and cement marble powder mix shall be 7 parts of marble chips to 4 parts of cement marble powder mix mixed by volume. Care shall be taken to ensure an

	LAYING, INSTALLATION, TESTING AND COMMISSIONING OF 8" DIA. STEEL GAS PIPELINE CONNECTIVITY IN PATAN GA	
TENDER DOCUMENT NO REPL/SGL/STPL/009/22		Date: -28/11/2022

even and uniform disposition of the marble chips.

7.10.1.3 Laying

i) Laying of underbed

The underbed shall be laid in panels in the same manner as that for artificial stone flooring. The panels shall not be more than 2 sq.m. in area of which no side shall be more than 2.0 m long. Cement slurry @ 2.75 kg/sq.m. shall be applied before laying over cement concrete/RCC surface/ plastered surface.



Dividing strips made of aluminium or glass shall be used for forming the panels. The strips shall exactly match the total depth of underbed plus topping. In case of in-situ dado work, the sections shall not be more than 60 cm x 60 cm and the aluminium, glass or any other material strips provided similarly.

ii) Laying of topping

After laying, the underbed shall be leveled compacted and brought to proper grade with screed or float. The topping shall be laid after about 24 hours while the underbed is still somewhat 'green' but firm enough to receive the topping. A slurry of the mixture of cement and pigment already made shall be spread evenly and brushed in just before laying the topping. The topping shall be rolled for horizontal areas and thrown and pressed for vertical areas to extract all superfluous cement and water and to achieve a compact dense mass fully bonded with the underbed. The terrazo surface shall be tamped, troweled and brought true to the required level by straight edge and steel floats in such a manner that maximum amount of marble chips come up and are spread uniformly over the surface and no part of the surface is left without the chips. Excessive troweling should be avoided in early stages lest too much cement may come up the surface leading to surface cracking and requiring more grinding to expose marble chip.

7.10.1.4 Curing

The surface shall be left dry for air curing for about 12 to 18 hours and then cured by allowing water to stand on the surface or by covering

	LAYING, INSTALLATION, TESTING AND COMMISSIONING OF 8" DIA. STEEL GAS PIPELINE CONNECTIVITY IN PATAN GA	
TENDER DOCUMENT NO REPL/SGL/STPL/009/22		Date: -28/11/2022

with wet sack for seven days.



7.10.1.5 Grinding & polishing

Grinding and polishing shall be done either by hand or by machine. In case of manual grinding, the process of grinding shall begin after 2 days while in case of machine grinding the process shall start after seven days after completion of laying. First grinding shall be done with carborundum stone of 60 grit size. The floor shall then be washed and cleaned to remove mud and grindings, a grout of cement and colouring pigment in same proportion of the topping shall be applied to cover the pin holes. The surface shall be cured for 5 to 7 days and then ground with machine fitted fine grit blocks (No. 120). The surface shall be again cleaned and repaired as mentioned above and shall be cured for 3 to 5 days. Finally the third grinding shall be done with machine fitted with fine grit blocks (No. 320) to get even and smooth surface without pin holes. The finished surface should show the marble chips evenly exposed.

Where use of machine for polishing is not feasible/ possible rubbing and polishing by hand shall be done in the same manner as specified for machine polishing except that carborundum of coarse grade (No. 60, 80 and 120) for first, second & final polishing. After the floor is polished to the satisfaction of the Engineer, it shall be rubbed with oxalic acid and finally wax polished with 'Mansion' or similar approved floor polish to the entire satisfaction of Engineer. For good result, wax polishing shall be applied on the surface with the help of soft linen over a clean and dry surface and then the polishing machine fitted with bobs shall be run over it. Clean saw dust shall be spread over the floor surface and the polishing machine again operated so as to remove excess wax and leave glossy surface. Floor shall not be left slippery.

7.10.2 Terrazzo cast-in-situ facing, skirting and dado

The work shall be carried out in the same manner as that for terrazzo cast-in-situ floors except that the base or bedding course shall consist of 1:3 cement mortar (1 cement & 3 medium sand) of 12 mm or 15 mm or 20 mm thickness for total thickness 18 mm or 21 mm or 26 mm respectively. As specified earlier, the bedding course shall be laid in

	LAYING, INSTALLATION, TESTING AND COMMISSIONING OF 8" DIA. STEEL GAS PIPELINE CONNECTIVITY IN PATAN GA	
TENDER DOCUMENT NO REPL/SGL/STPL/009/22		Date: -28/11/2022

panel (not more than 60 cm x 60 cm) divided by glass/ aluminium strips. The topping shall be of 6 mm thick finished and shall be laid when the backing plaster is still green. Special care shall be taken to see that the surface are properly cured.

7.10.3 Terrazzo tile finished flooring/facing

The work will consist of manufactured terrazzo tile and an underbed.

7.10.3.1 Thickness

Unless otherwise specified, the total (net) thickness including the underbed shall be 40 mm for flooring and other horizontal surface and 32 mm for vertical surfaces like dado/skirting. The necessary allowance for cutting and grinding shall be kept to have the specified finished thickness.

7.10.3.2 Tiles : Tterrazzo

The tiles shall, unless specifically permitted in special cases, be machine made under quality control in a shop and shall be subjected to minimum hydraulic pressure of 140 kg. per sq. cm.



The tiles shall be composed of a backing and topping. The finished thickness of upper layers shall not be less than 5mm for size of marble chips upto 6m size and not less than 6mm for size of marble chips upto 20mm size.

The ingredients for topping shall be same as cast-in-situ terrazzo. The thickness of the topping, as specified above, shall be net after grinding & polishing. First grinding shall be given to the tiles at the shop before delivery.

The manufacturer shall supply along with the tiles the grout mix containing cement and pigment in exact proportions as used in topping of the tiles.

7.10.3.3 Mix : Underbed

The underbed for floor and similar horizontal surfaces shall be 1 part lime putty : 1 part surkhi : 1 part coarse sand or 1 part cement : 3/4 parts coarse sand mixed with sufficient water to form a stiff workable

	LAYING, INSTALLATION, TESTING AND COMMISSIONING OF 8” DIA. STEEL GAS PIPELINE CONNECTIVITY IN PATAN GA	
TENDER DOCUMENT NO REPL/SGL/STPL/009/22		Date: -28/11/2022

mass. The thickness of underbed for the flooring shall be 20mm unless otherwise specified. For skirting and dado and all vertical surface it shall be about 12 mm thick and composed of 1 part cement 3 parts coarse sand.

7.10.3.4 Laying

The underbed mortar shall be evenly spread and brought to proper grade and consolidated to a smooth surface. The base surface shall be roughened for better bond. Before laying the underbed, over the base/subgrade, a coat of cement slurry shall be applied over the subgrade. Before the underbed has time to set and while it is still fairly moist but firm, cement shall be hand dusted over it or cement slurry applied at 4.4Kg of cement per sq.m. and the tiles shall immediately be placed upon and firmly pressed by wooden mallet on to the underbed until it achieves the desired level. The tiles shall be kept soaked for about 10 minutes just before laying. The joints between tiles shall be as close as possible and not more than 1.5 mm wide.

Special care shall be taken to check the level of the surface and the lines of the joints frequently so that they are perfect. When tiles are required to be cut to match the dimensions these shall be sawn and edges rubbed smooth. The location of cut tiles shall be planned in advance and approval of the Engineer taken.

At the junction of horizontal surface with vertical surface the tiles on the former shall enter at least 12 mm under the latter.



After fixing, the floor shall be kept moistened allowed to mature undisturbed for 7 days. Heavy traffic shall not be allowed. If desired dividing strips as specified under Cl. 7.10.1.3 may be used for dividing the work into suitable panels.

7.10.3.5 Grinding and polishing

Procedure shall be same as in-situ terrazzo finished flooring. Grinding shall not commence earlier than 14 days after laying of tiles.

7.11 Glazed Tile Finished Flooring & Facing

This finish shall be composed of glazed earthen tiles with an underbed laid over a concrete or masonry base.

	LAYING, INSTALLATION, TESTING AND COMMISSIONING OF 8” DIA. STEEL GAS PIPELINE CONNECTIVITY IN PATAN GA	
TENDER DOCUMENT NO REPL/SGL/STPL/009/22		Date: -28/11/2022

7.11.1 Thickness

Unless specified the total thickness shall be 21 mm for flooring & 18 mm for dado/skirting for the underbed.

The necessary cutting into the surface receiving the finish, to accommodate the specified thickness shall be done.

7.11.2 Tiles : Glazed

These shall conform to the requirement of IS : 777. The tiles shall be of earthenware, covered with glazed white or coloured, plain or with designs, of 149 mm x 149 mm or 99mm x 99mm nominal sizes and 5,6 & 7 mm thick unless otherwise specified. Specials like internal and external angles, beads, covers, cornices, corner pieces etc., shall match. The top surface of the tiles shall be glazed with a gloss or matt unfading stable finish as desired by the Engineer. The tiles shall be flat and true to shape. The colour shall be uniform, and fractured section shall be fine grained in textures, dense and homogeneous.



The coloured tiles, when supplied, shall preferably come from one batch to avoid difference in colour.

7.11.3 Mix : Underbed

The mix for the underbed shall consist of 1 part cement and 3 parts coarse sand mixed with sufficient water or any other mix if specified and shall be 12mm thick minimum or as specified.

7.11.4 Laying & finishing

The underbed mortar shall be evenly spread and brought to proper grade and consolidated to a smooth surface. Before laying the underbed, over the base/subgrade a coat of cement slurry shall be applied over the subgrade. Before the underbed has time to set and while it is still fairly moist but firm, cement shall be hand dusted over it and the tiles shall immediately be placed upon and firmly pressed by wooden mallet on to the underbed until it achieves the desired level. The joints shall be practically invisible and filled with non-staining white cement/white cement mixed with pigment for coloured tiles. Internal angles shall be provided with `specials`. Drains shall be provided with `specials`. The tiles shall be thoroughly cleaned after completion. The tiles shall be laid to the slope specified in the drawings and truly vertical

	LAYING, INSTALLATION, TESTING AND COMMISSIONING OF 8" DIA. STEEL GAS PIPELINE CONNECTIVITY IN PATAN GA	
TENDER DOCUMENT NO REPL/SGL/STPL/009/22		Date: -28/11/2022

on walls when used as skirting.

7.11.5 Curing & cleaning

After flush pointing the joints, the surface shall be cured for 7 days by keeping it wet. The surface shall be then cleaned with soap or suitable detergent, washed fully and wiped with soft cloth to prevent scratching before handing over.

7.12 Marble Flooring

7.12.1 Thickness

Unless specified otherwise the underbed shall be average 20 mm for flooring and 12 mm thick for vertical surfaces. The slabs may be 20 mm, 25 mm, 30 mm or 40 mm thick as specified.

7.12.2 Marble slab



The slabs shall be made from selected stock which are hard, sound, homogeneous and dense in texture and free from flaws, angles and edges shall be true, square, free from chipping and surface shall be plane. The slabs shall preferably be machine cut to the required dimensions. Tolerance of plus or minus 5 mm in dimensions and plus or minus 2 mm in thickness will be allowed. Unless specified the slabs shall be minimum 300 mm x 300 mm. The stone slabs shall come from specific regions and in specified quality with top surface fine chisel dressed. All sides shall also be fine chisel dressed to the full depth to allow finest possible joints.

The slabs shall be delivered to the site well protected against damages and stored in dry place under cover.

7.12.3 Mix : Underbed

The underbed, unless specified otherwise for floor and similar horizontal surfaces shall be 1 part lime putty : 1 part surkhi : 1 part coarse sand or 1 part cement : 4 parts coarse sand mixed with sufficient water to form a stiff workable mass and shall be on 20mm thick bed. For skirting and dado and all vertical surfaces it shall be 12 mm thick and composed of 1 part cement and 3 parts coarse sand.

7.12.4 Laying

	LAYING, INSTALLATION, TESTING AND COMMISSIONING OF 8" DIA. STEEL GAS PIPELINE CONNECTIVITY IN PATAN GA	
TENDER DOCUMENT NO REPL/SGL/STPL/009/22		Date: -28/11/2022

The sides and top surface of the slabs shall be machine rubbed with coarse sand stone and washed clean before laying. The underbed mortar shall be evenly spread and brought to proper level on the area under each slab. The slab shall be laid over the underbed, pressed and tapped down with wooden mallet to the proper level. The slab shall then be lifted and the underbed corrected as necessary and allowed to stiffen a little. Next, a thick cement slurry at 4.4 Kg of cement per sq.m. shall be spread over the surface. The edges of the slab shall be buttered with slurry of cement, grey/ white/mixed with pigment matching the colour of the stone slabs. The slab shall be gently laid and tapped with wooden mallet to bed properly to a very fine joint and to the required level. All surplus cement slurry shall be removed and the surface mopped clean with wet soft cloth. The laid finish shall be cured for 7 days by keeping it wet.

7.12.5 Polishing, finishing



Fine chiseling shall be done to remove the slight undulations that usually exist at the joints. The polishing and finishing shall be done as specified under terrazzo flooring. However, the joints shall be so fine in the case of stone slabs that grouting shall not be called for.

7.13 Marble in Facia or Dado

Marble tiles of approved shade, variety, size and thickness as specified in the item shall be used. They shall be of selected quality, dense, uniform and homogeneous in texture and free from cracks or other structural defects. The exposed face shall have no unsightly stains, veins and defects. They shall have uniform milky white or coloured shade or patterns of colours approved by the Engineer before ordering the tiles. The surface shall be fine polished and sides machine cut, true to square.

When a single course of marble slab is to be fixed as in dado etc., the slabs shall be fixed as described below :

Mortar pads of 1:3 C.M. (1 cement : 3 coarse sand) of uniform width shall be stuck on to the wall at close intervals and the marble slabs shall be pressed on to them firmly. The remaining cavities if any shall then be filled with thin grout of cement mortar of the same proportion. The sound coming, on gently tapping of the slab, will indicate if there are hollows. When the hollow cannot be filled with grout and the finished slab continues to give a hollow sound on tapping, the slab shall

	LAYING, INSTALLATION, TESTING AND COMMISSIONING OF 8" DIA. STEEL GAS PIPELINE CONNECTIVITY IN PATAN GA	
TENDER DOCUMENT NO REPL/SGL/STPL/009/22		Date: -28/11/2022

be removed and reset. For the facia work where more than one course is required the marble slabs shall be of matching stand and veins to form architectural pattern as per drawings and shall be fixed in the same way as described above except for the horizontal joints of the slabs, where adjacent slabs shall be held together by a brass pin passing through a hole drilled into the slabs. In addition, wrought iron/dowels shall be provided to anchor the slabs to the wall. The metal cramps shall be counter sunk into the joints of the slab and it shall be located about a metre apart subject to a minimum of one for each slab for each horizontal joint.

The facing shall be fixed truly in plumb and in perfect line or curves as shown on the plans. The courses and joints shall be as directed by the Engineer. The surface shall be protected from sun and rain and cured for 10 days and shall be finally polished with carborundum stones as for skirting & dado of cast-in-situ terrazzo.

7.14 Flooring/Paving with Hardener like Ironite

This will consist of a topping (incorporating iron particles) to bond with concrete base while the latter is 'Green'.

7.14.1 Thickness



Unless otherwise specified in the Schedule of Items, the total thickness of the floor with metallic hardener finish shall be 40 mm or 50 mm of which the topping shall be 10 mm (net) for 40 mm & 12 mm (net) for 50 mm

7.14.2 Material (metallic hardener)

The hardening compound shall be uniformly graded iron particles free from non-ferrous metal impurities, oil, grease, sand soluble alkaline compounds or other injurious materials. When desired by the Engineer, actual samples shall be tested.

7.14.3 Mix

Unless otherwise specified, the mix for underbed shall be of 1:2:4 concrete and stone chips shall be 12 mm down grade. For topping the proportion of the metallic hardener shall be as specified or as indicated by the manufacturer. However, in absence of any such direction 1 part

	LAYING, INSTALLATION, TESTING AND COMMISSIONING OF 8" DIA. STEEL GAS PIPELINE CONNECTIVITY IN PATAN GA	
TENDER DOCUMENT NO REPL/SGL/STPL/009/22		Date: -28/11/2022

metallic hardener shall be mixed dry with 4 parts cement, by weight.

To this mixture 6 mm nominal size stone chips shall be added in proportion of 1 part cement (mixed with hardener) to 2 parts of stone chips by volume and uniformly mixed. Minimum quantity of water shall be added to make it workable.

7.14.4 Laying & finishing

The under bedding course of base course shall be laid as per specification of laying underbed for Red artificial stone flooring. The surface shall be roughened by wire brush as soon as possible. The finish top coat shall be laid while the concrete base is still fairly 'green' within about 3 hours of laying of the later. The finish shall be of uniform and even dense surface without trowel marks, pin holes etc. This topping layer shall be pressed firmly and worked vigorously and quickly to secure full bond with the concrete base. Just when the initial set starts the surface shall be finished smooth with steel trowel.

7.14.5 Curing

The finished floor shall be cured for 7 days by keeping it wet.



7.15 Chemical Resistant Tiles Flooring / Facing (Either of natural stone or prepared tiles)

This shall include all varieties of special tiles used for specific chemical resistance function and an underbed over already laid concrete or masonry. The Contractor shall get it done by specialised manufacturer & get guarantee of its performance.

7.15.1 Tiles

The chemical resistant tiles as detailed in the Schedule of Items shall be of the best indigenous manufacture unless otherwise specified and shall be resistant to the chemical described in the Schedule of Items. The tiles shall have straight edges, uniform thickness, plain surface, uniform non-fading colour and textures.

Usually the chemical resistant tiles shall not absorb water more than 2% by weight. The tiles shall have at least compression strength of 700 kg/cm². The surface shall be abrasion resistant and durable.

	LAYING, INSTALLATION, TESTING AND COMMISSIONING OF 8" DIA. STEEL GAS PIPELINE CONNECTIVITY IN PATAN GA	
TENDER DOCUMENT NO REPL/SGL/STPL/009/22		Date: -28/11/2022

7.15.2

Laying

The mortar used for setting or for underbed the tiles shall be durable and strong. The grout which shall be to the full depth of tile shall have same chemical resistant properties as that of tiles. Joints shall be pointed if so desired. The setting and fixing shall be according to the manufacturer's specification approved by the Engineer.

7.16

Chemical Resistant in Situ Finished Flooring/Facing

Chemical resistant in situ finish shall be as called for in the Schedule of Items. About its performance the Engineer shall have to be fully satisfied by test results and examination of similar treatment already in existence. The Contractor shall get it done by a specialised manufacturer, get guarantee of performance from the organisation and pass it on to the owner in addition to his own guarantee.

7.17

Acceptance Criteria

The Contractors shall satisfy the Engineer specially for the workmanship of the following finished floor :

- (a) Level, slope, plumb as the case may be
- (c) Alignment of joints, dividing strip etc.
- (d) Colour, texture
- (e) Surface finish
- (f) Thickness of joints including the workmanship in joints.
- (g) Details at edges, junctions etc.
- (h) Performance
- (i) Precautions specified for durability.
- (j) Effluent treatment plant



8.0

WOOD WORK

8.1

General

Wood work shall be neatly and truly finished to exact dimensions and details as per drawings, without patching or plugging of any kind. Rebates, roundings and mouldings as shown in drawings shall be

	LAYING, INSTALLATION, TESTING AND COMMISSIONING OF 8” DIA. STEEL GAS PIPELINE CONNECTIVITY IN PATAN GA	
TENDER DOCUMENT NO REPL/SGL/STPL/009/22		Date: -28/11/2022

made before assembling. Exposed work shall be finished smooth with well planed faces.

All assembly of shutters of doors, windows, ventilators and frames thereof shall be exactly at right angles. In the case of frames, the right angle shall be checked from the inside surfaces of the respective members.

All door and window frames shall be clamped together so as to be square and flat at the time of delivery. Door frames without sills shall be fitted with temporary stretchers.



Horns of frames and other parts that go into or butt against the masonry, shall be protected against moisture and decay with two coats of coal tar or other approved protective material.

All surfaces of the door, window and ventilator frames and shutters which are required to be painted ultimately shall be covered evenly by brush with a priming coat of approved primer. In the case of doors to be polished or varnished, a priming coat of approved polish or varnish shall be given before delivery. No primer shall be applied to the wood work until it has been inspected and passed by the Engineer.

8.2 Joinery

All heads, posts, transoms and mullions etc., of doors, windows and ventilators shall be made out of single pieces of timber only. The heads and post shall be through- tenoned into the mortices of the jamb posts to the full width of the latter and the thickness of the tenon shall be not less than 1.25 cm. The tenons shall be close fitting into the mortices and pinned with corrosion resisting metal pins not less than 8 mm diameter or with wood dowels not less than 10 mm diameter. The depth of rebate in frames for housing the shutters shall in all cases be 1.25 cm and the rebate in shutters for closing in double shutter doors or windows shall be not less than 2 cm. Unless otherwise specified, all joints shall be mortice and tenon joints with the ends of the tenons exposed to view. Joints shall fit truly and fully without fillings. The contact surfaces of tenons and mortices shall be treated, before putting together, with an approved adhesive conforming to I.S :848- 1974 and 851-1978.

8.3 Shrinkage & Tolerance

	LAYING, INSTALLATION, TESTING AND COMMISSIONING OF 8” DIA. STEEL GAS PIPELINE CONNECTIVITY IN PATAN GA	
TENDER DOCUMENT NO REPL/SGL/STPL/009/22		Date: -28/11/2022

The arrangement, joining and fixing of all joinery work shall be such that shrinkage in any part and in any direction shall not impair the strength and appearance of the finished work.

The tolerance on overall dimensions shall be within the limits prescribed in IS : 1003 (Part 1 & 2)-1983 to 1991.

8.4 Fixing

Door and window frames shall generally be built in at the time the walls are constructed. Alternatively, where permitted by the Engineer, the frames may be subsequently fixed into prepared openings for which purpose holes to accommodate the holdfasts shall be left at the time of construction. Where the frames are subsequently fixed into prepared openings in the wall such openings should be 25 mm more than the overall width of the door, window or ventilator frame to allow minimum 12mm plaster on each jamb. The height of the unfinished opening shall depend upon whether a threshold is required or not. While fixing the door care shall be taken to see that at least 6 mm space is left between the door and the finished floor. The M.S. clamps fixed to the frame shall be inserted in the holes and jammed in cement concrete M-15 or (1:2:4 mix) with 20 mm down graded stone chips after holding the frame in proper position to the line, level and plumb.



The size of the concrete block shall be 250 x 125 x 85mm unless otherwise specified.

8.5 Tarring

Timber in contact with earth, concrete, plaster or masonry shall be treated with boiling coal tar or 2 coats of wood preservative treatment like hot solignum or creosote oil etc. before fixing the frame in position.

8.6 Fittings

Unless otherwise specified, three holdfasts shall be fixed on each side of a door frame, one at the centre point, and the other two at 30 cm from the top and the bottom of the door frames. In the case of windows and ventilators, a pair on each side shall be fixed at quarter points of the frames. Unless otherwise specified the hold-fasts shall be of mild steel plate 40 x 3 x 225 mm long, fish tailed at one end and screwed to the frame in the formed rebates.

	LAYING, INSTALLATION, TESTING AND COMMISSIONING OF 8” DIA. STEEL GAS PIPELINE CONNECTIVITY IN PATAN GA	
TENDER DOCUMENT NO REPL/SGL/STPL/009/22		Date: -28/11/2022

Generally, each door shutter shall be fixed to the frame with three hinges of approved manufacture, one at the centre and the other two approximately 24 cm from the top and bottom of the shutter. Each window shutter shall be fixed to its frame with two hinges at the quarter points.

Locks, handles, door closers, stoppers etc., shall be fitted as shown in drawing or described in the Schedule of Items.



8.7 Doors, windows & ventilators etc.

Dimensions of the various components of doors, windows and ventilators shall be in accordance with IS : 1003 (Part 1&2)-1983 to 1991 Table- III or as shown on the drawings. The work shall be carried out as per detailed drawing. The wooden members shall be planed, smooth and accurate. They shall be cut to the exact shape and size without patching or plugging of any kind. Mouldings, rebates, curves and roundings etc. shall be done as shown in the drawing before the pieces are assembled into the shutter.

The thickness of stiles and rails etc shall be as per IS: 1003 (Part 1&2)-1983 to 1991 unless otherwise specified in the item of works. These shall be properly and accurately mortised and tenoned. Rails which are more than 180mm in width shall have 2 tenons. Stiles and rails shall be made out of single piece upto 200mm in width. In case more than one piece of timber is used for members exceeding 200mm width, they shall be joined with a continuous tongued and grooved joint, glued together and reinforced with rust proof metal dowels or headless pins. The tenons shall pass clear through stiles. the stiles and rails shall have a 12mm groove, unless otherwise shown in the drawing, to receive the panel. In case of double shutters the rebate at the closing junction of the two shutters shall be as per clause 5.5 of IS: 1003-1991 or as shown in the drawing. Primer coat shall not be put before shutters are passed by the engineer.

8.8 Panelled Shutters

These shall conform to IS: 1003 (Part I)-1991. Timber panelled shutters shall be constructed in the form of timber frame work of stiles and rails with panel inserts of timber, plywood, block board, veneered particle board, hard board or asbestos cement board.

	LAYING, INSTALLATION, TESTING AND COMMISSIONING OF 8” DIA. STEEL GAS PIPELINE CONNECTIVITY IN PATAN GA	
TENDER DOCUMENT NO REPL/SGL/STPL/009/22		Date: -28/11/2022

Stiles, rails and panels in door shutters shall be of the same species of wood.

Timber panels shall be of minimum width of 150mm. When made from more than one piece, the pieces shall be jointed with a continuous tongued and grooved joint, glued together and reinforced with metal dowels. No single panel shall exceed 0.5 m² in area. Timber panels shall be fixed only with grooves but additional beadings may be provided either on one side or both sides.

Unless otherwise specified thickness of panel for 35mm thick shutter shall be 15mm and for 40mm and above thick shutter, it shall be 20mm. For 25mm thick shutter, panel thickness shall be 12mm.

Apart from timber panels other materials like plywood, Block board, particle board, Hard board and Asbestos cement may also be used for panelling purpose and shall be fixed with grooves or beading or both as per provisions made in IS:1003 (Part-1)-1991.



Timber suitable for manufacture of door shutter have been grouped under class a,b,c & d in Table 1 of IS: 1003 (Part-1)-1991.

8.9 Glazed Shutters

The openings for glazed shutters shall be rebated and moulded out of solid timber. Plain sheet glass for panels shall be of approved quality as specified. Wherever specified, ground glass or frosted glass of approved quality shall be used in place of plain sheet glass. Unless otherwise specified glass panes shall be fixed by means of moulded beads and suitable MS panel pins. A thin layer of putty shall be applied between glass panes and sash bars and also between glass panes & beading.

8.10 Flush Door Shutters

Unless otherwise specified, flush door shutters shall have a solid/cellular core, a teak wood frame, and shall be faced with approved quality of plywood on both faces. The core and stock shall be made from well seasoned approved timber and treated with approved preservatives. The plywood faces shall be glued on to the solid/cellular core with waterproof glue under pressure and heat. The construction of flush doors shall be such that no difficulty should arise

	LAYING, INSTALLATION, TESTING AND COMMISSIONING OF 8” DIA. STEEL GAS PIPELINE CONNECTIVITY IN PATAN GA	
TENDER DOCUMENT NO REPL/SGL/STPL/009/22		Date: -28/11/2022

in fixing mortice locks, hydraulic door closers etc. The shutters shall be rebated in the case of the double leaf doors. Where specified flush doors shall be provided with vision panels, rectangular/ round or louvered.

If specified so, the flush door shall be solid block board core or solid particle board core construction. The workmanship and overall finish shall be of very high standard and shall conform to IS:2191 (Part 1&2)-1983 & 2202 (Part 1&2)-1983 to 1991. The shutters shall be procured from approved manufacturer bearing IS certification mark only.

8.11 Other types of shutters

8.11.1 Wooden hand rails



Wooden hand rails shall be of approved quality teak wood fixed to concrete or metal balustrade with concealed steel or metal lugs and bolts as per drg. Joints will be made with concealed crews and dowels. All bends, mitres, coves, moulds etc. will be strictly to proper profile and finally smoothed by sand paper. The hand rail shall be finished with wax or french polish or painting as per direction of the engineer.

8.11.2 Hardware fittings for door, windows & ventilators

All mortice or rim locks, latches, cabinet and wardrobe locks, hydraulic door closers, floor springs etc. shall be of Godrej, Everite make or of similar approved make. The rate shall include for all necessary screws, other adjuncts, fixing in position and is for the completed work. the finish shall be as specified in the schedule of quantities. Door, window and ventilator fittings shall be as per specifications already described. The rates for doors, windows and ventilator shutters shall include the cost of fixing the fittings, with the necessary screws to the shutters and the frame. The cost of fittings only shall be paid separately. Where specified in the schedule of quantities, the cost of fittings shall be included in the rates for doors, windows and ventilators shutters. In such case the contractor shall supply and fix the various fittings strictly to the standard laid down in the schedule of hardware fittings and no separate payment for this shall be made.

8.12 Inspection

The Contractor shall provide all facilities to the Engineer for the inspection of the goods at his premises. No primer shall be applied

	LAYING, INSTALLATION, TESTING AND COMMISSIONING OF 8" DIA. STEEL GAS PIPELINE CONNECTIVITY IN PATAN GA	
TENDER DOCUMENT NO REPL/SGL/STPL/009/22		Date: -28/11/2022

until the wood work has been inspected and passed by the Engineer.

The Engineer shall have the option of rejecting any article or asking for replacement of any article found to be defective or not complying with the requirements of this specification and the relevant Schedule of Items.

9.0 METAL DOORS, WINDOWS AND ROLLING SHUTTERS

9.1 General



Doors, windows and ventilators etc., shall be truly square and flat, i.e. free from twist and warp. The general fabrication shall conform to IS:1038-1983 & IS : 1361-1978 as applicable.

9.1.1 Frames shall be constructed of sections which have been cut to length and mitred. They shall be morticed, reinforced, drilled and tapped for hinges and lock and bolt strikes. Where necessary, frames shall be reinforced for door closers. Flash butt welding or any other suitable method which gives the desired requirement, with mitred corners shall be used. Rubber door silencers shall be furnished for the striking jamb. Loose "T" masonry anchors shall be provided. Frames shall finish flush with floor and adjustable floor anchors shall be supplied. Frames shall be brought to site with floor ties/weather bars installed in place. All frames shall be square and flat. Door thresholds shall be provided as shown on drawing. Doors without threshold shall have bottom tieoff approved type.

9.1.2 The Contractor shall first submit for the approval of the Engineer, the name and address of the manufacturer whose metal casements and doors and windows he intends to use, together with typical drawings and specifications, describing the details of construction for each type of door/window/ventilator etc.

9.1.3 All steel doors, windows and ventilators shall be either galvanised or painted. All steel surfaces shall first be thoroughly cleaned free of rust, scale or dirt and mill scale by pickling or similar process and then shall be painted with one coat of an approved primer conforming to IS : 102-1962 before despatch. Alternatively they may be galvanised by the "Hot Dip" zinc spray or electro- galvanizing process as described in IS : 1361-1978.

9.2 Fixing

	LAYING, INSTALLATION, TESTING AND COMMISSIONING OF 8” DIA. STEEL GAS PIPELINE CONNECTIVITY IN PATAN GA	
TENDER DOCUMENT NO REPL/SGL/STPL/009/22		Date: -28/11/2022

Doors, windows and ventilators shall not be built in at the time the walls are constructed but shall be subsequently fixed into prepared openings, as laid down in IS : 1081-1960. Holes to accommodate the fixing lugs are to be left or cut, and the casements fixed after all the rough masonry and plaster work have been finalised. The lugs of the casement shall be jammed in cement concrete (15C Mark)/(1:2:4) mix after holding the casement in proper position, line and level.



The width of the clear unfinished opening in the wall should be 25 mm more than the overall width of the door frame to allow for plaster on each jamb. The height of the unfinished opening shall depend upon whether a threshold is required or not. While fixing the door, care shall be taken to see that at least 6 mm space is left between the door and the finished floor.

9.3 Fittings

Hardware shall be fixed as late as possible, preferably just before the final coat of paint is applied. It shall be fitted in a workmanlike manner, so that it may not work loose and in such a way that screws and pins are not marked and mutilated by hammers and screw drivers. It shall be tested for correct operation. Where specified, doors shall be fitted with a three-way bolting device which can be operated from outside as well as inside, and a locking system, which can similarly be operated from either side. Solid steel bolt handles shall be provided, one on the outside and one on the inside of each shutter. In case of doors provided with a service door, the lock shall be fitted on the service door. All materials shall be the best procurable and shall be approved by the Engineer.

9.4 Normal Steel Plate Doors

Steel doors may be of the hinged type or sliding/ folding type, single shutter or double shutter, and of single-walled or double walled construction, as specified on the drawings or Schedule of Items. All doors shall be provided with a sturdy frame and hold fasts for fixing into the wall. Unless otherwise specified, the frame shall be prepared from mild steel angles of size not less than 65 x 65 x 6 mm electrically welded at the corners and the shutter shall be made from flat steel sheet of 18 gauge or 1.25mm thickness with a frame of mild steel angles not less than 50 x 50 x 6 mm all round, suitably braced. The whole shutter shall be of welded construction and shall be hung at the

	LAYING, INSTALLATION, TESTING AND COMMISSIONING OF 8" DIA. STEEL GAS PIPELINE CONNECTIVITY IN PATAN GA	
TENDER DOCUMENT NO REPL/SGL/STPL/009/22		Date: -28/11/2022

sides by means of three or four hinges as specified.

9.4.1 Double Plate flush door shutters

Door shutters shall be 45 mm thick, completely flush design and shall comprise of two outer sheets or 18G or 1.25mm thick steel sheets, rigidly connected and reinforced inside with continuous vertical 20G or 0.99mm thick stiffeners, spot welded in position at not more than 150 mm on centres. Both edges of doors shall be joined and reinforced full height by steel channels placed immediately inside and welded to the door faces. Top and bottom of doors shall be reinforced horizontally by steel channels running full width of door. Doors shall not have more than 2.5 mm clearance at jambs and head, shall have proper level on lock stiles and rails and shall be reinforced at corners to prevent sagging or twisting. Pairs of double doors shall have meeting style edges bevelled or rebated. Where shown on drawing, or in the Schedule of Items, the doors shall be sound-deadened by filling the inside voids with mineral wool or other suitable approved materials. Doors shall be mortised, reinforced, drilled and tapped in shop for hinges, locks and bolts. They shall also be reinforced for closers, push-plates and other surface hardwares where necessary. Any drilling and tapering required for surface hardware shall be done at site. Where shown in drawing, provisions, shall be made for fixing glazing, vision panels, louvres etc. Glazing mouldings shall be of 18G or 1.25mm thick steel or extruded aluminium sections with profiles shown in drawing and suitable for fixing 6 mm glass. Louvre blades shall be V or Z shaped sections.



9.4.2 Single sheet door shutters

Single sheet doors shall be made from best quality 18g/1mm mild steel sheets, and shall present a flush surface on the outside. The inside shall be stiffened with a semi-tubular edge and central stiffening rail which shall convey the lock and other fixture. The frames shall be made from best quality steel sections. Wherever required or shown on drawings, provision for fixing glass panes, louvres etc., shall be made.

The manufacturing shall done as specified in "Double Plate Flush Door Shutters".

9.5 Pressed Steel Doors

All pressed steel doors shall be obtained from an approved

	LAYING, INSTALLATION, TESTING AND COMMISSIONING OF 8” DIA. STEEL GAS PIPELINE CONNECTIVITY IN PATAN GA	
TENDER DOCUMENT NO REPL/SGL/STPL/009/22		Date: -28/11/2022

manufacturer. The frame and shutters shall be fabricated from cold rolled or pressed steel sections. Unless otherwise specified, the thickness of all sheets used for frames shall be not less than 5 mm. The shutters shall be made of sheet steel of 2 mm thickness for single shutter doors and double shutter doors with or without service door. The plates shall be adequately stiffened with suitably placed stiffeners

The double-walled door shutter shall consist of two plates each 2.5 mm thick, separated by a gap of 33 mm in between making an overall thickness of 38 mm or as shown in drawing. The plates shall be adequately stiffened by means of suitably spaced horizontal steel stiffeners.

9.6 Steel Windows, Sashes, Ventilators, etc.

These shall conform to IS : 1038-1983 and IS : 1361-1978 as appropriate and as shown in drawings. The details as called for in the above codes shall be applicable for coupling mullions, transoms, weather bars, pivot arrangements for ventilators, etc.

9.6.1 Where composite unit openings are shown in drawings, the individual window units shall be joined together with requisite transoms and mullions. Where aluminium glazing beads are specified, they shall be extruded aluminium channel 9.5 mm x 1.6 mm (Indal Section No. 2209) unless otherwise shown in drawings.



All welds at the corner of casement shall be done by flash butt welding process or any other suitable method which gives the desired requirement and dressed flush on all exposed and contact surfaces.

9.7 Collapsible Gate (Steel)



Mild steel collapsible gates shall be obtained from an approved manufacturer. These shall be of mid bar type made out of double channels each 20 x 10 x 2 mm with 20 x 5 mm diagonals and shall be top hung with roller bearings, and fitted with locking arrangement.

Collapsible gates under 3.0 metre height shall generally have 3 sets of lattices and those over 3.0 metre height, 4 sets of lattices. Guide tracks shall be fitted at the top and bottom, of T-iron 40 x 40 x 6 mm with 40 mm dia bearings in every fourth double channel

9.8 Steel Rolling Shutters and Grills

	LAYING, INSTALLATION, TESTING AND COMMISSIONING OF 8" DIA. STEEL GAS PIPELINE CONNECTIVITY IN PATAN GA	
TENDER DOCUMENT NO REPL/SGL/STPL/009/22		Date: -28/11/2022

- 9.8.1 Unless otherwise specified the shutters shall conform IS:6248-1979. Laths for rolling shutters shall be made from tested bright cold rolled, annealed M.S. strips, not less than 0.9 mm thick for shutters upto 3.5 M wide and not less than 1.25 mm thick for shutters above 3.5 M wide and machine rolled at 75 mm rolling centres, interlocking with each other. The profile will be such as to prevent excessive deflection under specified wind load.
- 9.8.2 Rolling grills shall be constructed out of 6/8 mm dia rods at 35 mm on centres running horizontally flexible connected with vertical links spaced not more than 200 mm centres. Alternatively, rolling grills shall be made from perforated laths of approved design reinforced with 6 mm dia rods. End locks shall be heavy type and shall be provided at each end of alternate laths unless specified otherwise. Bottom bars shall be finished with two angles not less than 6 mm thick for external shutters. When shown in drawings, a flexible weather strip shall be applied to make tight contact with the floor. Guides shall be of such depth as to retain the shutter under a wind pressure of 150 kg/sq.m. or as specified. Shafts shall be of steel pipe of sufficient size to carry the torsional load with a maximum deflection of 1/360 th of span. Grease packed ball bearings or bushings shall be provided for smooth trouble free operation. Hoods shall be formed of not less than 20 gauge or 0.90 mm thick sheet mild steel, suitably, reinforced to prevent sag. Locks shall be slide bolt and hasp, or cylinder lock operable from both sides. Provision for securing hand chain with padlock, removable handle for hand cranks etc, shall be made as described in scheduled of items and as directed by the Engineer.
- 9.8.3 **Laths for rolling shutters shall be made from tested bright cold rolled, annealed M.S. strips, not less than 0.9 mm thick for shutters upto 3.5 M wide and not less than 1.25 mm thick for shutters above 3.5 M wide and machine rolled at 75 mm rolling centres, interlocking with each other. The profile will be such as to prevent excessive deflection under specified wind load. Rolling grills shall be constructed out of 6/8 mm dia rods at 35 mm on centres running horizontally flexible connected with vertical links spaced not more than 200 mm centres. Alternatively, rolling grills shall be made from perforated laths of approved design reinforced with 6 mm dia rods.**
- 9.8.3 End locks shall be heavy type and shall be provided at each end of alternate laths unless specified otherwise. Bottom bars shall be

	LAYING, INSTALLATION, TESTING AND COMMISSIONING OF 8" DIA. STEEL GAS PIPELINE CONNECTIVITY IN PATAN GA	
TENDER DOCUMENT NO REPL/SGL/STPL/009/22		Date: -28/11/2022

finished with two angles not less than 6 mm thick for external shutters.

When shown in drawings, a flexible weather strip shall be applied to make tight contact with the floor. Guides shall be of such depth as to retain the shutter under a wind pressure of 150 kg/sq.m. or as specified. Shafts shall be of steel pipe of sufficient size to carry the torsional load with a maximum deflection of 1/360 th of span. Grease packed ball bearings or bushings shall be provided for smooth trouble free operation. Hoods shall be formed of not less than 20 gauge or 0.90 mm thick sheet mild steel, suitably, reinforced to prevent sag. Locks shall be slide bolt and hasp, or cylinder lock operable from both sides. Provision for securing hand chain with padlock, removable handle for hand cranks etc, shall be made as described in scheduled of items and as directed by the Engineer.

9.8.5 Manually operated shutters/grills

Manually operated shutters shall be easily operable by one person. The speed of operation shall be about 0.3 metres per second. In general, manually operated shutters shall be push pull type for openings upto 9 sqm in area. Larger shutters shall be either chain and gear operated or crank and gear operated. The crank/handle shall be removable. All shutters shall be lockable from one or both sides as described in Schedule of Item or as desired by the Engineer.



9.8.6 Priming coat of shop coat

Shutters shall be painted with one coat of red lead or zinc chromate primer after they are inspected and found in order and acceptable. Where specified, doors shall be galvanized and subsequently painted one coat of zinc chromate for adhesion of field coat.

9.8.7 Erection

Door shall be installed by the manufacturer or his authorised representative and all work shall be as per manufacturer's instructions. Any drilling or cutting to concrete, masonry etc., shall be made good after erection of shutters and all abrasion to shop coat shall be touched up. All electrical work shall be in strict accordance with prevailing Indian Electricity Rules.

9.8.8 Inspection

	LAYING, INSTALLATION, TESTING AND COMMISSIONING OF 8” DIA. STEEL GAS PIPELINE CONNECTIVITY IN PATAN GA	
TENDER DOCUMENT NO REPL/SGL/STPL/009/22		Date: -28/11/2022

After completing the manufacture of the different components of the rolling shutter, an arrangement for shop inspection by the Engineer shall be made to check the conformity with approved shop drawings.

9.8.8.1 Field inspection

After installing the shutters, the Contractor shall test the performance of the shutter in the presence of the Engineer. The doors shall be smoothly operable under all ambient conditions. All control and locking devices shall give fault-free performance.

9.9 Guarantee

The Contractor shall give one year's guarantee for the successful operation of the shutters. This shall be supported by a separate and unilateral guarantee from the manufacturer of the shutters.



9.10 Aluminium Doors, Windows, Frames

9.10.1 Anodised tubular aluminium doors shall be of approved make and shall be of size and design as per relevant drawing. Unless otherwise specified, the door frame shall be of 101.4mm x 44.6mm and shutter of 50mm tubular extrusions, 3mm thick. The opening arrangement shall be single action or double action as shown in drawing with spring hinges in floor. The glazing shall be 5.5mm thick plain glass panes fixed with necessary gaskets and aluminium beading strip. The door shall be provided with one security lock. The shutters shall be provided with 1.6mm thick 300x150mm push plates and 1.6mm thick 300mm wide kick plate of anodised aluminium for full width of door inside and outside.

The door frames shall be polished and anodized with approved colour. The average thickness of anodic coating shall not be less than 15 microns as per IS: 1868-1982. Door frame shall be provided with approved anchors @ 90 cm c/c maximum for fixing.

9.10.2 Aluminium windows

Aluminium windows and ventilators shall conform to IS:1948-1961 or equivalent as approved by the Engineer. Fixed frame shall be manufactured from aluminium alloy conforming to ISS-HE-9 WP. The

	LAYING, INSTALLATION, TESTING AND COMMISSIONING OF 8” DIA. STEEL GAS PIPELINE CONNECTIVITY IN PATAN GA	
TENDER DOCUMENT NO REPL/SGL/STPL/009/22		Date: -28/11/2022

fixtures like handles, stoppers, stays, etc., shall also be anodized aluminium and shall be of approved make. Glazing shall be 4mm thick plain glass and shall be fixed with glazing clips and metal putty. It shall conform to IS:1081-1960. Average anodizing coating to windows, ventilators and fixtures shall not be less than 15 microns as per IS : 1868 - 1982.

9.10.3 All work shall be fitted and shop assembled to a first job, and ready for erection. Shop joints shall be made to hair lines and then welded or braced by such method as will produce a uniform colour throughout the work. Wherever possible, joints shall be made in concealed locations and on edges of doors. Field connections of all work may be made with concealed screws or other approved type of fasteners. Glazing beads shall be shape fit type without visible screws and shall be of sizes to accommodate glazing. All work shall be adequately braced and reinforced as necessary for strength and rigidity.

10.0 GLAZING



10.1 General

Glazing shall be done with plain, frosted, ground glass or wired cast glass, laminated safety glass or toughened glass etc. as shown on drawings, described in the Schedule of Items or approved by the Engineer. The method of glazing adopted shall be such that movement of the structure, to which the securing is done, does not transmit strain to windows, doors or ventilators as the case may be. The work shall generally conform to IS:1081-1960 "Code of Practice for Fixing and Glazing of Metal Doors, Windows & Ventilators". The material for putty shall consist of whiting and linseed oil, raw-mixed in such proportion as to form a paste conforming to IS : 419-1967.

10.2 Doors, Windows and Ventilators

Windows and ventilators shall be designed for putty glazing fixed from outside and glazed doors for fixing from inside. In addition, spring type glazing clips shall be provided at intervals of 30 cm, or as shown otherwise on drawings or described in the Schedule of Items. These shall be inserted into holes drilled in the shutters or frames as the case may be.

All glazing shall be puttied to the shutters of frames with good quality putty in addition to glazing clips. Glass panes shall not be placed

	LAYING, INSTALLATION, TESTING AND COMMISSIONING OF 8” DIA. STEEL GAS PIPELINE CONNECTIVITY IN PATAN GA	
TENDER DOCUMENT NO REPL/SGL/STPL/009/22		Date: -28/11/2022

directly against the metal/timber. A thin layer of putty shall be even spread over the glazing rebate and the glass pressed firmly against it. It shall be secured in position by means of teak wood beads for wooden shutters. Glass panes shall be set without springing & shall be bedded in putty and back puttied, except where moulding or gasket are specified. Putty etc. shall be smoothly finished to even lines. Figured glass shall be set with smooth side out. After completion of glazing work, all dirt stains, excess putty etc., shall be removed and the glass panes shall be left in perfectly acceptable condition. All broken cracked or damaged glass shall be replaced by new ones at the Contractor's cost.

10.3 Northlight Glazing

This shall consist of aluminium or steel glazing bars as shown on drawings or described in the Schedule of Item and be subject to approval of Engineer. The glazing parts shall be securely fixed in their frame and shall be weather-proof. All glazing shall be flashed to the surrounding so as to be weather-proof. Glass shall be fixed to the astragals with glazing clips and putty.

11.0 WHITE WASHING, COLOUR WASHING AND PAINTING

11.1 Scope



This chapter deals with white washing, colour washing, distempering, cement washing, emulsion painting, silicate painting etc., to concrete and masonry surfaces and painting to the wood works and steel works. For the items which have not been completed or partly covered in this chapter, specifications suggested by the manufacturers for the materials, surfaces preparation, workmanship and all bye works shall be strictly followed and shall be carried out as per direction of the Engineer.

11.2 Materials

Materials shall conform to Part - I

11.3 White Washing, Colour Washing

11.3.1 General

	LAYING, INSTALLATION, TESTING AND COMMISSIONING OF 8" DIA. STEEL GAS PIPELINE CONNECTIVITY IN PATAN GA	
TENDER DOCUMENT NO REPL/SGL/STPL/009/22		Date: -28/11/2022

Wherever scaffolding is required/necessary, it shall be erected on double support tied together by horizontal pieces, over which the scaffolding planks shall be fixed. No part of it shall rest on or touch the surface which is being washed/painted. Where ladders are used, pieces of old gunny bags shall be tied on their tops to avoid damage or scratches to walls. For white washing the ceiling, proper stage scaffolding shall be erected. The surface on which wash is to be applied shall be thoroughly brushed free from mortar droppings and foreign matter.

11.3.2 White Wash

The wash shall be prepared from fresh stone white lime of approved quality and shall be thoroughly slaked on the spot mixed and stirred with sufficient water to make a thin cream. This shall be allowed to stand for 24 hours and then shall be screened through a clean coarse cloth. 4 Kg of gum dissolved in hot water shall be added to each cubic metre of the cream.



The approximate quantity of water to be added in making the cream will be 5 litres of water to 1 Kg of lime. Indigo/ultramarine blue upto 3 gm per kg of lime dissolved in water shall then be added and wash stirred well. Water shall then be added at the rate of about 6 litres per kg of lime to produce a milky solution. The white wash shall be applied with approved brushes to the specified number of coats. The operation for each coat shall consist of stroke of brush given from the top downwards, another from the bottom upwards over the first stroke and similarly one stroke horizontally from the right and another from the left before it dries. The white washing on ceiling shall be done prior to that on walls.

Each coat shall be allowed to dry before the next one is applied and shall be subjected to inspection and approval by the Engineer. No portion of the surface shall be left out initially to be patched up later on.

The finished dry surface shall not show any signs of cracking and peeling nor shall it come off readily on the hand when rubbed. Doors, windows, floors and such other parts of the building not to be white washed shall be protected from being splashed upon.

11.3.3 Colour Wash

A priming coat of white wash with lime shall be applied before applying

	LAYING, INSTALLATION, TESTING AND COMMISSIONING OF 8” DIA. STEEL GAS PIPELINE CONNECTIVITY IN PATAN GA	
TENDER DOCUMENT NO REPL/SGL/STPL/009/22		Date: -28/11/2022

two or more coats of the colour wash (as specified). Entire surface should represent a smooth and uniform finish. Sample of colour wash shall be duly approved by the Engineer before application. Same specification as that of white wash shall be followed for colour wash also using necessary amount of colouring ingredient of approved tint.

11.3.4 White Washing with Whiting



Whiting (ground white chalk) shall be dissolved in sufficient quantity of warm water and thoroughly stirred to form a thin slurry which shall then be screened through a clean coarse cloth. 2 Kg of gum and 0.4 Kg of copper sulphate dissolved separately in hot water shall be added for every cum. of slurry which shall then be diluted with water to the consistency of milk so as to make wash ready for use. Other specification remains same as per white washing with lime.

11.4 Cement Primer Coat

The surface shall be thoroughly cleaned of dust, mortar, droppings etc., and shall be allowed to dry for at least 48 hours. It shall then be rubbed thoroughly be sand paper to give a smooth and even surface. Any unevenness shall be made good by applying putty, made of plaster of paris mixed with water on the entire surface including filling up the undulation and then sand papering the same after it is dry. The cement primer shall preferably be applied by brushing and not by spraying. Horizontal strokes shall be given first and vertical strokes shall be applied immediately, afterwards. This entire operation will constitute one coat. The surface shall be finished as smooth as possible, leaving no brush marks.

11.5 Water-proof cement paint

The prepared surface shall be thoroughly wetted with clean water before water proof cement paint is applied. The paint shall be prepared strictly as per manufacturer's specifications, in the absence of which it shall be mixed in two stages. The first stage shall comprise of 2 parts of water proof cement paint and one part of water stirred thoroughly and allowed to stand for 5 minutes. Care shall be taken to add the paint gradually to the water and not vice versa. The second stage shall comprise of adding further one part of water to the mix and stirring thoroughly to obtain a liquid of workable and uniform consistency. The paint shall be mixed in such quantities as can be used up within an hour of its mixing.

	LAYING, INSTALLATION, TESTING AND COMMISSIONING OF 8” DIA. STEEL GAS PIPELINE CONNECTIVITY IN PATAN GA	
TENDER DOCUMENT NO REPL/SGL/STPL/009/22		Date: -28/11/2022



Paint shall be applied with brushes or spraying machine. The solution shall be kept well stirred during the period of application. It shall be applied as far as possible on the surface which is on the shady side of the building so that direct heat of the sun on the surface is avoided. Painted surfaces shall be sprinkled with water 2 or 3 times a day. This shall be done between coats and for at least 2 days following the final coat. The curing shall be started as soon as paint has hardened so as not to damage by sprinkling of water say about 12 hours after the application. A uniform shade should be obtained after application of paint. Cement paint shall not be applied on surfaces already treated with white wash, colour wash, distemper, varnish paint etc., and on gypsum, wood and metal surfaces.

11.6 Synthetic washable distemper

The surface shall be prepared as for Cement Primer Coat. A primer coat of cement or distemper primer shall be applied as specified in the description of the item. Unevenness in the plaster shall be made good by applying plaster of Paris putty mixed with distemper of the colour to be used on the entire surface including filling up the undulations. The surface shall then be rubbed down with a fine grade sand paper and made smooth. After the primer coat has dried for at least 48 hours, the surface shall be lightly sand papered to make it smooth, taking care not to rub the priming coat out. All loose particles shall be dusted off. One coat of distemper properly diluted with thinner, shall be applied with brushes/rollers in horizontal strokes followed immediately by vertical ones which together constitute one coat. The subsequent coats shall be applied in the same way. Two or more coats of distemper as are found necessary shall be applied to obtain an even shade. A time interval of at least 24 hours shall be allowed between consecutive coats. The brushes shall be of 15 cm. double bristled type. They shall be maintained in proper condition and those that are dirty or caked will not be allowed to be used. The finished surface shall be even and uniform without patches, brush marks, distemper drops etc. Sufficient quantity of distemper shall be mixed to finish one room for applying one coat in one operation.

11.7 Dry Distemper

The surface shall be prepared in the same manner as for synthetic washable distemper. A primer coat using approved whiting shall be applied over the prepared surface. Distemper prepared as per manufacturer's direction shall be applied and each coat shall be

	LAYING, INSTALLATION, TESTING AND COMMISSIONING OF 8” DIA. STEEL GAS PIPELINE CONNECTIVITY IN PATAN GA	
TENDER DOCUMENT NO REPL/SGL/STPL/009/22		Date: -28/11/2022

allowed to dry before subsequent coat is applied. The finished surface shall be free from chalking when rubbed, even, uniform and shall show no brush marks.

11.8 Plastic emulsion paint

The surface on which plastic paint has to be laid must be thoroughly cleaned and prepared and all defects rectified and finally prepared in the same manner as for synthetic washable distemper. The surface shall be dry and rubbed smooth by means of sand paper to the satisfaction of the Engineer. One coat primer and two coats of plastic emulsion paint are to be applied. The work is to be carried out under direct guidance and instructions from the manufacturers whose expert advice and supervision are to be made available in order to achieve the high grade finish. The painters employed for this work must be capable of producing the highest standard of workmanship required. If the finish is of doubtful nature, the contractor shall have to rectify at his own cost to the entire satisfaction of the Engineer.

11.9 Bitumen painting

Bitumen painting to concrete surface shall be done as follows :



(i) Hot application

The surface shall be cleaned of all mud etc., before painting. The honey-combs and other defects of concrete surfaces to be painted shall be rectified properly. Any projection of binding wire shall be cut to keep it 10 mm inside the concrete surface and then filled with mortar. Before application the surface shall be absolute dry.

Bitumen of standard quality as specified shall be heated to the temperature specified by the maker and then applied hot with brushes on the prepared surface. The surface shall be allowed to cool before applying the second coat.

(ii) Cold application

The surface shall be prepared in the same way as for hot application. The bitumen emulsion of approved quality shall be applied with special brushes. Where acid resistant treatment is specified such surface shall be covered with approved acid resisting coating to the satisfaction of the

	LAYING, INSTALLATION, TESTING AND COMMISSIONING OF 8" DIA. STEEL GAS PIPELINE CONNECTIVITY IN PATAN GA	
TENDER DOCUMENT NO REPL/SGL/STPL/009/22		Date: -28/11/2022

Engineer. Before the coating is applied, the surface shall be properly cleaned and prepared in the manner described above.

11.10 Tarring

- (i) Timber surfaces in contact with earth/concrete/ plaster shall be treated with one coat of hot tar or as specified in schedule before fixing.
- (ii) If required steel work in holdfasts and the like shall be treated as above and sanded in addition before being fixed in position.

11.11 Painting to Timber & Steel Surface

11.11.1 General

The priming coat for steel/wood work shall be applied after the surface has been prepared. After the priming coat has dried, all nails, screw holes and cracks shall be filled with putty and surface smoothed with sand paper.



All surfaces must be thoroughly dry before painting work is started and painting in exterior/exposed parts shall not be taken up in wet/humid or otherwise unfavourable weather.

All stains of paint to glasses, walls, fittings and fixtures etc. shall be cleaned thoroughly by applying required turpentine or thinner. The contractor's rate shall include all these.

11.11.2 Painting to timber

- (i) Unless otherwise specified, all timber surfaces shall be treated with one priming coat, one under coat and one finishing coat. Under coat and finishing coat shall be synthetic enamel or as specified. Priming coat shall be of approved primer. In case the surface is to be polished or varnished, a priming coat as approved or specified shall be given. No primer shall be applied to wood work until it has been inspected and passed by the Engineer.

- (ii) **Polishing**

	LAYING, INSTALLATION, TESTING AND COMMISSIONING OF 8" DIA. STEEL GAS PIPELINE CONNECTIVITY IN PATAN GA	
TENDER DOCUMENT NO REPL/SGL/STPL/009/22		Date: -28/11/2022

The surface to be polished shall be prepared in the same manner as specified under painting.

(iii) French Spirit Polish

After preparation of the surface it will be well dusted and then the pores of the wood shall be filled up with a filler made of a paste of whiting in water or methylated spirit with a pigment if so required. The spirit polish shall be prepared by dissolving pure shellac in methylated spirit, @ 0.75 Kg of shellac to 5 litres of spirit, with the addition of pigment if so required.

The polish shall be applied with a pad consisting of cotton wool inside a clean white cloth. Several coats shall be applied with light sand papering from time to time and cleaning the dust before applying next coat except the final coat. The final coat of the polish shall be rubbed thoroughly until the wood feels perfectly dry when touched and gives a satisfactory smooth shining.

(iv) Wax Polishing

After preparation of surface wax polish will be applied. The polish shall be prepared by heating together 2 parts of pure bees wax and boiled linseed oil each over a slow fire. When the wax is completely dissolved the mixture shall be cooled till it is just warm and one part of genuine turpentine is to be added and entire mixture shall be well stirred.

Polish shall be applied in the same manner as specified for spirit polish.



11.11.3 Painting to Steel Surface

11.11.3.1 General

All surfaces shall be thoroughly cleaned of all dirt, grease, rust and mill scale. Areas which become inaccessible after assembly shall be painted before assembly after cleaning the surfaces as described above. The surfaces shall be perfectly dry before painting.

Wherever shop primer painting is damaged, the surfaces shall be thoroughly cleaned and touched up with corresponding primer.

Site painting shall not be done in frosty or foggy weather or when humidity is such as to cause condensation on the surface to be painted.

	LAYING, INSTALLATION, TESTING AND COMMISSIONING OF 8” DIA. STEEL GAS PIPELINE CONNECTIVITY IN PATAN GA	
TENDER DOCUMENT NO REPL/SGL/STPL/009/22		Date: -28/11/2022

11.11.3.2 Steel Structures

Unless otherwise specified all structures shall be painted with two coats of primer. One coat shall be applied at shop and the second coat at site. All structures after erection shall be given two coats of finishing paint and shall be of synthetic enamel of approved colour. The under coat shall have different tint to distinguish from the finishing coat.

11.11.3.3 Galvanized Iron Sheets

All plain and CGI sheets requires surface pre-treatment or use of other patented primer to ensure adhesion of paint to zinc coated surfaces. Such pre-treatment shall be as per manufacturer's specifications. Where pre-treatment is adopted one coat of primer paint of suitable quality shall be applied. Unless otherwise specified the finishing coats shall consist of an under-coat of an aluminium paint having blue tint and a second coat of aluminium paint having aluminium colour.

11.11.3.4 Structures embedded

Exposed surfaces of embedded parts shall be given two coats of red lead graphite primer at shop and finished with two coats of anti-corrosive paint at site after embedment. Type of paint and procedure of painting shall be as per manufacturer's specification. Surfaces to be field welded shall have no paint applied within 100 mm of the welding zone.



12.0 INTERNAL WATER SUPPLY PLUMBING, DRAINAGE & SANITATION

12.1 Scope of Work

The work comprises supply, laying testing, commissioning etc. of water supply, plumbing, drainage & sanitation.

The work includes the following activities connected with the job :

- i) Supply and delivery of all required pipes and other materials.
- ii) Earthwork in excavation for trenches, pits/chambers/manholes etc.

	LAYING, INSTALLATION, TESTING AND COMMISSIONING OF 8” DIA. STEEL GAS PIPELINE CONNECTIVITY IN PATAN GA	
TENDER DOCUMENT NO REPL/SGL/STPL/009/22		Date: -28/11/2022

- iii) Civil works connected with the laying/erection of pipe lines such as making holes in the wall etc. and repairing them after pipe erection, construction of pipe supports, valve chambers, manholes, bedding and covering of pipe laying wherever required.
- iv) Laying and jointing of pipe lines as specified in this chapter
- v) Testing of pipe lines after laying as per standard tests specified in this chapter.
- vi) Back filling of trenches after successful and satisfactory testing.
- vii) Disinfection of the complete piping system in the case of water supply.
- viii) Commissioning of entire network.
- ix) Safe custody of the pipes/materials/equipment/work and other obligation stated elsewhere in the specification.
- x) Any other activities which are not mentioned above but essential and required.

12.1.1 Materials



The materials shall conform to Part-I of this series.

12.2 Water Supply & Plumbing

12.2.1 General

12.2.1.1 General Requirements

The Contractor shall lay all the pipes and fittings in the best workman like manner by skilled workmen and licensed plumbers in conformity with the regulations and requirements of the local appropriate authorities and to the satisfaction of the Engineer. Unless otherwise specified water supply works in buildings shall be carried out in accordance with IS:2065-1983 "Code of Practice for Water Supply in Buildings" & IS:2064-1993 "Code of practice for selection, installation and maintenance of sanitary appliances".

	LAYING, INSTALLATION, TESTING AND COMMISSIONING OF 8" DIA. STEEL GAS PIPELINE CONNECTIVITY IN PATAN GA	
TENDER DOCUMENT NO REPL/SGL/STPL/009/22		Date: -28/11/2022

12.2.2 Installation

All works like earth work, masonry, concrete, steel work, cutting holes, chases in brick, concrete & RCC works, cutting of roads, repairs and rectifications associated directly with the installation of water supply system shall come under the scope of the contractor and shall be governed by the specification of the relevant chapter.

12.2.3 Laying

Before lowering down for laying in the trenches, the pipes shall be checked against crack by means of light hammering and for any other damage. All fixing shall be carefully aligned and spaced at a distance from the main structure to give reasonable all round access for maintenance and inspection and laid true to line plumb and level. Any deviation shall need approval of the Engineer. Meticulous care shall be taken to avoid chances of airlock and water hammer.

Pipes shall be laid on continuous unyielding surface holder or on reliable supports at least one near each joint and spacings as directed by the Engineer. The support must be strong, neat and shall have provisions for securing the pipes in every direction and easy maintenance. If situation requires, pipes shall be encased or concealed in masonry or concrete if shown on drawing or directed by the Engineer. Pipes embedded in floors and wall shall be securely bound so as not to allow any movement due to expansion and contraction. adequate width shall be provided to lay the pipes as per standard practice.



Excavation below the required level is not permitted. The contractor shall make good any excess excavation as directed by the Engineer.

Soft spots in the bottom of beds for pipe lines in rock shall be leveled with sand or soft soil or concrete as approved by the Engineer and the thickness of the layer shall not be less than 100mm.

12.2.4 Excavation for pipe lines in trenches

Excavation shall comply with chapter 2. The sides of pits and trenches shall be adequately supported at all times, except where otherwise directed by the Engineer.

12.2.5 Underground piping in and around building

	LAYING, INSTALLATION, TESTING AND COMMISSIONING OF 8" DIA. STEEL GAS PIPELINE CONNECTIVITY IN PATAN GA	
TENDER DOCUMENT NO REPL/SGL/STPL/009/22		Date: -28/11/2022

Underground piping shall be laid at such a depth that it is not likely to be damaged by traffic and other loads and frost, where applicable, and as shown in the drawing and instructed by the Engineer. The thrust blocks shall be provided wherever required.

The size and depth of the trench shall be as approved by the Engineer. Backfilling in trenches shall be done with selected fine earth, unless otherwise permitted, in 150mm layers and carefully consolidated and well treated so that it does not set as a drainage channel. Special care shall be taken while filling in the vicinity of the pipe to avoid damages. Before backfilling the laid pipe shall be fully tested and approved.

12.2.6 Concealed piping



Where desired by the Engineer or shown on the drawings the pipes shall be concealed in masonry or concrete of the adjoining structure by making chases in walls/floors and these shall be secured by hooks and the chases filled with concrete 1:2:4 (1 cement, 2 sand and 4 aggregate). The contractor will rectify, if required the chases, openings and pipes, supplement and make good after laying and testing of the concealed pipelines.

12.2.7 GI.Piping

12.2.7.1 The pipes shall be fixed in longest lengths possible with all necessary bends, tees, couplings, reducing ockets, short piece, jamnut and tees etc. in perfect straight lines both vertically and horizontally.

12.2.7.2 All exposed GI pipes shall be fixed at least 15mm clear of wall face with holder bat clamps at suitable places not exceeding (2.5 metres) centre to centre. Where the pipes are laid in chases in walls as shown in the drawing, these shall be secured to walls by hooks. Chases in walls and floors shall be filled in with cement concrete 1:2:4. Where the pipes are to be run underground these may be laid at least 60 cm below ground level.

12.2.7.3 The joints of pipes and fittings shall be sealed with red lead paint and fine spun yarn. Joints must be perfectly water tight when put under maximum test pressure.

	LAYING, INSTALLATION, TESTING AND COMMISSIONING OF 8” DIA. STEEL GAS PIPELINE CONNECTIVITY IN PATAN GA	
TENDER DOCUMENT NO REPL/SGL/STPL/009/22		Date: -28/11/2022

12.2.7.4 Unless otherwise specified the exposed portion of pipes and fittings shall be given two coats of approved synthetic enamel paint over a coat of approved priming. Pipes laid underground or concealed in walls/floors shall be treated with two coats of bituminous paint.

12.2.8 Jointing of pipes

The interior of all pipes and joints shall be cleaned before jointing commences. Jointing of pipes shall be done in such a manner as to render them completely leakproof and durable. Instruction of the manufacturer shall be followed unless desired otherwise by the Engineer. However, the general norms and recommended practices for different types of pipes are given below for guidance:

(a) Cast Iron

i) Spigot and socket joints :

Interior surface of bells and exterior surface of smooth ends of pipes shall be cleared of redundant insulating cover and other foreign materials particularly of oil, burning off materials from bells and smooth pipe ends. Sharp rises on interior bell surface shall be smoothed out.

Bells should be lined up, in compliance with direction of pipe. Laying work shall be started from lower points.



ii) Lead and Flanged Joint :

Lead joints shall be made as per Sl. 15.4.6.1 and flanged joints as per Sl. 15.4.6.2 of chapter 15.

b) Steel Pipes

Plain ended steel pipes may be jointed by welding. Screwed and socketed joints shall be carefully tightened. Care shall be taken to remove burring from the ends of the pipes. Jointing compound, if used, shall be lead free and approved by the Engineer.

c) G.I Pipes

	LAYING, INSTALLATION, TESTING AND COMMISSIONING OF 8" DIA. STEEL GAS PIPELINE CONNECTIVITY IN PATAN GA	
TENDER DOCUMENT NO REPL/SGL/STPL/009/22		Date: -28/11/2022

Threads shall be cut with, sharp tools, and before jointing all scale shall be removed from pipes by suitable means. The screw threads of the pipe shall be cleaned out and the joint made by screwing the fitting after treating the threads with approved pipe jointing compound. Once a joint has been screwed up it shall not be backed off unless threads are recleaned and new compound applied.

d) Asbestos cement pipes



Socket and spigot ended pipes shall be jointed by caulking with tarred gaskets and grouted with 1:3 cement sand mortar.

12.2.9 Precautions

- a) All water supply pipes shall be so laid and so fixed and maintained as to be and remain completely water tight.
- b) During installation open ends of each pipe shall be protected by suitable covers or plugs so that the ends, thread, sockets or spigot are not damaged and no foreign materials can make its way into the pipe line.
- c) Due care should be taken to ensure that there shall be no cross connection whatsoever between a pipe or fitting for conveying or containing wholesome water and a pipe or fitting containing impure water or water liable to contamination or of an uncertain quality of water which has been used for any other purposes.
- d) Fittings and fixtures liable to be stolen shall be fitted and fixed just before testing and handing over.

12.2.10 Painting

When mentioned in the schedule of item underground steel and cast iron pipes shall be treated with 2 coats of anticorrosive bituminous paint on the outside surface after cleaning the surface from soil, dust, moisture, rust, scales soot etc. When painting is to be done for pipes above ground, G.I. pipes shall be given a coat of zinc chromate primer, C.I. & M.S. pipes shall be given one coat of red lead or zinc chromate primer over which at least 2 coats of paint of best quality and manufacture as approved by the Engineer shall be provided or as

	LAYING, INSTALLATION, TESTING AND COMMISSIONING OF 8” DIA. STEEL GAS PIPELINE CONNECTIVITY IN PATAN GA	
TENDER DOCUMENT NO REPL/SGL/STPL/009/22		Date: -28/11/2022

specified in the schedule of item.

12.2.11 Ferrule and stop cock box with chamber

Square cast iron surface box 15 cm square and 22.5 cm deep weighing not less than 4.54 Kg with hinged lid shall be provided in masonry chamber. Top of box shall be made flush with the finished level of the chamber. The chamber 25cm x 25cm inside shall be with half brick wall in cement mortar 1:4 over a cement bed concrete of 75mm thick in proportion 1:4:8 with stone chips. The inside wall faces shall be plastered with 12mm thick cement mortar 1:4 finished smooth with a floating coat of neat cement.

The exposed surfaces of cast iron box and cover shall be treated with two coats of bituminous paint.

12.2.12 Inspection, Testing and Acceptance

12.2.12.1 Pipes, fittings and fixtures before laying



All pipes, fittings and appliances shall be inspected, before delivery at the site to see whether they conform to accepted standards. The pipes and fittings shall be

inspected on site before laying and shall be sounded to disclose cracks. Any defective items shall be clearly marked as rejected and forthwith removed from the site.

12.2.12.2 Testing of pipes after laying

General

- a) The contractor shall ensure the safety of the pipe work under test and provide all necessary stoppers, testing apparatus etc. that are required for testing.
- b) The contractor shall be responsible for any damage done to pipe work and ancillary work while testing and shall replace any pipe

	LAYING, INSTALLATION, TESTING AND COMMISSIONING OF 8" DIA. STEEL GAS PIPELINE CONNECTIVITY IN PATAN GA	
TENDER DOCUMENT NO REPL/SGL/STPL/009/22		Date: -28/11/2022

or fitting which does not satisfactorily withstand the test.

- c) The contractor shall give written notice of the times at which tests are to take place. On completion of each test two copies of the complete records shall be given to the Engineer.
- d) The work will not be considered complete until the tests are found satisfactory and a certificate issued by the Engineer.

After laying and jointing, the main shall be slowly and carefully charged with water, so that all air is expelled from the main by providing a 25mm inlet with a stop-cock, allowed to stand full of water for a few days if time permits and then tested under pressure. The test pressure shall be 6Kg/cm² or double the maximum working pressure, whichever is greater. The pressure shall be applied by means of a manually operated test pump, or in the case of long mains or a large diameter, by a power driven test pump, provided that pump is not left unattended. In either case due precaution shall be taken to ensure that the required test pressure is not exceeded. Pressure gauges shall be accurate and shall preferably have been re-calibrated before the test. The pump having been stopped, the test pressure shall maintain itself without measurable loss for at least five minutes. The end of the main shall be closed by fitting a water-tight expanding plug and the plug shall be secured by struts to resist the end thrust of the water pressure in the mains.



12.2.12.3 Testing of service pipes and fittings

The service pipes shall be slowly and carefully charged with water allowing all air to escape avoiding all shock or water hammer. The service pipe shall then be inspected under working conditions of pressure and flow. When all draw-off taps are closed, the service pipes shall be absolutely watertight. All pipings, fittings and appliance shall be checked for satisfactory support and protection from damage, corrosion and frost.

12.2.13 Storage Tank

12.2.13.1 Pressed steel tank

Pressed steel water storage tanks shall be of nominal size and capacity as mentioned in the Schedule of Item and fabricated with all flanges

	LAYING, INSTALLATION, TESTING AND COMMISSIONING OF 8” DIA. STEEL GAS PIPELINE CONNECTIVITY IN PATAN GA	
TENDER DOCUMENT NO REPL/SGL/STPL/009/22		Date: -28/11/2022

external / internal or bottom flange internal and side flanges external, as shown on drawings or schedule of items. Inlet, overflow, vent pipes and manholes shall be arranged and provided as shown in drawing or mentioned in the schedule. Unless otherwise specified, the outlet pipe shall be 50mm above the bottom of the tank and there shall be 150mm free board at the top of the tank. The fabricator shall supply 5 prints of fabrication drawing to the Engineer for prior approval showing thickness of plates, method of jointing the plates. All supports, stays, gussets etc. Pads, cleats etc., required for supporting the tanks shall also be supplied by the manufacturer.



All tanks shall be supplied with mosquito-proof top with manhole not less than 450mm diameter. Tanks deeper than 1.00 Metre shall be provided with M.S. internal access ladder adjacent to the manhole. Meter level indicator shall be provided if asked for. Two coats of anticorrosive paint over a suitable primer shall be applied to both internal a external surface of tanks. The paint shall be so selected as not to impart any taste or odour of water and be of lead free composition.

12.2.13.2 G.I. Water Tank

G.I. water tanks shall be procured from a reputed manufacturer. The design shall be good enough to withstand the loads safely. Galvanized iron water storage tank shall be made of minimum 16 gauge galvanized iron sheet. Unless otherwise specified plain sheets shall be fixed at the corner to angle iron frames by means of 6 mm rivets at 40 mm pitch for tanks upto 1000 litres capacity and 8 mm rivets at 35 mm pitch for tanks above 1000 litres capacity. Tanks above 1000 litres shall have 20 mm dia. galvanised iron stays, one fixed to angle framing at top and two in the body of the tank for extra strength. Holes for rivetting shall be drilled and not punched. Lead shall be applied to the joints before rivetting.

Tanks shall have 400 mm dia. holes at the top with hinged covers. The covers shall be made of galvanised iron sheet with angle iron frame. The cover shall be just loose but close fitting to keep out dust and mosquito and will not be airtight. It shall be complete with lockable arrangement.

Tanks unless otherwise specified shall be provided with rising main inlets of 40 mm dia. galvanised iron pipe or as shown on drawing and 40 mm dia. G.I. overflow pipe and 25 mm washout with plug. If

	LAYING, INSTALLATION, TESTING AND COMMISSIONING OF 8" DIA. STEEL GAS PIPELINE CONNECTIVITY IN PATAN GA	
TENDER DOCUMENT NO REPL/SGL/STPL/009/22		Date: -28/11/2022

specified the rising main shall be connected to the tank with a ball valve near the top which disconnects the supply when tank is full up to the point of overflowing.

The ball valve shall permit the entry of water when the tank is empty and disconnect the supply when the tank is full. It consists of a hollow floating ball made of copper, plastic or hard rubber, 110 mm in diameter attached to an arm which is so pivoted that the end near the pivot close the orifice of the main when the ball is raised to the required height of water in the tank and opens the main as soon as the ball drops with the fall of water level as it is drawn off through the distribution. The ball valve shall be fixed to the tank in such a position that the body of the ball valve submerge when the tank is full upto the water line. The ball valve shall be so adjusted as to limit the level of the water in the tank below the lip of the over-flow pipe, and above the maximum water filled level shall be as per the standard norms for GI water tank.

12.2.13.3 Water reservoirs made of concrete or masonry shall be governed by the specification in the relevant chapter. It shall have, inlet, outlet, overflow and wash out with plug and a top MS/CI cover as per schedule of items and drawings.

12.3 Drainage and Sanitation (Internal)



12.3.1 Scope

This section covers the layout and construction of drains for waste water, surface water and sewage together with all fittings and fixtures inclusive of ancillary works, such as connectins, manholes and inspection chambers used within and around the building and the connection to a public sewer upto treatment work, septic tank and soak pit. All sewerage and drainage works shall be executed in accordance with specifications given for different works. All sewerage and drainage works shall be executed by a licensed plumbing supervisor or a licensed plumber and in accordance with IS : 1742-

1983 "Code of Practice for Building Drainage" unless otherwise specified.

12.3.1.1 Installation

All pipe lines, locations of fittings and fixtures, etc. shall be as per

	LAYING, INSTALLATION, TESTING AND COMMISSIONING OF 8" DIA. STEEL GAS PIPELINE CONNECTIVITY IN PATAN GA	
TENDER DOCUMENT NO REPL/SGL/STPL/009/22		Date: -28/11/2022

drawings or as directed by the Engineer. Correctness of lines, plumbs, orientation, symmetry and levels shall be strictly ensured. All items shall be fully secured against movement in any direction and shall be located so as to allow easy maintenance.

All pipelines, fittings and fixtures shall be installed leakproof; when the works under scope of this specification are linked up with works executed by others, the connections shall be such as to prevent any splashing or spilling or emission of foul odour and gasses.



12.3.2 Rainwater Downcomers

Rainwater downcomers shall be standard cast iron or asbestos cement pipes. In case where specifically desired, M.S. pipes may also be used. M.S. pipes shall be painted outside with two coats of anticorrosive paint over a coat of primer. Rain water downcomers shall run along and be secured to walls columns, etc. Where desired by the Engineer these may have to be installed in chases cut in the structure. All pipes shall be well secured and supported by adequately strong brackets. The brackets may be wrought iron clamp type, split ring type or perforated strap iron type as approved by the Engineer. For vertical runs each pipe shall hang freely on its brackets fixed just below the socket. Suitable spacer blocks shall be provided against the vertical surface to which the pipe is fixed. Roof and floor drains and yard gullies shall be installed, if required, by cutting into the structure and grouted with 1:2:4 cement concrete. All gutters shall be provided with removable gratings. All horizontal pipes shall have a minimum fall of 1 in 100.

12.3.3 Gutter

The gutters shall be made of G.I. or A.C. Gutters shall be supplied by reputed specialised firms. Each section shall be sufficiently rigid, edges and corners straight and the slopes perfectly uniform. GI gutters shall have the edges strengthened by suitable means. The joints may be made by rivetting, bolting or soldering.

Unless specified otherwise the gutters shall have a minimum fall of 1 in 120. Adequate number of string supports shall be provided so that there is no deflection even when the gutter is full. Each joint must have a support. Unless otherwise specified the supports shall be fabricated of MS brackets. All junctions shall be thoroughly watertight. The joints may be made by rivetting, bolting or soldering. All joints between

	LAYING, INSTALLATION, TESTING AND COMMISSIONING OF 8" DIA. STEEL GAS PIPELINE CONNECTIVITY IN PATAN GA	
TENDER DOCUMENT NO REPL/SGL/STPL/009/22		Date: -28/11/2022

successive lengths of gutters shall have an overlap of at least 5 cm. The drop in the overlap shall always be in the direction of the fall of the gutter. Ends of gutters shall be closed watertight. Junction with rainwater downcomers shall be made fully watertight and secured.

12.3.4 Soil and Drainage Pipes

12.3.4.1 Gradients

If not specified the minimum gradients of soil and drainage pipe line shall be as follows :

- 100 mm nominal dia : 1 in 35
- 150 mm nominal dia : 1 in 65
- 230 mm nominal dia : 1 in 120
- 300 mm nominal dia : 1 in 200

12.3.4.2 Relation with water supply pipe lines

Unless specifically cleared by the Engineer, under no circumstances shall drainage and soil pipes be allowed to come close to water supply pipelines.



12.3.4.3 Laying

Each separate pipe shall be individually set for lines and levels. Where lengths of sewer or drain pipes are laid in trench, properly painted sight rails shall be fixed across the trench at a height, equal to length of the boning rod to be used, above the required invert level of the drain or sewer at the point where the sight is fixed. More sight rails shall be required at manholes, change of gradient and intermediate positions if the distance for sighting is more than 16 m apart. The excavation shall be boned in at least one in every 2 m. The foot of the boning rod shall be set on a block of wood of the exact thickness of the wall of the pipe.

Each pipe shall be separately and accurately boned between sight rails.

12.3.4.4 Support and protection on pipelines

All pipes shall be laid with sockets leading uphill. Preferably the pipe

	LAYING, INSTALLATION, TESTING AND COMMISSIONING OF 8" DIA. STEEL GAS PIPELINE CONNECTIVITY IN PATAN GA	
TENDER DOCUMENT NO REPL/SGL/STPL/009/22		Date: -28/11/2022

shall rest on solid and even foundations for the full length of the barrel. However, the pipe manufacturer's instruction as approved by the Engineer shall be followed in the matter of support and jointings.



Where pipes are not bedded on concrete, the bed shall be left slightly high and carefully placed so that the pipe barrels rest on undisturbed ground. If anywhere the excavation has been carried too low packing shall be done in concrete. Where laid on rock or very hard ground which cannot be easily excavated to a smooth surface, the pipes shall be laid on a cradle of sand or gravel as desired by the Engineer. PVC or similar pipes shall be laid directly on stable soil and packed with selected soil.

The minimum support and protection for glazed stoneware pipes shall be as follows :

- a) When cover is less than 1 metre and where pipes are unavoidably exposed above ground surface, the pipes shall be completely encased surrounded with concrete as per IS:4127-1983.
- b) Where pipes are laid on soft soil with the maximum water table laying at the invert of the pipes, the sewer shall be bedded on concrete 1:4:8 mm with 20mm down aggregates as per IS:4127-1983.
- c) Where the pipes have to be laid on soft soil with the maximum water table rising above the invert of the pipe, but below the top of the barrel, the pipe sewer shall be haunched with concrete 1:4:8 mm with 20mm down aggregates as per IS:4127-1983.
- d) Where maximum water table is likely to rise above the top of the barrel the pipe sewers shall be completely encased/surrounded with 1:4:8 concrete with 20mm down aggregate as per IS:4127-1983.

Vitrified clay pipes shall be laid on a bed of 150mm thick cement concrete (1:3:6) nominal mix by volume.

Cast iron pipes and concrete pipes may be supported on suitable concrete or brick support, where specified. The support shall be unyielding and strong enough. At least one support shall be located close to ends. Spacing of intermediate supports shall be as decided by

	LAYING, INSTALLATION, TESTING AND COMMISSIONING OF 8" DIA. STEEL GAS PIPELINE CONNECTIVITY IN PATAN GA	
TENDER DOCUMENT NO REPL/SGL/STPL/009/22		Date: -28/11/2022

the Engineer. Pipes shall be secured to the supports by approved means.

Anchoring of pipes where necessary shall be achieved by suitable concrete encasing designed for the expected thrust.

12.3.4.5 Entry into structures

For entry of the pipes lines into any building or structure suitable conduits under the structure or sleeves shall be used. The conduits and sleeves shall be such as to allow easy repairs and replacement of the pipes. Where openings or chases are required to be made in the structure for entry of pipe lines, locations and sizes shall be marked and checked by the Engineer. After laying of the pipeline, the openings and chases shall be mended.



12.3.4.6 Traps and Ventilating pipes

- a) Pipes carrying the sewage from water closets and waste water and overflow water from baths, wash basins, sinks shall be trapped immediately beneath such fixtures. Traps shall have minimum water seal of 50mm and shall be ventilated whenever such ventilation is necessary to maintain water seal of the trap. Ventilating pipes shall be carried up vertically from the drain to a height of at least 600mm above the outer covering of the roof top of the building or as shown on drawings. All vertical ventilating, anti-siphonage and similar pipe shall be covered on top with a cowl. The cowl shall be made of C.I. unless desired otherwise by the Engineer.

Connecting to existing sewer lines shall be through a manhole.

b) Sand Cast Iron Spigot and Socket pipe and fittings

All soil waste and vent pipes and fittings used in the work shall be cast iron and shall conform to IS:1729-1979. The pipes shall have spigot and socket ends, with bead on spigot end and shall be with or without ears. The pipes shall be free from cracks and other flaws. The interior. of the pipes and fittings shall be clean and smooth and painted inside and outside with Dr. Angus Smith's solution or other approved anticorrosive paint. Fittings shall include bends, offsets, branches of various types, junctions

	LAYING, INSTALLATION, TESTING AND COMMISSIONING OF 8" DIA. STEEL GAS PIPELINE CONNECTIVITY IN PATAN GA	
TENDER DOCUMENT NO REPL/SGL/STPL/009/22		Date: -28/11/2022

etc. as required for the work which shall be provided according to drawings and directions of the engineer.

The fittings shall be provided with access doors where so specified or directed by the engineer. The access door fittings shall be of proper design so as not to form cavities in which the filth may accumulate. Doors shall be provided with 3mm thick rubber insertion packing, and when closed and bolted they shall be watertight. The access doors shall have MS studs and bolts or screws or bolts and nuts.

Fixing

The pipes and fittings shall be fixed to wall by means of MS holder bats clamp of approved type and steel bolts or by pipe nails, bobbins etc. as the case may be, keeping the pipe clear from the finished surface of the wall. The holder bat nails shall be fixed to the wall in wooden block. The soil pipe shall be supported at the foot upon a bed of cement concrete of proportion 1:3:6 and firmly attached to the wall.

The pipes shall be laid truly vertically or along the line as shown in the drawing. Connection between main pipe and branch pipe shall be made by using branches and bends with access door for cleaning.



All vertical soil waste, ventilating and anti-siphonage pipes shall be carried up above the roof and provided with suitable C.I. cowl on top.

Pipes outside the building shall be laid underground for which trenches shall be excavated as required for the work. The trenches shall be back-filled with excavated material after the drainage system has been tested and passed.

Jointing (Lead Caulked Joint)

Unless otherwise specified, the pipes and fittings shall be jointed with lead joints as described below :

The annular space between the socket and spigot will be first well packed in with tarred gasket or hemp yarn leaving 25mm from the lip of the socket for the lead. The joint may be leaded by using proper leading rings or if they are not available by wrapping a ring of hemp rope covered with clay round the pipe at the end of the socket, leaving a hole through which lead shall be poured in (for pipes with sockets

	LAYING, INSTALLATION, TESTING AND COMMISSIONING OF 8" DIA. STEEL GAS PIPELINE CONNECTIVITY IN PATAN GA	
TENDER DOCUMENT NO REPL/SGL/STPL/009/22		Date: -28/11/2022

facing a upwards 15mm high small clay band on socket edge may be used).

The lead shall be rendered thoroughly fluid and each joint filled in one pouring. Before caulking, the projecting lead shall be removed by flat chisels and then the joint caulked round with proper caulking tools and a hammer of 2 to 3 pounds in weight in such manner as to make the joint quite sound. After being well set up the joint is to be left flush neat and even with the socket.

Lead for caulking shall conform to IS:782-1978.

Painting

All the exposed CI pipes and fittings shall be painted to match the colour of the surroundings. The surface of the pipes and fittings to be painted shall be cleaned thoroughly and painted 2 coats with approved paint over and including 1 coat of approved primer. Pipes laid underground shall be painted with 2 coats of anti-corrosive paint.

12.3.4.7 Cutting of pipes

Manufacturer's instructions shall be followed for cutting of pipes where necessary. Suitable and approved tools shall be used for the cutting so as to leave surface clean and square to the axis of the pipe.



12.3.4.8 Jointing

Jointing of laid pipes shall be so planned as to avoid completely any movement or strain to the joints already made. If any joint is suspected to be damaged it shall be opened out and redone.

All joints between pipes, pipes and fittings and man- holes shall be gas tight when above ground and watertight when underground. Method of jointing shall be as per instructions of the manufacturer and as approved by the Engineer. However, in the absence of any instruction available from the manufacturer the methods as detailed hereunder shall be used.

(a) Sand Cast Iron Pipes

Jointing of cast iron pipe shall be done as described in Sl. No. 12.3.4.7(b).

	LAYING, INSTALLATION, TESTING AND COMMISSIONING OF 8" DIA. STEEL GAS PIPELINE CONNECTIVITY IN PATAN GA	
TENDER DOCUMENT NO REPL/SGL/STPL/009/22		Date: -28/11/2022

(b) Concrete pipes

i) Spigot & Socket Joint

The opening of the joint shall be filled with stiff mixture of cement mortar 1:2 (1 cement: 2 fine sand) which shall be rammed with caulking tool.

ii) Collar Joint

Joint shall be done by slipping the collar over and clear of the end of the pipe. The recess at the end of the pipe shall be filled with jute braiding dipped in hot bitumen. Care shall be taken that no off-set of the jute braiding shall be visible either outside or inside the pipe. The collar shall be then set up over the joint covering equally both the pipes and leaving an even caulking space all round. cement and sand mortar (1:1.5) shall then be well punched or pressed home with a caulking tool.



(c) Glazed stoneware pipes

Tarred gasket or hemp yarn soaked in thick cement slurry shall first be placed round the spigot of each pipe and the spigot shall then be placed into the socket of the pipe previously laid. The pipe shall then be adjusted and fixed in the correct position and the gasket caulked tightly so as not to fill more than 1/4 of the socket. The remainder of the socket shall be filled with a stiff mixture of cement mortar of 1:1 proportion. When the socket is filled, a fillet shall be formed round the joint with a trowel, forming an angle of 45 degree with the barrel of the pipe. The newly made joints shall be protected, until set, from sun and rain and shall be covered with damp sacking or other suitable materials.

12.3.5 Trenches and other excavations

Excavation shall be carried out according to chapter-2, Earthwork.

Width of the trench at the bottom shall be such as to provide 200 mm

	LAYING, INSTALLATION, TESTING AND COMMISSIONING OF 8” DIA. STEEL GAS PIPELINE CONNECTIVITY IN PATAN GA	
TENDER DOCUMENT NO REPL/SGL/STPL/009/22		Date: -28/11/2022

clearance on either side of the pipe for facility of laying and jointing.

Excavated material shall be stacked sufficiently away from the edge of the trench. The spoil bank shall not be allowed to endanger the stability of the excavation. Spoil may be carted away and used for filling the trench behind the work. Turf, top soil or other surface material shall be set aside, turf being carefully rolled and stacked for use in reinstatement. All excavations shall be properly timbered, where necessary. Efficient arrangements for dewatering during excavation and keeping it dry till back filling shall be made to the satisfaction of the Engineer. Sumps for dewatering shall be located away from the pipe layout.

Where the excavation proceeds through roads necessary permissions shall be secured by the contractor from the appropriate authorities.

Special care shall be taken not to damage underground services, cables etc. These when exposed shall be kept adequately supported till the trench is backfilled.

The backfilling shall be done only after the pipeline has been tested and approved by the Engineer. Special care shall be taken for packing with selected material in areas 300 mm around the pipe. At least 300 mm over the pipe shall also be filled with soft earth or sand.



Consolidation shall be done in 150 mm layers. The surface water shall be prevented from getting into the filled up trench. Traffic shall not be inconvenienced by heaping up unduly the backfilling material to compensate future settlement. All settlements shall be made good regularly to minimise inconvenience or traffic where applicable.

12.3.6 Installation of fittings & fixtures

12.3.6.1 General

All fittings & fixtures shall be laid out as per drawings and in proper line, level and shall be firmly secured to floors with screws and ditto fix and to walls with wall plugs and screws. Unless otherwise specified only C.P. Brass screws shall be used for fixing sanitary fittings to wall plugs and floors.

12.3.6.2 European pattern WC

	LAYING, INSTALLATION, TESTING AND COMMISSIONING OF 8" DIA. STEEL GAS PIPELINE CONNECTIVITY IN PATAN GA	
TENDER DOCUMENT NO REPL/SGL/STPL/009/22		Date: -28/11/2022

Water closet shall be fixed with floor by means of 75 mm long, 6.5 mm diameter counter sunk bolts & nuts embedded in floor using rubber or fibre washers so as not to allow any lateral displacement.

12.3.6.3 Indian Pattern W.C.

The water closet pan shall be sunk into the floor and embedded in a cushion of average 150 mm cement concrete 1:4:8 (1 cement, 4 sand and 8 broken brick ballast of 40 mm size). The concrete shall be left about 125 mm below the top level of the pan so as to allow for flooring and its bed concrete. The joint between the pan and trap shall be made with C.M. 1:1 and joint between trap and CI soil and waste pipe to be made with lead. All the joints shall be leak proof. The WC floor shall slope towards the pan. The foot rest shall be set in cement mortar 1:3 (1 cement : 3 sand).

The cast iron cistern, brackets and flush pipe etc. shall be painted with two coats of approved paint, over and including a coat of approved priming.

12.3.6.4 Wash basin

Wash basin shall be fixed to C.I./R.S. brackets fixed in cement mortar 1:3 (1 cement :3 sand). The brackets shall be fixed to approved wooden wall plugs with screws. C.P. brass trap and union shall be connected to waste pipe if specified.

12.3.6.5 Urinals



The urinal shall be fixed to the walls with C.P. Brass screws fixed to wooden wall plugs. Urinal partitions shall be fixed to walls by making chases in walls and grouting the same in 1:2:4 cement concrete.

12.3.6.6 Mirror

Fixed type mirror shall be screwed to wall plugs with CP brass screws and shall have a backing of asbestos or similar material as specification in the item.

Swivel type mirror shall be fixed with C.P. brackets which shall be fixed to wall plugs with CP brass screws

12.3.6.7 Soap tray / toilet paper holder

	LAYING, INSTALLATION, TESTING AND COMMISSIONING OF 8" DIA. STEEL GAS PIPELINE CONNECTIVITY IN PATAN GA	
TENDER DOCUMENT NO REPL/SGL/STPL/009/22		Date: -28/11/2022

This shall be of flush mounting design and shall be housed in walls by making chases and grouting the same in cement mortar 1:3 unless otherwise specified. All other fittings shall be fixed with screw or as per manufacturer's specification

12.3.6.8 Towel rail & Toilet glass-shelf unit

This shall be fixed with CP Brass screws which shall be fixed to wall plugs.

12.3.6.9 Gully trap

This shall be fixed on 100 mm thick bed and encasement of size 600mm x 600mm x full height of trap shall be provided with cement concrete of proportion 1:4:8 with 40mm stone aggregate. The gully outlet shall be jointed to the branch drain as specified or directed by the Engineer.

12.3.6.10 Masonry chamber for Gully Trap



After fixing and testing gully and branch drain, a brick masonry chamber 300mm x 300mm x 450mm deep or as specified (internal dimensions) in cement mortar 1:4 (1 cement and 4 sand) shall be built with half brick thick wall round the gully trap from the top of the concrete. The internal faces of the chamber shall be finished smooth with 15 mm thick cement plaster (1:4) and neat cement finish. Brick wall exposed to outside shall be finished with 12 mm thick cement plaster 1:4. P.C.C. (1:2:4) band 100 mm thick shall be provided over the brick work with suitable grooves for accommodating R.C.C. cover to be supplied as per drawing and made water tight by providing suitable beading in the band.

12.3.6.11 High level flushing cistern - (fixing flushpipe & cistern)

The W.C. pan shall be connected to the cistern by G.I. 32mm dia or 40mm (O.D) high density polythene flush pipe with holder clamp and brass coupling.

12.3.6.12 Low level flushing cistern

Unless otherwise specified, it shall be connected to the closet by

	LAYING, INSTALLATION, TESTING AND COMMISSIONING OF 8" DIA. STEEL GAS PIPELINE CONNECTIVITY IN PATAN GA	
TENDER DOCUMENT NO REPL/SGL/STPL/009/22		Date: -28/11/2022

means of 40mm dia white porcelain enameled flush bend using rubber adaptor joints.

12.3.7 Septic tank and effluent disposal

12.3.7.1 Septic tank

Septic tank shall consist of the tank itself with inlet and outlets therefrom complete with all necessary earthwork and backfilling. The details of septic tank shall be as shown on drawing. This item shall also include ventilating pipe of at least 100mm dia whose top shall be provided with a suitable mosquito proof wire mesh and cowl. Generally ventilating pipe shall extend to a height of about 2 metres when the septic tank is at least 15 metres away from the nearest building and to a height of 2 metres above the top of building when it is located closer than 15 metres. Ventilating pipes can be connected to the normal soil ventilating system of the building where allowed.

12.3.7.2 Effluent disposal



The effluent from the septic tank shall be disposed by allowing it into an open channel or a body of water if the concerned authority approves or into a soak pit for absorption by soil or shall be allowed to be absorbed by soil through open jointed S.W pipes laid in a trench filled with broken bricks.

12.3.7.3 Soak Pit

Shall be complete as shown on drawing. In absence of a detailed drawing it shall consist of a 900mm dia pit 1000mm in depth below the invert level of the inlet pipe. The pit shall be lined with stone, brick or concrete blocks with dry open joints backed with at least 75 mm of clean coarse aggregate. The lining above the inlet level shall be set in cement mortar (1:6). The pit shall be filled with brick bats. Inlet pipe shall be taken down to a depth of 900mm from the top as an anti-mosquito measure.

12.3.7.4 Open jointed S.W pipes

Minimum dia of the S.W pipes shall be 200mm nominal. The trench for laying the pipes shall be minimum 600x600mm. The joints of the pipes shall be left unsealed.

	LAYING, INSTALLATION, TESTING AND COMMISSIONING OF 8” DIA. STEEL GAS PIPELINE CONNECTIVITY IN PATAN GA	
TENDER DOCUMENT NO REPL/SGL/STPL/009/22		Date: -28/11/2022

12.3.7.5 Commissioning septic tank

After the septic tank has been proved water-tight and the sewage system is checked, the tank shall be filled with water to its outlet level before the sewage is let into the tank. It shall be seeded with well digested sludge obtained from septic tank or sludge digestion tank. In the absence of digested sludge a small quantity of decaying organic matter such as digested cow dung may be introduced.

12.3.8 Manhole/Inspection chambers



Necessary excavation as required for the manhole shall be done true to dimensions and levels as shown in the drawing. The manhole chamber shall be built with brick work in C.M. 1:4 with minimum one brick thick on a base of 100mm thick cement concrete 1:4:8 with 40mm down aggregate or as specified. The concrete bed shall extend beyond the external face of brick work on all sides by at least 75mm . The thickness of wall shall be as indicated. The work shall be carefully built in English bond, the jointing faces of each brick being wall buttered with cement mortar before laying so as to ensure a full joint.

The inside of the walls shall be plastered with 15mm thick cement mortar 1:4 and finished with a floating coat of neat cement and outside shall be plastered with 12mm thick C.M. 1:4.

The channels and benching shall be done in cement concrete 1:2:4 with 20mm down stone aggregate and finished with 12mm thick cement plaster in C.M. 1:3. The channels shall be semicircular in the bottom half and of diameter equal to the sewer. Above the horizontal diameter the top edge shall be suitably rounded off. The Branch channels shall also be similarly constructed with respect to benching but at their junction with the main channel an appropriate fall suitably rounded off in the direction of flow of the main channel shall be given. The benching at the sides shall be carried up in a slope of 1 in 3.

All angles shall be rounded to 75mm radius with cement mortar 1:4 and shall be rendered smooth. The internal surfaces shall have a hard impervious finish obtained by using a steel trowel.

The manhole chamber shall be covered on top with RCC (1:2:4) slab with necessary reinforcement as per drawings. Unless otherwise specified circular type light duty M.H. cover with single seal weighting 25 kg. will be provided in each RCC cover.

	LAYING, INSTALLATION, TESTING AND COMMISSIONING OF 8" DIA. STEEL GAS PIPELINE CONNECTIVITY IN PATAN GA	
TENDER DOCUMENT NO REPL/SGL/STPL/009/22		Date: -28/11/2022

12.3.9 Testing and acceptance

12.3.9.1 Inspection before installation

All pipes, fittings and fixtures shall be inspected, before delivery at the site to see whether they conform to accepted standards. The pipes shall again be inspected on site before laying by sounding to disclose cracks. All defective items shall be clearly marked and forthwith removed from the site.

12.3.9.2 Testing of pipelines

Comprehensive tests of all pipe lines shall be made by simulating conditions of use. The method of actual test shall be decided by the Engineer. All test data shall be recorded and submitted to the Engineer for review and instruction. The Engineer's discretion regarding tolerance shall be final.



General guidance for the tests are given below :

12.3.9.3 Smoke Test

Soil, waste, vent and all other pipes, when above ground, shall be tested for gas tightness by a smoke test conducted under a pressure of 25mm water gauge and maintained for 15 minutes after all trap seals have been filled with water. The smoke is produced by burning oily waste or tar paper or similar material in the combustion chamber of a smoke machine. Chemical smokes are not satisfactory.

12.3.9.4 Water Test

For pipes other than cast iron Glazed ware and concrete pipes shall be subjected to a test pressure of at least 1.5m head of water at the highest point of the section under tests. The tolerance figure of two litres per centimetre of diameter per kilometre may be allowed during a period of 10 (ten) minutes. The test shall be carried out by suitably plugging the low end of the drain and the end of connections, if any, and filling the system with water. A knuckle bend shall be temporarily jointed in at the top end and a sufficient length of the vertical pipe jointed to it so as to provide the required test head or the top end may be plugged with a connection to a hose ending in funnel which could be raised or lowered till required head is obtained and fixed suitably for

	LAYING, INSTALLATION, TESTING AND COMMISSIONING OF 8" DIA. STEEL GAS PIPELINE CONNECTIVITY IN PATAN GA	
TENDER DOCUMENT NO REPL/SGL/STPL/009/22		Date: -28/11/2022

observation.

Subsidence of test water may be due to one or more of the following causes:

- a) Absorption by pipes and joints.
- b) Sweating of pipes or joints
- c) Leakage at joints or from defective pipes
- d) Trapped air

Allowance shall be made for (a) by adding water until absorption has ceased and after which the test proper should commence. Any leakage and the defective part of the work shall be cut and made good.

12.3.9.5 For cast iron pipes



Cast iron sewers and drains shall be tested as for glazedware and concrete pipes. The drain plug shall be suitably strutted to prevent their being forced out of the pipe during the test.

12.3.9.5.1 For straightness

- i) By inserting at the high end of the sewer or drain a smooth ball of a diameter 13mm less than the pipe bore. In the absence of obstruction, such as yarn or mortar projecting through the joints, the ball will roll down the invert of the pipe and emerge at the lower end and;
- ii) By means of a mirror at one end of the line and lamp at the other. If the pipe line is straight, the full circle of light may be observed. The mirror will also indicate obstruction in the barrel if the pipeline is not straight.

12.3.9.6 Testing septic tank

The septic tank shall be tested for water tightness. It shall be filled up with water and allowed to soak for 24 hours. Then, it shall be topped up and allowed to stand again for 24 hours and loss of level recorded. The fall shall not be more than 15mm.

	LAYING, INSTALLATION, TESTING AND COMMISSIONING OF 8” DIA. STEEL GAS PIPELINE CONNECTIVITY IN PATAN GA	
TENDER DOCUMENT NO REPL/SGL/STPL/009/22		Date: -28/11/2022

12.3.9.7 Fixtures etc.

All fixtures and fittings shall be connected by watertight joints. No dripping shall be accepted.



13.0 EXTERNAL SEWERAGE & DRAINAGE

13.1 Scope of Work

The work comprises supply, laying, testing, commissioning etc., of sewerage & drainage network as specified.

The work includes the following activities connected with the job.

- i) Supply and delivery of all required pipes and other materials including erection.
- ii) Earth work in excavation for trenches and pits/manholes.
- iii) Civil works connected with the laying/erection of pipe lines such as making holes in the walls etc., and repairing them after pipe erection, construction of pipe supports, brick / concrete manholes, preparation of concrete bedding and covering for pipe laying wherever required etc.
- iv) Laying and jointing of the pipelines as specified in this chapter
- v) Testing of the pipelines after laying as per standard tests as specified in this chapter.
- vi) Back filling of the trenches after successful and satisfactory completion of tests for the pipeline laid.
- vii) Cleaning, painting/coating and wrapping etc of pipes and fittings etc.
- viii) Commissioning of entire network laid.
- ix) Safe custody of pipes/material/equipment/work and other obligations stated elsewhere in the specification.
- x) Any other activities which are not mentioned above but essential and required.

	LAYING, INSTALLATION, TESTING AND COMMISSIONING OF 8" DIA. STEEL GAS PIPELINE CONNECTIVITY IN PATAN GA	
TENDER DOCUMENT NO REPL/SGL/STPL/009/22		Date: -28/11/2022

- xi) If specified, at road crossing the pipe shall be laid in encasing pipes, wrapped & coated M.S pipes shall be used as encasing pipes. The encasing pipe shall project beyond the berm or both sides of the road. The encasing pipe shall be supported on P.C.C saddles if the site condition warrants so.

13.2 Materials

The materials shall conform to part-I of this series. Sewerage net work in Township shall generally be of R.C.C/S.W.G pipes, R.C.C pipes being used normally for pipe sizes of 400mm dia and above. In plant area, at road crossings etc Cast Iron Pipes may be used.

13.3. Excavation of trenches & pits

Excavation shall be carried out according to Chapter of Earthwork.

Before starting earth work in excavation, temporary drainage arrangement shall be provided to prevent surface water entering the trenches and pits at the cost of Contractor.



Excavation of trenches and pits for pipelines shall be carried out in shortest possible time so as to avoid sinking of ground and consequent damage to the pipelines.

Excavation of trenches for pipelines and surface drains, shall be in exact accordance with the plans and section, alignment, levels and gradients as indicated on the drawings or as directed at site by the Engineer. The final bed must be dressed, levelled or trimmed to proper gradient and rammed with sprinkling of sand and got passed by the Engineer. No excavation shall be made below the specified levels without written permission of the Engineer. Should any excavation be taken below the specified level due to carelessness of the Contractor, he will fill in such excavation at his own expense as specified in clause 2.12.

13.4 Cast Iron Pipes

I.S 3114-1985 has to be followed in general for Laying and jointing of pipes unless otherwise specified.

13.4.1 Back filling

	LAYING, INSTALLATION, TESTING AND COMMISSIONING OF 8” DIA. STEEL GAS PIPELINE CONNECTIVITY IN PATAN GA	
TENDER DOCUMENT NO REPL/SGL/STPL/009/22		Date: -28/11/2022

For the purpose of back filling, the depth of the trench shall be considered as divided into the following three zones from the bottom of the trench to its top.

ZONE-"A" From the bottom of the trenches to the level of the center line of the pipe.

ZONE-"B" From the level of the center line of the pipe to a level 300 mm above the top of the pipe.

ZONE-"C" From a level 300 mm above the top to the top of the trench.



Trenches shall not be back filled until the pipe joints have been tested, alignment and gradient passed by the Engineer but back filling shall be done, at least from the bottom of the trench to the level of the center line of the pipe (ZONE "A") leaving 450 mm on either side of the joints uncovered, with earth till testing is completed. These joints should however be kept covered with mats, gunny, straws etc., to avoid damage to joints by temperature effects.

While back filling care should be taken to ensure that no damage should be done to the pipeline. All back fill materials shall be free from cinders, ashes, slag, refuse, rubbish, vegetables or organic material, lumpy or foreign material, boulders, rocks or stones or other materials which in the opinion of the Engineer is unsuitable or deleterious. However, materials containing stones up to 20 cm as the greatest dimension may be used in Zone-"C" unless specified otherwise herein.

Backfilling in Zone-"A" shall be done by hand with sand, fine gravel or other approved material placed in layers of 80 mm and compacted by tamping. The back filling material shall be deposited in the trench for its full width of each side of the pipe, fitting and appurtenances simultaneously.

Backfilling in Zone-"B" shall be done by hand or approved mechanical methods. Special care being taken to avoid injuring or moving the pipes. The type of back fill materials to be used and the method of placing and consolidating shall be prescribed by the Engineer to suit individual locations.

Back filling in Zone-"C" shall be done by hand or approved mechanical methods. The type of back fill materials and method of filling shall be as prescribed by the Engineer.

	LAYING, INSTALLATION, TESTING AND COMMISSIONING OF 8” DIA. STEEL GAS PIPELINE CONNECTIVITY IN PATAN GA	
TENDER DOCUMENT NO REPL/SGL/STPL/009/22		Date: -28/11/2022

Paving and metaling shall be reinstated in as good order as before removal and the Contractor shall do adequate ramming and watering of under layers to guard against subsequent settlement all at his cost.

13.4.2 Custody of pipes

The Contractor shall remain responsible for the safe custody of pipes, specials and other materials supplied by him/issued to him either free or on cost recoverable basis till these are laid installed, tested, back filled etc., and handed over to the Engineer.

The Contractor shall verify the conditions of the pipes, specials etc., at the time of receipt from sources and shall be responsible for all damages during handling, transporting, laying, installing, testing etc., and the cost of such damages shall be borne by the Contractor.

13.4.3 Erection/laying of pipelines

- i) Erection of all equipment shall be carried out with highly skilled workers.
- ii) The pipelines shall be laid and supported properly and it shall be deemed as a contractual obligation that the lines are not thrown out of alignment or lifted off during commissioning and subsequent operation.

13.4.4 Pipeline erection



All the underground pipelines shall be laid in accordance with IS : 3114-1985.

13.4.5. Handling of pipes & fittings

Unloading of pipes & fittings

While unloading, pipes shall not be dropped down from trucks on hard surface. This should be done with the help of a steadying rope and timber skids. Pipes should not be dragged, specially to the spigot end along hard surface.

Lowering of pipes & fittings

	LAYING, INSTALLATION, TESTING AND COMMISSIONING OF 8” DIA. STEEL GAS PIPELINE CONNECTIVITY IN PATAN GA	
TENDER DOCUMENT NO REPL/SGL/STPL/009/22		Date: -28/11/2022

Proper implements, tools etc. shall be provided and used by the contractor while lowering pipes & fittings in the trenches and in no case these should be dropped. Pipes over 300mm dia shall be handled with the help of chain pulley blocks with tripod supports.

Detection of cracks in pipes and fittings

The pipes and fittings shall be inspected for defects and cracks by ringing with a light hammer preferably while suspended. Smearing the outside with chalk dust helps location of the crack. If doubt persists, pouring a little Kerosene on the inside of the pipe at the suspected spot will confirm it as it will seep through.

Cleaning of pipes and fittings

All foreign materials shall be cleaned from the socket and spigot ends both from inside and outside. Every precaution shall be taken to prevent foreign material from entering the pipe while it is being laid. When pipe laying is not in progress, the open ends of the pipe shall be closed suitably.

Cutting of pipe

The cutting of pipe for inserting valves, fittings or closure pieces shall be done in a neat manner without damage to the pipe. Pipe cutting machine may be used for this purpose and in case it is not available, for large diameter pipes electric arc cutting method using a carbon or steel rod may be adopted. The pipes can be cut by using chisels also depending on the circumstances.



Permissible deflection at socket and spigot joints

Direction

On level ground the socket ends should face the upstream. When the line runs uphill the socket ends should face the upgrade.

Permissible deflection

In case it becomes necessary to deflect pipe from a straight either in the vertical or horizontal plane, due to obstructions or where long

	LAYING, INSTALLATION, TESTING AND COMMISSIONING OF 8" DIA. STEEL GAS PIPELINE CONNECTIVITY IN PATAN GA	
TENDER DOCUMENT NO REPL/SGL/STPL/009/22		Date: -28/11/2022

radius curve is permitted, the following norms shall be adhered to:-
Lead joint 2.5 degrees Rubber joints

for nominal bore	80 to 300mm	5 degrees
for nominal bore	350 to 400mm	4 degrees
for nominal bore	450 to 750mm	3 degrees

Anchor and thrust blocks

Suitable concrete thrust blocks shall be installed, wherever the thrust is appreciable, specially at dead ends and bends. In case of unbalanced also this may be required. In case of steep gradients and under influence of temperature change also thrust blocks may be required for rigidly joined pipes.

It is advisable to avoid sharp bends above 45 degrees. In soft ground as far as possible two bends should not be put together and be separated by at least one length of straight pipe.

Anchor or thrust blocks shall be generally as per IS : 5330-1984 and thrust resistant design pressure shall be equal to the test pressure.

13.4.6 Pipe jointing



The type of jointing will be defined in the detailed working drawing and Schedule of items i.e. whether they should be (i) socket and spigot with molten lead or lead wool joint or (ii) flanged joint.

13.4.6.1 Socket & spigot joints

a) Molten lead joints

Unless otherwise specified, socket and spigot joints shall be done with molten lead.

The spigot shall be cleaned of the coating, carefully entered in the socket of the adjacent pipe by one or more laps of white hampen spun yarn, sufficient yarn only being driven into the socket to leave the depth of the lead specified. The proper depth of each joint shall be tested before running the lead by passing completely round it a wooden gauge, notched out to the

	LAYING, INSTALLATION, TESTING AND COMMISSIONING OF 8” DIA. STEEL GAS PIPELINE CONNECTIVITY IN PATAN GA	
TENDER DOCUMENT NO REPL/SGL/STPL/009/22		Date: -28/11/2022

correct depth of lead, the notch being held close up against the face of the socket. The pipes shall be carefully packed underneath so that they shall bear properly throughout their whole length.

The lead shall be carefully skinned of all scale when melted in a cast iron pot or patent melting machine. The joints must be perfectly dug before being run with lead. The pipes shall again be examined for line and level and the space left in the socket shall be filled in generally by pouring in melted lead. This may be done best by using proper loading rings or if these are not available, by wrapping a ring or hemp rope, covered with clay round the pipe at the end of the sockets leaving a hole into which lead shall be poured. For large pipes, it is also necessary to leave one or more air vents around lower half of the joints. The lead shall be rendered thoroughly fluid and each joint shall be filled at one pouring. If the pipe is too large for the joint to be filled from one ladle, two or more ladles shall be used. It is to be noted that the lead should be heated to such a temperature as will ensure that it flows completely around the joint. Overheating of lead shall be avoided.

After a section of convenient length has been laid, lead caulking shall be commenced. The lead shall be freed from the loading pipe outside the socket of the other pipe with a flat chisel, and then caulked around 3 separate times, with proper caulking tools of increasing thickness and a hammer 2 to 3 kg in weight in such a manner as to make the joints sound and water tight. After being well and evenly set, the joint is to be left flush neat and even with the socket. The approximate weight of lead and spun yarn for different size of cast iron pipe socket and spigot joints, as per IS : 3114-1985 are given in the Table-I.





	LAYING, INSTALLATION, TESTING AND COMMISSIONING OF 8" DIA. STEEL GAS PIPELINE CONNECTIVITY IN PATAN GA	
TENDER DOCUMENT NO REPL/SGL/STPL/009/22		Date: -28/11/2022

TABLE - I

**QUANTITY OF LEAD AND SPUN YARN
FOR DIFFERENT SIZES OF PIPES**

Nominal of pipe mm	Lead / Joint kg
80	1.8
100	2.2
125	2.6
150	3.4
200	5.0
250	6.1
300	7.2
350	8.4
400	9.5
450	14.0
500	15.0
600	19.0
700	22.0
750	25.0
800	31.5
900	35.0
1000	41.0
1100	46.0
1200	50.0
1500	66.5

	LAYING, INSTALLATION, TESTING AND COMMISSIONING OF 8” DIA. STEEL GAS PIPELINE CONNECTIVITY IN PATAN GA	
TENDER DOCUMENT NO REPL/SGL/STPL/009/22		Date: -28/11/2022

Note : The quantities of lead given are provisional and a variation of 20% is permissible either way.



b) Lead wool joint

In the event of the Engineer specifying or permitting the use of lead wool the joint shall be made as follows :

Hempen spun yarn shall be driven into the socket and thoroughly caulked with suitable caulking tools. Lead wool shall then be introduced and this caulking shall be repeated with each turn of lead wool under which the socket is full within 3 mm and the wool of the lead wool is compressed into dense mass. The joint shall then be finally pressed with finishing tool. The table giving the quantity of lead wool and yarn to be used in different sizes of pipes is given in the Table-2

TABLE - 2

Nominal Internal dia in mm	Lead wool weight in kg	Spun yarn weight in kg
80	1.30	0.17
100	1.70	0.23
150	2.41	0.34
175	2.89	0.37
200	3.37	0.57
225	3.63	0.64
250	4.11	0.74
300	4.82	0.82
350	6.04	1.17
375	6.52	1.25
400	7.00	1.33
450	9.64	1.84

	LAYING, INSTALLATION, TESTING AND COMMISSIONING OF 8" DIA. STEEL GAS PIPELINE CONNECTIVITY IN PATAN GA	
TENDER DOCUMENT NO REPL/SGL/STPL/009/22		Date: -28/11/2022

500	10.86	1.99
Nominal Internal dia in mm	Lead wool weight in kg	Spun yarn weight in kg
600	12.79	2.83
750	15.68	3.52
825	17.12	3.88
900	18.80	4.25
1200	28.44	6.01

Note : Higher tolerance may be permitted under special circumstances depending upon site condition for quality of lead wool and spun yarn.



13.4.6.2 Flanged joints

Flanged joints should be made by painting the facing of the flanged with graphite or red lead freely. Packing should be of rubber insertion sheet or compressed fibre board and of approved thickness. The packing should be of full diameter of the flange with proper pipe hole and bolt holes cut out and even at both the inner and outer edges. All the bolts shall be tightened up evenly on all sides keeping the longitudinal axes of adjoining pipe in exactly the same straight line.

The interior of the pipe must be checked carefully so as to be free from all dust and other foreign matters as the work proceeds. For this purpose a disc plate or brush sufficiently long to pass two or more joints from the end of the pipe last laid shall be continuously drawn forward as the pipes are laid. The ends of the pipes must be securely protected preferably with wooden plugs during the process of the work. The pipes laid must not be made receptacles either for tools, cloth or any other material during progress of the work.

13.4.7 Inspection & testing

- a) If required all materials shall be inspected by the Engineer before dispatch to site. All the tests shall be carried out in the manufacturer's works and necessary test certificates shall be

	LAYING, INSTALLATION, TESTING AND COMMISSIONING OF 8" DIA. STEEL GAS PIPELINE CONNECTIVITY IN PATAN GA	
TENDER DOCUMENT NO REPL/SGL/STPL/009/22		Date: -28/11/2022

furnished as proof of such testing. The Contractor shall intimate the Engineer at least two weeks in advance for any such inspection / testing. All facilities for inspection / testing including necessary test certificates shall be provided by the Contractor at his own cost.

- b) After completion of erection all pipelines shall be inspected by the representative of the Contractor and the Engineer. Any discrepancy, defect pointed out during this inspection shall be made good by the Contractor to the entire satisfaction of the Engineer without additional cost.
- c) All pipes with valve and fittings shall be tested to 1.5 times maximum working pressure. The pressure should remain constant for a period of 8 hours. All arrangements for testing shall be done by the Contractor. Any defect found during testing shall be made good by the Contractor to the entire satisfaction of Engineer and the test shall be repeated till acceptable results are achieved. Any special tools, instrument or equipment required for these tests shall be provided by the Contractor for tests only.
- d) All oils, lubricants and other consumables required during tests and trials of different equipment shall be supplied and arranged by the Contractor at his own cost.



13.4.8 Painting

- i) All equipment, valves and other exposed steel parts shall be given a coat of red oxide, zinc chromate or red lead and two coats of final approved quality paint according to the colour scheme of the Purchaser.
- ii) **All the exposed pipes and fittings shall be painted with two coats of paints of approved quality.**

13.4.9 Commissioning

After pressure testing the main, it should be flushed with water of sufficient velocity to remove all dirt and foreign materials.

The system shall be commissioned after all necessary tests have been

	LAYING, INSTALLATION, TESTING AND COMMISSIONING OF 8" DIA. STEEL GAS PIPELINE CONNECTIVITY IN PATAN GA	
TENDER DOCUMENT NO REPL/SGL/STPL/009/22		Date: -28/11/2022

conducted successfully. All lubricants, oils, and other consumables required for commissioning of the system shall be supplied by the Contractor at no extra cost. Commissioning of the equipment to be supplied, if any, by the Owner, shall be carried out by the Contractor under guidance of the representatives of the supplier of these equipment and Engineer. Any adjustment and/or changes/rectifications that may be found necessary during commissioning of these equipment shall be carried out by the Contractor at his cost.

13.5. Stoneware Glazed Pipelines (S.W.G)

13.5.1 Back filling

Trenches shall not be back filled until the pipe joints have been tested, alignment and gradient passed by the Engineer, but back filling shall be done at least for a depth equal to the diameter of the pipe or 300 mm whichever is greater over the pipes leaving 450 mm on either side of the joints uncovered with earth till the testing is completed. These joints should however be kept covered with mats, gunny bags, straws etc., to avoid damage to joints by temperature effects.



While back filling care should be taken to ensure that no damage is done to the pipelines. The first 300 mm of filling material immediately over and around the pipe should be of soft material free from clods and stones etc. The remainder of the filling materials shall be watered and rammed in layers not exceeding 250 mm at a time.

Paving and metalling shall be reinstated in as good order as before laying of the pipelines.

Unless otherwise required by the Engineer, there shall be a minimum cover of 700 mm over the pipes and at road crossing etc., it shall not be less than 900 mm.

13.5.2 Laying of pipes

The laying of the pipelines shall commence only after the levels of the bottom of the trench at various points have been checked by the Engineer. Cracked pipes whether at the socket or in the body shall be rejected. All SW pipes shall be fitted together on the surface of the ground to ensure a proper fit before they are lowered. The spigots and sockets shall be properly cleaned and brushed, if necessary & then lowered by hand to the bottom of the trench.

	LAYING, INSTALLATION, TESTING AND COMMISSIONING OF 8" DIA. STEEL GAS PIPELINE CONNECTIVITY IN PATAN GA	
TENDER DOCUMENT NO REPL/SGL/STPL/009/22		Date: -28/11/2022

The pipes shall be carefully laid to the alignment, levels and gradients shown on the plans and sections, and great care shall be taken to prevent, sand, earth or other matter from entering the pipes during laying. As it is not permitted to rectify errors of grade by packing up underneath with earth, care should be taken in excavating and slight scraping, if necessary, done to bring to grade. The pipes between manholes shall be laid truly in straight lines without vertical or horizontal undulations.

Bedding, haunching or encasing of the pipes during laying shall be in accordance with IS : 4127-1983 and shall be done with cement concrete in proportion (1:4:8) to prevent ground water from entering the pipelines.

All inverts shall be laid from site rail fixed at the true levels, with proper boning rod. The sight rails and boning rods shall be provided, fixed and maintained by the Contractor at his own expense.

The pipes shall be laid, sockets facing up the gradient, beginning at the lower end, and with the sockets, resting in the socket rest holes cut in the trench bottom. Each pipe shall be laid singly and no pipe shall be laid until the trench has been excavated to its required depth to a distance of twenty yards in front of the pipes to be laid.



No pipes of any description shall be covered until they have been passed by the Engineer.

13.5.3 Jointing of pipes

(a) Cement joint

The stoneware pipes shall be cement jointed normally. In case, if specified so, bituminous joints shall be used. In each joint, spun yarn soaked in neat cement slurry or gasket of tarred yarn shall be passed round the joint and inserted in it by means of suitable jointing tools. More skeins of spun yarn or gasket shall then be added and well rammed home. The yarn shall be moistened to avoid absorbing moisture from cement mortar.

The yarn should be so placed as to centre the spigot of one pipe within the socket of the other and shall prevent the jointing mortar penetrating inside the pipe where it might set and

	LAYING, INSTALLATION, TESTING AND COMMISSIONING OF 8" DIA. STEEL GAS PIPELINE CONNECTIVITY IN PATAN GA	
TENDER DOCUMENT NO REPL/SGL/STPL/009/22		Date: -28/11/2022

interfere with the flow of sewage.

Yarn or gasket (cemented or tarred) so rammed shall not occupy more than one-fourth of the depth of socket.

The cement shall be thoroughly mixed with medium sand in the proportion of 1:1 (1 cement : 1 sand) and then just enough water shall be added to make the mix plastic. On no account, the mortar shall be made soft or sloppy. The mix shall then be carefully inserted by hand into the joint.

Special care shall be taken for inserting the mortar into the portion of the joint underneath the pipe. When the cement mortar has been inserted, it shall be punched or caulked into the joint with wooden caulking tools, and more cement mortar shall be added until the space of the joint has been filled completely with tightly caulked cement. No fillet of cement shall be added.

No mortar which is older than 30 minutes shall be permitted for jointing. The cement mortar joints shall be cured at least for seven days before testing.

The inside of each pipe shall be carefully wiped out with a mop or scrapper sufficiently long to pass two joints from the end of the pipe and any projecting cement shall be removed.

All pipes entering the manholes should be set in cement mortar 1:3 and a completely watertight junction effected.



(b) Bituminous joints

If specified so this joint will be used. Asphalt and sand in the ratio of 1:7 shall be boiled together and filled into the socket in a molten state with the aid of special moulds.

13.5.4 Testing of pipes

Testing of pipes shall be done wholly at contractor's expense inclusive of apparatus, provision of water etc., and/or as per IS : 4127-1983.

After cement has had time to set, the pipes shall be tested in lengths between manholes in the following 'manner'. In the lowest manhole a plug shall be inserted in the pipe. The disc in the pipe and at the upper

	LAYING, INSTALLATION, TESTING AND COMMISSIONING OF 8" DIA. STEEL GAS PIPELINE CONNECTIVITY IN PATAN GA	
TENDER DOCUMENT NO REPL/SGL/STPL/009/22		Date: -28/11/2022

manhole shall be fitted with a filling pipe with a right angle bend and an air cock. The length of pipe shall then be filled with water by means of the pipe connection on the upper disc. The air cock in the upper disc shall be kept open, while the pipeline is being filled to permit the escape of air.

When the pipes have been filled with water and air excluded, the air cock shall be shut and water shall be poured into a conical "Filler" attached to the testing and filling pipe of the disc in the uppermanhole until water remains in the filler. The testing or filling pipe shall then be raised and fastened so that the height of the pipe is six feet, which will be the usual test pressure for stone ware pipejoints.

The test will be for an hour or such longer period as may be set by the Engineer. If the water level does not fall more than 25 mm in the length of 90 metre, the test may be considered satisfactory.

If it is found that certain pipe joints are leaking, the water shall be run off and joints recaulked with cement mortar and the test repeated till it is proved by the Contractor that the joints are leak-proof.

13.5.5 Concrete bedding, haunching & encasing



Unless otherwise specified in the Schedule of Quantities, all SW pipes shall be laid in accordance with IS: 4127-1983 As per site condition haunching or/and encasing of pipes with cement concrete may be required as per clause 4.2 & 4.3 of IS 4127-1983. The concreting shall be done with 1:4:8 cement sand concrete.

Where sewers have less than 1.2 m cover at places of heavy traffic, these shall be surrounded with mass concrete if directed by the Engineer.

13.5.6 Handling of pipes

While unloading, pipes shall not be dropped from the trucks/carts on the ground. Timber skids and steadying rope should be used while unloading or lowering in trenches. To avoid damage specially to spigot end, pipes should not be dragged on the hard surface.

13.6 Manholes

	LAYING, INSTALLATION, TESTING AND COMMISSIONING OF 8" DIA. STEEL GAS PIPELINE CONNECTIVITY IN PATAN GA	
TENDER DOCUMENT NO REPL/SGL/STPL/009/22		Date: -28/11/2022

All manholes shall be of the size and type as given in the Schedule and shall be provided as per drawing or as directed by the Engineer. All the manholes shall be circular or other shape as shown in drawing. The bed shall be in cement concrete of Mark-10B (or 1:3:6 mix) (Size of coarse aggregate 40 mm and down) of 100 mm thickness or as shown in the drawing and shall be projected out 75 mm from the outside face of the wall all round. or as shown in the drawing. The working part including channeling, benching etc., made of P.C.C. shall be of grade-15C (or 1:2:4 mix). All manholes shall be plastered inside with 1:3 cement plaster 20 mm thick and finished with a floating coat of neat cement unless otherwise specified.

Concrete used for precast RCC cover slabs shall be of grade 20C (or 1:1.5:3 mix) and shall be constructed as per drawing.

The top level of manholes shall be generally 100 mm above the surrounding ground levels or as directed by the Engineer. Channeling inside the manhole shall be done in smooth bends.

The end of pipe shall be neatly built in and finished in cement mortar 1:3.

Circular medium duty Cast iron water sealed manhole cover and frames, 560 mm dia (clear opening) and nominal weight 128 kg shall be provided for each manhole and shall be in accordance with IS:1726-1991 Manhole covers with double seals (Light duty) with wt. as specified in schedule of item shall be provided within compound near the buildings if specified so. If specified heavy duty cover and frames, either circular or double triangular type, shall be provided. Step irons shall be provided with two coats of bituminous paint and shall be as per drawing.



In cases where branch pipe sewers enter the manhole or main pipe sewer at a level more than 1m, from the main sewer, a drop connection shall be provided. The extra pipe length required for this connection will be paid under item for pipelines. No other extra payment will be allowed.

All exposed surfaces of cast iron frame and cover shall be painted with two coats of bituminous painting

13.7

Marker plates

Marker plate indicating the particular service installed shall be provided

	LAYING, INSTALLATION, TESTING AND COMMISSIONING OF 8” DIA. STEEL GAS PIPELINE CONNECTIVITY IN PATAN GA	
TENDER DOCUMENT NO REPL/SGL/STPL/009/22		Date: -28/11/2022

along the routes of pipes laid below ground. These shall be of mild steel, with the type of service and direction of flow, painted on it. The markers shall be set firmly in a concrete base and installed at all corners and turning points. Over straight runs markers shall be spaced at 100 m intervals generally.

14.0 ROAD WORK

14.1 General

Road works in general shall be constructed according to the requirements to the various specifications and codes of practices of the Indian Roads Congress.

Works such as earthwork, masonry, concreting and the like, wherever they occur in association with construction of roads, shall be governed by the respective specifications of these series.

14.2 Trenching and Preparation of Subgrade



The surface of the formation of width equal to that of soling coat shall first be cut to a depth below the proposed finished level equal to the combined depth of soling and wearing coat, (due allowance being made for consolidation), and dressed parallel to the finished profile. Any roots of bushes, trees etc., shall be taken out to the full depth and the cavities thus formed shall be filled up and rammed by the contractor at his cost.

In slushy soil or in areas where water logging is frequent, adequate arrangement shall be made for drainage of the area so that the sub-soil water level is kept as low as possible.

The sub-grade shall then be consolidated with a power road roller of 8-10 tonne capacity by rolling with minimum of 5 numbers of passes till it is densely consolidated to the satisfaction of the Engineer.

Surplus earth shall be disposed of as directed by the Engineer and the areas where it is disposed of shall be neatly dressed.

All undulations of the sub-grade surface that might develop due to rolling shall be made good with earth and sub-grade re-rolled.

	LAYING, INSTALLATION, TESTING AND COMMISSIONING OF 8" DIA. STEEL GAS PIPELINE CONNECTIVITY IN PATAN GA	
TENDER DOCUMENT NO REPL/SGL/STPL/009/22		Date: -28/11/2022

14.3 Ash / Moorum Carpet

Wherever the ground is soft and slushy, ash carpet consisting of common boiler ash shall be laid to 5 cm thickness over the subgrade and then rolled. In firm ground no ash carpet is necessary and boulder soling shall be laid directly over the sub-grade. If decided by the Engineer, a bed of moorum of specified thickness shall be provided for to form a sub-grade.



14.4.1 Boulder Soling

The width of the soling coat shall be 30cm (15cm on either side) more than that of the wearing coat. Its depth shall be 15cm in cutting and 23cm in filling and made up soil, unless otherwise specified in the schedule of quantities or shown in the drawing.

The edges of the soling shall be marked out by strings and stakes. Soling stone shall be hand packed and set on edge with greatest length across the road. This shall be laid closely in position on the sub-grade, firmly set with their broadest side downwards. The joints shall be staggered. All interstices between the stones shall be wedged in with locking smaller stones well driven into gaps to ensure tight packing and complete filling of interstices. Such filling shall be carried out simultaneously with the placing in position of soling stones and shall not lag behind.

After packing, surface shall be checked with template of approved shape and high and low spots corrected by removing soling and re-packing. The top surface of the soling coat shall be perfectly true to camber and grade.

The soling shall then be thoroughly consolidated with power roller of 8-12 tonne weight depending upon the type of soling stones, starting at "edges" and working towards the centre. In case of super-elevated curve the rolling shall commence from the inside edge of the curve to the outside edge. The roller shall run over the same surface of soling at least 10 times or more till the soling coat is well consolidated to the satisfaction of the Engineer. The surface shall be checked by templates and any disturbance in grade or camber corrected after every rolling and finally consolidated. After that, at least 50mm thick moorum shall be laid on top of soling coat and rolled with water to proper compaction so that the top surface seems smooth. The rate for soling coat shall be

	LAYING, INSTALLATION, TESTING AND COMMISSIONING OF 8” DIA. STEEL GAS PIPELINE CONNECTIVITY IN PATAN GA	
TENDER DOCUMENT NO REPL/SGL/STPL/009/22		Date: -28/11/2022

inclusive of the cost of the moorum as blinding materials for which no separate payment shall be made.

14.4.2 Laterite soling

In case of laterite soling the thickness of soling shall be as follows :

- (i) For road width of 7m and above the sub-base shall consist of two layers of laterite stones 150mm maximum size. The sub-base shall be rolled to a thickness of 230mm after compaction.
- (ii) For road width of 4m to 7m, the sub-base shall consist of one layer of laterite stone of 150mm maximum size consolidated to 115mm thick.
- (iii) A layer of moorum, 33.3 % in volume of laterite, shall be spread over the laterite to a uniform thickness and rolled with 8 tonne roller with constant watering until the mixture penetrates into the voids of laterite layer. Care shall be taken to maintain the camber and slopes.

Other steps for laying, compacting etc. of the laterite soling shall be same as given under clause 14.4.1 "Boulder soling".

14.5 Kerbs



Concrete or stone kerbs, where shown in drawings, shall be fixed in position after laying and consolidation of soling. They shall be fixed true to line and level and secured in position by approved means.

14.6 Water Bound Macadam Surfacing

The construction of water bound macadam shall be carried out according to IRC : 19-1981 "Standard Specification and Code of Practice for Water Bound Macadam".

14.7 Preparation of Base and Shoulders

The subgrade shall be reshaped to the required grade and camber. Where water bound macadam is to be laid over existing black top surface, 50 mm x 50 mm furrows shall be cut in the existing surface at 1 m intervals inclined 45 degree to the centre line of the carriageway,

	LAYING, INSTALLATION, TESTING AND COMMISSIONING OF 8" DIA. STEEL GAS PIPELINE CONNECTIVITY IN PATAN GA	
TENDER DOCUMENT NO REPL/SGL/STPL/009/22		Date: -28/11/2022

before laying of coarse aggregates. Necessary arrangements shall be made for the lateral confinement of aggregates by constructing shoulders in the form of two parallel mud walls 20 x 15cm which shall be made along the outer edges of the wearing course.

14.8 Spreading Coarse Aggregate

The coarse aggregates shall be spread uniformly and evenly upon the prepared base in required quantities from stock piles along the roadside or directly from vehicles. In no case shall these be dumped in heaps directly on the base. The aggregates shall be spread to proper profile by using templates placed across the road about 6m apart. Where possible, mechanical devices shall be used to spread the aggregates uniformly.



The water bound macadam course shall be constructed in layers of not more than 75 mm thickness. However, the Engineer may permit courses of 100 mm compacted thickness to be constructed in a single layer. Each layer shall be tested by depth blocks. No segregation of large or fine particles shall be allowed.

14.9 Rolling

The coarse aggregates spread as described above shall be compacted to full width by rolling with either three wheel power roller of 6 to 10 tonnes capacity or an equivalent vibratory roller. The weight of roller shall depend on the type of coarse aggregate.

The rolling shall begin from edges and after the edges have been compacted, progress gradually towards the centre, parallel to the centre line of the road, uniformly lapping each preceding rear wheel track by one half width. On super elevated portions, rolling shall commence from the lower edge. Where screenings are to be applied, rolling shall be discontinued when the aggregates are partially compacted with sufficient voids to permit application of screenings. Where screenings are not to be applied, as in the case of crushable aggregates compaction shall be continued until the aggregates are thoroughly keyed, with no creeping of stones ahead of the roller. Slight sprinkling of water may be done during rolling, if necessary.

Rolling shall not be done when the subgrade is soft or yielding nor when it causes a wave like motion in the base course. If irregularities develop during rolling, and exceed 12 mm when tested with a 3m

	LAYING, INSTALLATION, TESTING AND COMMISSIONING OF 8” DIA. STEEL GAS PIPELINE CONNECTIVITY IN PATAN GA	
TENDER DOCUMENT NO REPL/SGL/STPL/009/22		Date: -28/11/2022

straight edge, the surface shall be loosened and aggregates added or removed before rolling again. The surface shall be checked by template for camber. In no case shall screenings be used to make up depressions.

14.10 Application of Screenings

After coarse aggregates have been rolled, screenings to fill the interstices shall be applied gradually over the surface in thin layers. Dry rolling shall be done when the screenings are being spread, so that the jarring effect of roller causes them to settle into the voids of the coarse aggregates. Damp and wet screenings shall not be used and the spreading, rolling and brooming of screenings shall be taken up on sections which can be completed within one day's operation.

14.11 Sprinkling and Grouting



After application of screenings, the surface shall be copiously sprinkled with water, swept and rolled. The sprinkling, sweeping and rolling operations shall be continued and additional screenings applied where necessary until the coarse aggregates are well blended and firmly set and a grout of screenings and water forms ahead of the wheels of the roller.

14.12 Application of Binding Material

After the application of screenings, approved binding material, where it is required to be used, shall be applied at a uniform and slow rate in two or more successive thin layers to a thickness of 2.5 cm. After each application of binding material, the surface shall be copiously sprinkled with water and the resulting slurry swept in with brooms, so as to fill the voids properly. This shall be followed by rolling with a 6-10 tonne roller, during which, water shall be applied to the wheels to wash down the binding material that may get stuck to them. The spreading of binding material, sprinkling of water, sweeping with brooms and rolling shall continue until the slurry of binding material and water forms a wave ahead of the wheels of moving roller.

14.13 Setting and Drying

After final compaction the road shall be allowed to cure overnight. Next morning, hungry spots shall be filled with screenings or binding

	LAYING, INSTALLATION, TESTING AND COMMISSIONING OF 8" DIA. STEEL GAS PIPELINE CONNECTIVITY IN PATAN GA	
TENDER DOCUMENT NO REPL/SGL/STPL/009/22		Date: -28/11/2022

material, lightly sprinkled with water and rolled. No traffic shall be allowed till the macadam sets.

14.14 Surface Evenness

The surface evenness of completed water bound macadam course in longitudinal direction shall be within 12 mm when tested with a 3 m straight edge and in cross profile within 8 mm when checked with a template.

14.15 Bituminous Pavements

14.15.1 Bitumen premix carpet with seal coat

The consolidated thickness of this type of treatment shall be 2cm/2.5cm/4cm or as specified.

14.15.1.1 Surface preparation

Water bound macadam surface on which black topping is to be provided shall be thoroughly cleaned of dust, loose materials, caked mud and other foreign material with the help of wire brush, chisel, picks etc. Cleaning shall be such as to expose the stone metal to a depth of about 6mm without dislodging the interlock of the metal. All dust and other materials thus removed shall be thrown away at a suitable place as directed by the Engineer.

Any potholes, depressions and undulations found after cleaning shall be made good with premixed chippings, and well rammed.



14.15.1.2 Tack coat

Just before the application of tack coat, the surface shall be thoroughly cleaned by brooms and then by fanning with gunny bags.

Bitumen of specified grade heated to a temperature of 177 to 188 degree 'C' shall be spread on the prepared surface uniformly at the rate of 0.75 kg/sq.m. by means of sprayers. It shall be applied just ahead of and keeping pace with, laying of premix carpet.

14.15.1.3 Preparation of mix, laying & consolidation

The stone grit (aggregate) shall be surface dry and contain not more

	LAYING, INSTALLATION, TESTING AND COMMISSIONING OF 8" DIA. STEEL GAS PIPELINE CONNECTIVITY IN PATAN GA	
TENDER DOCUMENT NO REPL/SGL/STPL/009/22		Date: -28/11/2022

than 2% moisture before use. It shall be first screened of dust and measured in boxes and then loaded into the drum mixer according to the capacity of the mixing drum in the proportion given in the table below. The aggregate shall be heated to facilitate mixing with the binder in cold weather, where so directed by the Engineer.

The binder heated in boilers, to a temperature of 149 to 177 degrees C or as specified for the grade used and maintained to that temperature, shall be drawn off from the boiler into a suitable container or in bucket gauged to show the weight of bitumen in it. This shall then be poured over the aggregate in the mixer at the correct rate of 64 Kg/cum of aggregate or as specified and mixing started and continued till aggregate is uniformly coated with bitumen.

Immediately after applying the tack coat, the hot mix shall be discharged from the mixer, carried to the road surface and spread to a thickness sufficient to achieve after consolidation the specified thickness. Rakes or drag spreaders shall be used for spreading the mixture.



When the premix has been laid for a length of 15-20 metres it shall be rolled. Rolling shall commence from edges and proceed towards the centre. The roller wheels shall be moistened continuously so as to prevent metal chips sticking to it. Any high spot or depression which become apparent shall be corrected by addition or removal of premix materials.

Further the prepared finished surface shall be protected from the traffic for 24 hrs or such period as may be specified by the Engineer.

14.15.1.4 Materials

Quantity of materials required per 100 sqm of road surface shall be as given in the table below, unless otherwise specified.

Sl. No.	Consolidated thickness of premix carpet	Stone chips (cum)	Sand (cum)	Tack coat (kg)	Binder Carpet (kg/cum)	Seal coat (kg/cum)
Using Paving bitumen 80/100 or 30/40 grade						
1.	Priming tack coat					
Sl.	Consolidated	Stone chips	Sand	Binder		



	LAYING, INSTALLATION, TESTING AND COMMISSIONING OF 8” DIA. STEEL GAS PIPELINE CONNECTIVITY IN PATAN GA	
TENDER DOCUMENT NO REPL/SGL/STPL/009/22		Date: -28/11/2022

a)	on a water bound macadam surface	75
b)	on an existing black top surface	65
2.	Carpet	
	2 cm 2.4 (10 mm nominal size)	64
	2.5 cm 3.0 (10 mm nominal size)	64
	4.0 cm 4.8 (12 mm nominal size)	64
3.	Seal Coat	
a)	Dry area (Premixed sand seal coat)	0.6 68
b)	Wet area (Liquid seal coat with chips)	0.9 98

14.15.2 Seal coat

In dry areas where rainfall is under 150cm per year a premix sand seal coat shall be applied immediately after laying the carpet. The binder shall be heated in boilers of suitable design, to the temperature appropriate to the grade of bitumen. The aggregates shall be dry and suitably heated to a temperature directed by Engineer before the same are placed in the mixer of suitable design. Mixing of binder with aggregates to the specified proportions shall be continued till the latter are thoroughly coated with binder. The mix shall be immediately transported from the mixing plant to the point of use and spread uniformly on the bituminous surface to be sealed. As soon as sufficient length has been covered with premix materials, the surface shall be rolled with 6 to 8 tonne power roller. Rolling shall be continued till the premix material completely seals the voids in the bituminous course and a smooth uniform surface is obtained.

In wet areas where rainfall is above 150cm per year a liquid seal coat with chippings (not sand) shall be applied after laying the carpet. The

	LAYING, INSTALLATION, TESTING AND COMMISSIONING OF 8” DIA. STEEL GAS PIPELINE CONNECTIVITY IN PATAN GA	
TENDER DOCUMENT NO REPL/SGL/STPL/009/22		Date: -28/11/2022

binder shall be heated in boilers of suitable design, to the temperature appropriate to the grade of bitumen and spread on the surface preferably using mechanical sprayers. Immediately following the application of the binder, stone chippings in a perfectly dry condition shall be uniformly spread on the surface. Immediately after the application of the cover material, the entire surface shall be rolled with 8-10 tonne road roller.

14.15.3 Surface dressing

The surface shall be prepared in the same way as that for premix carpet work as per 14.15.1.1. Depression or pot holes, if any, shall be repaired as indicated.

After the surface has been prepared and is in perfectly dry condition, bitumen heated in the same manner as for premix carpet, shall be sprayed over the surface preferably using mechanical sprayers. It shall be ensured that there is even and uniform distribution of bitumen on the surface. Spraying shall be carried out parallel to the centre line of the road.



Immediately following the application of bitumen, stone chippings in a perfectly dry condition, shall be uniformly and evenly spread as specified in the item, over the entire sprayed surface. Spreading may be done preferably by means of mechanical gritter. Finally the entire surface shall be broomed to ensure perfect uniform spreading.

The final surface shall be checked by means of camber board etc. The spread surface shall be rolled with 6 to 8 tonne roller till there is sufficient boundage of chippings with bitumen. The finished surface shall be thrown open to traffic on the followingday.

14.15.4 Premixed Bitumen Concrete

14.15.4.1 General

In this type of road carpet a mixture of sand and stone aggregate is used as aggregate producing a dense mixture. Seal coat is not necessary as the sand used in the mix works up to the surface and forms a seal by itself. The consolidated thickness of this type of treatment shall vary from 4cm to 7.5cm as specified.

	LAYING, INSTALLATION, TESTING AND COMMISSIONING OF 8” DIA. STEEL GAS PIPELINE CONNECTIVITY IN PATAN GA	
TENDER DOCUMENT NO REPL/SGL/STPL/009/22		Date: -28/11/2022

14.15.4.2 Surface Preparation

Same as in para 14.15.1.1 above.

14.15.4.3 Tack Coat

Same as in para 14.15.1.2 above.

14.15.4.4 Preparation of Mix, Laying & Consolidation



Para 14.15.1.3 shall generally apply except that the mixing shall be done in two stages. The stone aggregate of the the correct specified size and in the proportion shown in the table above shall be fed into the mixer to which 2/3rd of the total specified quantity of bitumen heated to the appropriate temperature shall be added. When the stone metal is well coated, the sand in the specified proportion and the balance 1/3rd quantity of total bitumen shall be fed into the mixer. Mixing shall be continued until a homogeneous mix is produced and all particles are uniformly coated with bitumen.

The premix shall be emptied on to wheel barrows or stretchers and carried to the site of work. It shall then be spread uniformly on the road surface with rakes or drag spreaders immediately after applying the tack coat to a thickness sufficient to achieve after consolidation the specified thickness. When the premix has been laid for a length of 15-20m it shall be rolled. Rolling shall commence from edges and proceed towards the centre.

The roller wheels shall be moistened continuously so as to prevent metal chips sticking to it. After preliminary rolling, all honeycombs, any high spot or depression which become apparent shall be corrected by addition or removal of premix materials. Camber and grade shall be checked at every stage to ensure correctness and any defect found shall be rectified.

14.15.4.5 Materials

Quantity of materials required per 100 sqm of road surface shall be as given in the table below unless otherwise specified.

	LAYING, INSTALLATION, TESTING AND COMMISSIONING OF 8" DIA. STEEL GAS PIPELINE CONNECTIVITY IN PATAN GA	
TENDER DOCUMENT NO REPL/SGL/STPL/009/22		Date: -28/11/2022

BINDER

Sl. No.	Thickness of consolidated bitumen concrete surfacing	Tack coat (kg)	Hot Bitumen (cut back)/ Paving Bitumen 80 / 100 grade	
			Bitumen concrete	
			Stone aggregate (kg / cum)	Sand (kg / cum)
1.	4 cm, 5 cm, 6 cm & 7.5 cm	75	560	128

Aggregate

Sl.	Thickness of compacted bitumen concrete surfacing		Stone aggregate (cum / 100 sqm)	Coarse sand (cum / 100 Sq.m)
1.	4 cm	3.8	(12mm nominal size)	1.90
2.	5cm	4.8	(20mm nominal size)	2.40
3.	6cm	5.8	(60% 40mm nominal size) (40% 25mm nominal size)	2.90
4.	7.5 cm	7.3	(60% 50mm nominal size) (40% 40mm nominal size)	3.65

The nominal size of Coarse Aggregate herein shall mean as defined below:

Sl. No.	Nominal size of coarse aggregate	Designation of IS sieve through which the aggregate shall wholly pass	Designation of IS sieve through which the aggregate shall be retained
i)	40 mm	50 mm	25 mm
ii)	25 mm	40 mm	20 mm



**LAYING, INSTALLATION,
TESTING AND COMMISSIONING
OF 8” DIA. STEEL GAS PIPELINE
CONNECTIVITY IN PATAN GA**



**TENDER DOCUMENT NO
REPL/SGL/STPL/009/22**

Date: -28/11/2022

iii)	20 mm	25 mm	12.5 mm
iv)	12 mm	20 mm	10 mm
v)	10 mm	12.5 mm	6.3 mm
vi)	6 mm	10 mm	2.36 mm

14.15.5 Surface evenness

The finished surface of premix carpet and bituminous concrete shall be tested with a straight edge 4.5 m long and any irregularity greater than 6mm shall be corrected.

14.16 Berms

Shoulders and berms shall be prepared as shown on the drawings. Work on making berms shall not lag more than 100 metres behind the water bound macadam consolidation. Suitable drains shall be cut on the berms so that the water bound macadam surface is kept drained till bituminous macadam is laid.



14.17 Kerbs

Kerbs shall be laid and set in place before completing the bituminous or concrete wearing surface as well as the wearing surface of footpath. Setting shall be done in mortar where so specified with Schedule of Items. They shall be laid and set in such a way as to obtain straight lines in the finished work, the top surface matching with the finished surface of footpath.

Where the road edge forms a curve, the kerbs shall follow such curve. Gaps shall be left as shown in drawings or as may be required to provide for drainage.

14.18 Bridges and Culverts

Bridges and culverts shall be constructed according to the specifications of Indian Roads Congress. Relevant chapters of earthwork, concrete, masonry etc., of these series shall apply.

	LAYING, INSTALLATION, TESTING AND COMMISSIONING OF 8” DIA. STEEL GAS PIPELINE CONNECTIVITY IN PATAN GA	
TENDER DOCUMENT NO REPL/SGL/STPL/009/22		Date: -28/11/2022

14.19 Boulder Pitching

Wherever specified, boulder pitching shall be provided at the inlet and outlet of pipe culverts, or for embankments of bridges. The subgrade shall first be dressed to level or slight slope as indicated. The transverse slope of the pitching shall be made strictly in accordance with the drawings or as directed by the Engineer.

14.20 Scarifying & Dismantling

Where a new carriage-way abuts or includes an existing carriage-way and the Engineer so directs, the surface of the latter shall be scarified, adjusted and reshaped to conform with the existing and new camber or crossfall. Materials from the existing road shall be used or disposed off as directed by the Engineer.



Where dismantling of the existing road has been specified, the various layers of the road viz., bituminous macadam, water-bound macadam and soling shall be scarified separately. Scarifying can be done either by hand picks, or by means of scarifiers fixed to the roller. When a roller is used for scarifying, crushing of the metal shall be avoided by moving the metal clear of roller wheels after the scarifier has passed over it. The loosened material shall then be combed by means of rakes to bring out most of the larger stone. If necessary, the larger stones thus collected shall be screened to separate fine particles if any.

The remaining metal shall then be removed and screened to recover reusable metal. Different grades of metal shall be stacked separately and measured.

14.21 Diversions

Where the construction of the road or culvert or bridge is in progress, the road shall be closed to traffic and a suitable diversion shall be provided for traffic by the Contractor, as directed by the Engineer.

The road shall be closed by the erection of barriers and suitable sign boards at both ends which shall be provided with lights at night. Both during night and during day, one man shall be posted at each barrier to suitably divert the traffic and to keep the light burning during the night.

	LAYING, INSTALLATION, TESTING AND COMMISSIONING OF 8” DIA. STEEL GAS PIPELINE CONNECTIVITY IN PATAN GA	
TENDER DOCUMENT NO REPL/SGL/STPL/009/22		Date: -28/11/2022

15.0 WATERPROOFING TO ROOFS & WATERPROOFING PAINTS

15.1 Scope

This chapter deals with different types of waterproofing on roof.

15.2 Material

The materials shall conform to Part-I.

15.3 General Workmanship



The waterproofing to roofs being specialised works the Contractor shall get these done by specialised firms/agencies.

15.4 Painting with Hot Bitumen

The surface to be painted shall be thoroughly dried and then cleaned, with wire brushes and cotton or gunny cloth, of all loose materials and scales. The surface shall further be cleaned with a piece of cloth lightly soaked in kerosene oil. Bitumen shall be brought to the site in its original container and this shall not be removed from site till the painting job is completed. Before applying the main coatings of hot bitumen paints, one coat of bituminous primer shall be applied. The number of coats of hot bitumen shall either two coats or as specified in the Schedule of Items. The bitumen of approved quality (either of grade 80/100 or 30/40) or as specified shall be applied to the surface after heating it to the manufacturer's specifications. Care shall be taken to see that no blank patches are left and the quality of bitumen to be spread shall be as specified and shall be to the satisfaction of the Engineer.

15.5 Painting with Bitumen Emulsion

Before applying, the surface shall be cleaned thoroughly. Generally two coats of Bitumen Emulsion are provided over a coat of emulsion primer. Since the painting is with emulsion, the surface need not be made dry.

	LAYING, INSTALLATION, TESTING AND COMMISSIONING OF 8" DIA. STEEL GAS PIPELINE CONNECTIVITY IN PATAN GA	
TENDER DOCUMENT NO REPL/SGL/STPL/009/22		Date: -28/11/2022

15.6 Waterproofing of Roof

15.6.1 With bitumen felt

Prior to laying the insulation, roof gradient shall be checked. If necessary, the roof shall be re-graded by screed to ensure everywhere a run off gradient of not less than 1 in 120. The screed shall consist of one part cement and four parts medium to coarse sand by volume. The screed shall be cured for 7 days. The surface shall then be cleaned of all foreign matter by wire brushing and dusting.

Waterproofing unless specified otherwise in drawings shall be the "heavy treatment type" with primer coat as described in IS : 1346-1991. The method of laying roofing treatment, surface finishing with pea gravels, special mode of treatment for drain outlets, projecting pipes, parapet walls, expansion joints, gutters, timber roofs etc., shall conform to IS : 1346-1991. The number of layers of felts shall be as specified in the drawing or Schedule of Items. The bonding bituminous material shall be of grade 30/40 or as specified and the minimum quantity of hot bitumen to be applied, shall be 1.2 kg/m². Unless specified otherwise, the bituminous felts shall be hessian bases of Type-3 Grade-2. Pea gravel finish may be substituted by a coat of bituminous aluminium paint, where so specified in the Schedule of Items.



The cement mortar used for filling the chases shall be of mix 1:4 and the cement concrete for fillets shall be of the same grade as the roof slab.

Where special surface finish with precast concrete or clay tiles is specified, it shall be in accordance with the relevant chapter of this series.

15.6.2 With bitumen mastic

The work shall be carried out generally in accordance with IS : 4365-1967 "Code of Practice for Application of Bitumen Mastic for Waterproofing of Roofs" or according to the manufacturer's specifications. The work shall be carried out by a firm of specialists in the trade.

The type of underlay or primer, thickness of application, surface finish etc., shall be as shown on drawing or described in the Schedule of

	LAYING, INSTALLATION, TESTING AND COMMISSIONING OF 8" DIA. STEEL GAS PIPELINE CONNECTIVITY IN PATAN GA	
TENDER DOCUMENT NO REPL/SGL/STPL/009/22		Date: -28/11/2022

Items. Bitumen melting shall be done in a mechanical mixer by gradually heating to about 200 degree 'C'. Coarse aggregate where required shall be added to the hot bitumen and stirred.

Each coat shall be spread evenly and uniformly by means of a float to the required thickness. Timber gauges shall be used to regulate the thickness. Particular care shall be taken to tuck the mastic into grooves on vertical surfaces, at joints, around pipes or other projections and at junction of adjoining bays.

15.6.3 Waterproofing of RCC roof with Lime concrete and Pressed clay tiles.

Lime concrete shall consist of broken brick aggregates and lime. Proportion of brickbat coba shall be 2.5 parts of brick jelly to one part of lime. The brick jelly shall be hard, well burnt and of size varying from 12mm to 25mm.



The lime concrete is then laid over roof to slope to give specified thickness and in slope of 1 in 80 or as shown on the drawing for proper roof drainage as per roof drainage plan. The lime concrete is then to be beaten in the manner approved by the Engineer for 48 hours or as directed with hand beaters.

If the surface during the process of compaction becomes so uneven that water lodges in pools, the surface shall be pricked up, and fresh concrete

spread and consolidated as necessary to obtain an even surface.

The concrete shall then be cured by sprinkling water and allowed to harden for a period of not less than six days before laying the roof finish.

Roof shall be finally finished with one course of machine pressed clay tiles 20 mm thick laid over a 12mm thick of 1:3 mix cement mortar mixed with 5% crude oil by weight of cement mixed in mortar. The pressed clay tiles shall be immersed in water for two hours before being used. The side joints of the tiles shall be more than 60 mm thick set full in mortar. Before the work dries up completely, the tile joints shall be raked out and pointed with cement mortar 1:3 mixed with crude oil which shall be 5% by mass of cement. The joints shall be well

	LAYING, INSTALLATION, TESTING AND COMMISSIONING OF 8" DIA. STEEL GAS PIPELINE CONNECTIVITY IN PATAN GA	
TENDER DOCUMENT NO REPL/SGL/STPL/009/22		Date: -28/11/2022

rubbed over with thin bar trowel and excess of mortar scrapped off until the surface of the pointing attains a black polish and becomes hard. As the work proceeds, it shall be kept thoroughly wetted until the mortar has set firm and hard. Watering shall be continued for three weeks after construction.

Lime concrete and tiles shall be taken up the parapet walls to a height of 150 mm or as shown in the drawing.

The specification of pressed clay tiles shall be as given in IS:2690-1975 (Part-I). The specification of crude oil shall be as per IS:2119-1980.

The areas around drain pipes shall be properly finished with provision of adequate slope.

The contractor shall give guarantee for any/all types of waterproofing for a period of 7 years against bad of faulty material and construction and shall rectify the same at his own cost during the guaranteed period.

15.7 Waterproofing for Basement

15.7.1 The specification covers the requirements of waterproofing of basements, tunnels, ducts, pits, bunkers, etc.



The material used shall be bitumen felt type-3 of grade-2 conforming to IS : 1322-1982, together with the specified bonding material and primer.

Waterproofing shall be provided on the outside of walls and top of the floors and shall be carried 150 mm above ground level.

The number of layers of bitumen felt to be used for walls and floor unless otherwise shown in the drawing shall be :

- i) For depths upto five metres below ground : 2 layers.
- ii) For depths beyond five metres : 3 layers.

The method of laying the bitumen felts and workmanship shall in general conform to IS : 1609-1991.

	LAYING, INSTALLATION, TESTING AND COMMISSIONING OF 8" DIA. STEEL GAS PIPELINE CONNECTIVITY IN PATAN GA	
TENDER DOCUMENT NO REPL/SGL/STPL/009/22		Date: -28/11/2022

Waterproofing work shall be taken in hand only when the sub-soil water level is at its lowest, the site shall be kept dry by adequate arrangements for pumping out water till the work has been completed. For this purpose drains shall be formed along the edges of the excavation but beyond the building line, with suitable collecting sumps. In case of large excavation areas where it is necessary to dewater under the floor, additional land drains shall be formed across the excavation, to adequately drain the area. Adequate arrangements shall be made to prevent the sides of excavation from slipping while the work is in progress.



The base concrete of mud-mat shall be rendered smooth by a 20 mm thick sand-cement plaster (6:1). Any sharp corner over which the waterproofing course is to be laid shall be eased out by means of cement mortar fillets 7.5 cm in radius.

The surface must be dry before the next operation is carried out. Blown bitumen conforming to IS : 702-1988 shall be applied hot over the prepared surface at the rate of 1.5 kg/m² for the first layer and for every other subsequent layer(s). The laying of felt over the bitumen so applied shall always commence on the floor, and shall be carried to the walls only after treatment of the floor is complete. The minimum overlapping of joints at sides and ends of felts shall be 10 cm. Joints for subsequent layers of felt shall be staggered. All joints shall be completely sealed by blow lamp.

A protective flooring of either flat bricks in cement mortar 1:3 or 6 cm thick cement concrete type M15B or a coat of cement sand plaster (1:3) 4 cm thick shall be constructed over the waterproofing treatment to prevent damage to the latter during subsequent construction of the structural floor.

The walls shall be treated in a similar way, the bitumen felts joining at the base with the projecting felt laid over the mud-mat. The wall surface shall be made smooth, where necessary with a coat of cement plaster 1:5, the felts shall be laid as for the floor ensuring that the surface to be treated is dry and then a protective brick wall, half-brick nominal thickness shall be built in cement mortar 1:6 over the projecting mud-mat, the space between the wall and felt being grouted with cement slurry. Sufficient care shall be taken to ensure a perfect bond between the waterproofing on the floor and that on the walls.

The treatment on the wall shall be carried 150 mm above the surface of

	LAYING, INSTALLATION, TESTING AND COMMISSIONING OF 8" DIA. STEEL GAS PIPELINE CONNECTIVITY IN PATAN GA	
TENDER DOCUMENT NO REPL/SGL/STPL/009/22		Date: -28/11/2022

ground and tucked into a groove 6.5 cm. wide and 7.5 cm deep, the chase being filled with cement mortar (1:4).

Where waterproofing is done to the roof of an underground structure, such as a tunnel, it shall be done in a similar way. The structural concrete shall be rendered smooth, hot bitumen and bitumen felts applied in the same way as for the floor and walls, and over this shall be laid a protective layer of cement concrete grade M10C, 7.5 cm thick.

15.7.2 With epoxy based emulsion

Over the mud-mat a 20 mm plaster is to be provided to make the surface even.

On the plastered surface of the mud-mat, three coats of epoxy based leakproof emulsion shall be applied with reasonable gap between each coat in order to permit sufficient drying time.



Precaution should be taken that during the process of rod binding if any damages happens it should be immediately rectified by making patch painting on the affected portion only and as such a complete vigilance is to be kept to rectify the defect.

After the rod binding is over the concreting should be done with high polymer based, chloride and sulphide free cement waterproofing additive/admixtures @ 2% by weight of cement all through the floor area and all through the vertically raised walls of four sides which shall remain underground upto a depth of 8 metre and above from ground level.

After the concreting and immediately after de-shuttering cleaning of the concrete surface on the external faces of the walls are to be done and then three coats of epoxy based leakproof emulsion shall be applied with a reasonable gap between the each coat before back filling. If the back filling is with hard material again a protective layer of plaster shall also be applied on the external faces of walls in order to avoid damages on the painted surface.

If the back filling is with soft sandy or alluvial soil there is no necessity for protective layer of plastering as mentioned above.

Epoxy based paint can be applied on the wet surface hence there shall be no stoppage of the normal progress of the project works.

	LAYING, INSTALLATION, TESTING AND COMMISSIONING OF 8” DIA. STEEL GAS PIPELINE CONNECTIVITY IN PATAN GA	
TENDER DOCUMENT NO REPL/SGL/STPL/009/22		Date: -28/11/2022

15.8 Surface Application

Waterproofing done by surface application of bitumen based or epoxy based material shall conform strictly to the recommendations of the manufacturer. The work shall be carried out by a firm of specialists in the trade.

15.9 Guarantee

For the waterproofing on the roof as well as for underground basements the Contractor shall give guarantee in writing for the period of 7 to 10 years as specified in the Schedule of Item. For such guarantee the Contractor shall get guarantee from the manufacturer/specialised firms and forward the same to the Engineer. However, the Contractor shall be fully responsible for the serviceability of the waterproofing treatment throughout the guarantee period and any leakage during that guarantee period shall be stopped by the Contractor at no cost to the Owner and without disturbing working facility of the Owner.

15.10 Water proofing course with Fibre glass R.P. tissue

15.10.1 Scope

This section covers the furnishing of all labour, equipment and performing all operations necessary to complete to provide water proofing course of Fibre glass R.P. tissue all in accordance with the drawing and these specifications.



15.10.2 Terminology

For the purpose of these specifications the following definitions detailed hereinafter shall apply.

15.10.3 Preparation of surfaces

Surface to receive waterproofing shall be dry, free from dirt, loose particles and foreign materials. Projections which might puncture the membrane shall be removed and voids and crevices shall be filled in prior to the start of work.

Adequate covering shall be provided during this work to avoid

	LAYING, INSTALLATION, TESTING AND COMMISSIONING OF 8" DIA. STEEL GAS PIPELINE CONNECTIVITY IN PATAN GA	
TENDER DOCUMENT NO REPL/SGL/STPL/009/22		Date: -28/11/2022

splashing or staining of the adjacent work and surfaces. Any work or surface splashed or stained shall be thoroughly cleaned to the satisfaction of the Engineer. Joints in the tissue felt in the different layers shall be staggered.

15.10.4 In built-up roofing



Application

- i) Suitable slope shall be provided in the roof as per manufacturers specifications. Heat insulation may also be provided if necessary.
- ii) Prime the plastered surface primer at the rate of 0.4 Kg/sqm. This should properly impregnate the surface and should be left till the time it is touch-dry.
- iii) Apply first coat of hot bitumen @ 1.8 Kg/sqm.
- iv) Embed first layer of fibre glass RP tissue. Overlaps shall be 100mm between the layers in either direction.
- v) Apply second coat of hot bitumen @ 1.8 Kg/sqm.
- vi) Embed second layer of fibre glass RP tissue after the surface of the first layer has become dry.
- vii) Apply third coat of hot bitumen @ 1.8 Kg/sqm.
- viii) Embed third layer of fibre glass RP tissue.
- ix) Apply fourth coat of hot bitumen @ 1.8 Kg/sqm.
- x) Finish with gravel grit @ 0.006 cum per sqm.

Guarantee

A written guarantee for the water tightness shall be taken for a minimum period of 10 years.

15.10.5 Specification

	LAYING, INSTALLATION, TESTING AND COMMISSIONING OF 8” DIA. STEEL GAS PIPELINE CONNECTIVITY IN PATAN GA	
TENDER DOCUMENT NO REPL/SGL/STPL/009/22		Date: -28/11/2022

Water proofing medium

- i) By impregnation into the fibre glass reinforcement membrane forms a monolithic mass.
- ii) Prevents the penetration of water/moisture.
- iii) Acts as a top dressing.

Layer

A single thickness of fibre glass tissue impregnated with bituminous compound.

Multiple layer

2 or more layers of fibre glass tissue laid consecutively with overlapping joints and impregnation with bitumen.

Bitumen/primer

A liquid bitumen of low viscosity which penetrates into a prepared surface upon application.

Half-brick masonry shall be of approved quality 50 class brick work in cement mortar 1:4 (1cement : 4 sand). Plaster should be in cement mortar 1:4 (1cement : 4 sand). Sand should be fine sand conforming to IS 383



Application

Suitable slope may be provided in lean concrete, if necessary. Over this, 12mm thick plaster with cement mortar 1:4 (1cement : 4 coarse sand) is to be laid.

Prime the plastered surface with primer at the rate of 0.4 Kg/sqm. This should properly impregnate the surface & then should be left till the time it is touch dry.

Water proofing shall be as follows :-

- i) Apply first coat of hot bitumen @ 2.4 Kg/sqm.

	LAYING, INSTALLATION, TESTING AND COMMISSIONING OF 8” DIA. STEEL GAS PIPELINE CONNECTIVITY IN PATAN GA	
TENDER DOCUMENT NO REPL/SGL/STPL/009/22		Date: -28/11/2022

- ii) Embed first layer of fibre glass RP tissue. Overlaps shall be 100mm between the layers in either direction.
- iii) Apply second coat of hot bitumen @ 2.4 Kg/sqm.
- iv) Embed second layer of fibre glass RP tissue after the surface of the first layer has become dry .
- v) Apply third coat of hot bitumen @ 2.4 Kg/sqm.
- vi) Embed third layer of fibre glass RP tissue after the surface of the second layer has become touch-dry.
- vii) Apply fourth coat of hot bitumen @ 2.4 Kg/sqm.
- viii) Embed fourth layer of fibre glass RP tissue after the surface of the third layer has become touch-dry.
- ix) Apply fifth coat of hot bitumen @ 2.4 Kg/sqm.
- x) A layer of 12mm thick fine sand is to be laid after completing the above operations. The layer of sand will not be applied on vertical walls.

The surface should be finished with half-brick masonry in cement mortar 1:4 (1cement : 4 coarse sand).

Guarantee



A written guarantee for the water tightness shall be taken for a minimum period of 10 years.

General

The work will be carried out by specialists in the trade. Workers shall be provided with gum boots and hand gloves. There shall be no air pockets. Corners shall be treated flush without any air pockets or voids.

Measurement

The unit will include supply of materials, transport, preparation of surface, application of water proofing treatment, plastering, masonry

	LAYING, INSTALLATION, TESTING AND COMMISSIONING OF 8" DIA. STEEL GAS PIPELINE CONNECTIVITY IN PATAN GA	
TENDER DOCUMENT NO REPL/SGL/STPL/009/22		Date: -28/11/2022

work etc., as specified herein. The measurement of the item will be in square metres nearest to the second decimal of the concrete surface which is to be damp-proofed.

15.11 Water proofing course with P.V.C sheets/membranes

15.11.1 Jointing

The adjacent lengths of the P.V.C sheets shall be jointed by giving an overlap of 25mm, one over another by sealing with the approved adhesive. A minimum width of the sheet, as specified in the item, shall be used without any joint. Jointing of the sheets, to the extent possible and practicable, shall be done at the site workshop.



15.11.2 Laying

- i) Horizontal areas: The base concrete shall be rendered smooth by cement sand plaster 1:6 mix of 20mm thick unless otherwise specified. It shall be ensured that there are no sharped crivices, projections etc which may puncture and damage the sheet. P.V.C sheets shall then be evenly laid over the smooth rendered surface while it is green.

After laying of sheets a protective cover shall be laid over it. This cover may be of 1:6 cement sand mortar bed of thickness 20mm and above, flat brick/tile soling over cement sand mortar bed, any other suitable layer or thermal insulation cover as specified in the item. However care is to be taken that sheets do not get damaged while laying the protective cover. The horizontal layer of P.V.C sheets shall be carried over to a minimum of 150mm height and tucked in to the connecting vertical walls as in the case of roof parapets, if there is no provision of continuous laying of the sheets in the adjacent vertical surface.

- ii) **Vertical surfaces**

On vertical concrete surfaces the P.V.C sheets shall be fixed along with the form work with the knobs projecting toward concrete. The sheets shall be clamped on the top of the form work to keep it in position. Concrete is then poured and knobs are locked in it. After the forms have been stripped off, all the tie bolt holes, cuts and other damages are sealed with additional patches of sheets as per manufacturer's specification.

	LAYING, INSTALLATION, TESTING AND COMMISSIONING OF 8” DIA. STEEL GAS PIPELINE CONNECTIVITY IN PATAN GA	
TENDER DOCUMENT NO REPL/SGL/STPL/009/22		Date: -28/11/2022

In case good quality of soil, completely free from foreign materials like stone piece, hard lumps and rubbish etc, is available, it can be used directly as a back fill. Otherwise a half brick wall or any other measure as specified shall be provided as a protection barrier over the projecting base of the concrete/mud mat. The top edge of the sheet shall be tucked into a chase to be subsequently sealed with cement sand mortar of 1:4 mix.

In case of sheets being laid both on horizontal and adjacent vertical surfaces, the horizontal sheets shall be carried on the vertical portion as one monolithic layer.

15.11.3 Agency

The execution work including jointing, laying and testing etc. shall be done by a specialised agency duly approved by the Engineer.

15.11.4 Testing

After laying is complete, the sheets shall be tested by an Electronic Pin hole detector for pin holes, cuts and other damages etc. All such portions shall be patched suitably with additional sheets as directed and again test checked.

15.11.5 Expansion joints



All Expansion Joints etc of dimensions as specified, shall be filled up by Polymer Sealant of pourable grade as per manufacturer's specification on the P.V.C sheets locked in the joint.

15.11.6 Guarantee

The contractor shall guarantee the water tightness and leak proofing of the structure for a period of ten years after certified completion and handing over of the jobs by furnishing a free maintenance guarantee as per prescribed format and as specified.

15.12 Waterproofing with Non-Shrink Polymeric Waterproof Grouting Compound

15.12.1 Work Included

	LAYING, INSTALLATION, TESTING AND COMMISSIONING OF 8" DIA. STEEL GAS PIPELINE CONNECTIVITY IN PATAN GA	
TENDER DOCUMENT NO REPL/SGL/STPL/009/22		Date: -28/11/2022

The Contractor shall furnish materials, labour, plant, equipment and tools to complete the work as specified and/or as shown in drawings.

15.12.2 **Materials**

Cement

Ordinary portland cement shall conform to IS : 269-1989 and portland blast furnace cement shall conform to IS : 455-1989.

Aggregates

All aggregates shall conform to IS : 383-1970 Fine aggregates shall be approved river or pit sand.

Cement waterproofing compound

All cement waterproofing compound shall conform to IS : 2645-1975 and shall be of approved quality.

Solvent less resin

High build polymeric surfacing which forms a thick resilient and flexible membrane on concrete with high resistance to oil and water.

Nozzle

15 mm dia threaded G.I. pipes of suitable length plugged at both ends.



Super plasticiser

High range water reducing admixture and integral cement waterproofer for concrete. Super plasticiser shall conform to ASTM C-194 Type F, IS: 9103-1979 & IS:2645-1975.

15.12.3 **Waterproofing of underground structures**

Waterproofing shall be carried out as per the approved manufacturer's specification and as stated below:

15.12.3.1 **Raft**

	LAYING, INSTALLATION, TESTING AND COMMISSIONING OF 8" DIA. STEEL GAS PIPELINE CONNECTIVITY IN PATAN GA	
TENDER DOCUMENT NO REPL/SGL/STPL/009/22		Date: -28/11/2022

The sub-base (PCC) of the underground structure shall be cleaned of all dirt and kept dry by continuous pumping of water. 20 mm thick plaster with cement-sand mortar (1:3) mixed with approved cement waterproofing compound as per manufacturer's specification shall be laid on top of the sub-base. The plaster shall be finished smooth with a steel trowel.

The plastered surface shall then be painted with two (2) coats of approved solvent less resin to form a thick resilient and flexible resinous membrane over the plastered surface.



Threaded nozzles of 15 mm dia and of suitable length shall be placed and fixed in a grid pattern of maximum 1.5 m centre to centre over the whole raft, prior to casting of RCC raft. Similar nozzles will also be placed along the construction joint, if any, at regular intervals not exceeding 1.5 m c/c. Adequate precaution shall be taken to keep the nozzles plugged at both ends to prevent them from getting clogged by concrete. Similar nozzles shall also be post fixed at critical points, if required. Approved super plasticiser-cum-cement waterproofer shall be added to the concrete which shall be at least M20 grade as defined by IS : 456-1978 and the water cement ratio of the concrete shall not exceed 0.45. Adequate precaution shall be taken to keep the nozzles vertical while concreting.

Approved non-shrink polymeric waterproof grouting compound mixed with cement slurry shall be injected through the nozzles under pressure by pump as per the instructions of the manufacturer. When the injection operation is over the nozzles shall be sealed with a sealing compound as per manufacturer's specification and instruction.

15.12.3.2 Vertical wall

15 mm dia threaded nozzle of suitable lengths shall be placed and fixed in a grid pattern of maximum 1.5 m centre to centre over the entire surface prior to concreting of the vertical wall. Similar nozzle are to be also fixed at construction joints, if any, y, at regular intervals not exceeding 1.5 m c/c. Adequate precaution shall be taken to keep the nozzles plugged at both the ends to avoid clogging of the nozzles by concrete. Similar nozzles shall also be post fixed at critical points, if required.

The concrete for the vertical wall shall be at least M20 grade as defined

	LAYING, INSTALLATION, TESTING AND COMMISSIONING OF 8" DIA. STEEL GAS PIPELINE CONNECTIVITY IN PATAN GA	
TENDER DOCUMENT NO REPL/SGL/STPL/009/22		Date: -28/11/2022

by IS:456-1978 having a maximum water cement ratio of 0.45. Approved super plasticiser-cum-cement waterproofer shall be added to the concrete as per the manufacturer's specification. Adequate precaution shall be taken to keep the nozzles horizontal during concreting. The exterior surface of the concrete shall be plastered with 12 mm thick cement sand mortar (1:3) mixed with approved cement waterproofing compound conforming to manufacturer's specification. The plastered surface shall then be finished smooth with a neat coat of cement slurry and painted with two coats of approved solventless resin to form a thick resilient and flexible resinous membrane over the plastered surface. Approved non-shrink polymeric waterproof grouting compound mixed with cement slurry shall be injected through the nozzles under pressure by pump as per the manufacturer's specification and shall be sealed with a sealing compound as per manufacturer's specification and instruction.

16.0 MISCELLANEOUS

16.1 False ceiling

16.1.1 Scope



This chapter deals with the specification for various types of false ceiling as listed below:

- a) Wooden ceiling (solid wood) and decorative ply.
- b) Ceiling with insulating Building Board/Particle Board etc.,
- c) A.C. Sheet and ply wood ceiling.
- d) Plaster of Paris (Gypsum Anhydrous) ceiling over wooden frame.
- e) Plaster of paris (Gypsum Anhydrous) Tiles ceiling.
- f) Wooden cover, fillets, beading for ceiling.

16.1.2 General

16.1.2.1 Materials

All materials shall be in accordance with the general specifications of

	LAYING, INSTALLATION, TESTING AND COMMISSIONING OF 8” DIA. STEEL GAS PIPELINE CONNECTIVITY IN PATAN GA	
TENDER DOCUMENT NO REPL/SGL/STPL/009/22		Date: -28/11/2022

materials, Part-I, Schedule of items and as shown in drawings.

Special finishing materials as specified in schedule of item shall be procured from the specified source and got fixed by employing skilled worker in the trade under direct supervision of the manufacturer.

16.1.3 Openings for installation of light fittings

Openings in the ceiling for installation of A/C grills, light fittings shall be provided as per drawings.

16.1.4 Recess for pelmet

Recess for the installation of pelmets shall be provided where shown in drawings along the windows/ doors.

16.1.5 Grills

Grills made of wooden, M.S., Aluminium, PVC or any other material as necessary shall be provided as indicated in the drawing.



16.1.6 Frame work

The type of frame to receive the ceiling material may be of wood, aluminium or M.S. as specified in the schedule of item and as mentioned in the drawing.

16.1.7 Wooden framing for false ceiling

Unless otherwise specified in schedule of items the wooden frame work shall be of following description:

The frame work for false ceiling shall be of approved quality teak wood scantlings, the runners shall be 75 x 50 mm size and shall be spaced at 1200 mm c/c and the battens shall be 50 x 50 mm size spaced at 600 mm c/c (approx) forming a grid of 600 x 600 mm or any other grid suitable for fixing the false ceiling material and its size. The runner and battens shall be joined by halving joint using counter sunk 6 mm bolt with washer of required length with soffit of runner and batten in perfect level. The heading joints between runners shall be made with lap joints using 2 nos. 6 mm dia counter sunk bolts with washer. Heading lap joints between battens shall be made with suitable size screws. The

	LAYING, INSTALLATION, TESTING AND COMMISSIONING OF 8" DIA. STEEL GAS PIPELINE CONNECTIVITY IN PATAN GA	
TENDER DOCUMENT NO REPL/SGL/STPL/009/22		Date: -28/11/2022

wall ends of the runner shall be embedded in the wall (50 mm deep) and shall be grouted with 1:2:4 cement concrete. The soffit of framework shall be made perfectly horizontal. The teak wood frames shall be treated with 2 coats of wood preservations treatment before fixing the tiles/boards as the case may be.

The main runners of frames shall be suspended by M.S. flat 40 x 3 mm /12mm dia M.S. round/T.S. hangers placed at 1200 mm c/c (approx), the top end of the hangers shall be hocked to R.C.C. reinforcement of slab or fixed to M.S. flat cleats installed in slab for the purpose or hooked to purlins of the trusses. The hangers may be twisted or ends of M.S. round/T.S. hanger flattened to allow for fixing the same with T.W. frame or M.S. cleats with bolts of suitable size.

For teak wood framings of shaped ceilings the spacings of frames and hangers levels of false ceiling etc., shall be required to obtain the shapes/drops and profile of the ceiling and to the requirement of ceiling material. The frames shall be locally adjusted to create openings of required sizes for installation of light fittings, grills of air conditioning system.

16.1.8 Metal framing



16.1.8.1 Galvanised pressed steel framing system

Galvanised pressed steel framing system for false ceiling shall be procured from reputed manufacturer and installed by specialist agencies under technical guidance of the manufacturer and strictly as per their specifications. Unless specified otherwise these shall consist of G.I. rectangular pipes at 900 mm c/c suspended by M.S. hanger fixed to R.C.C. slab with M.S. cleats and cross channels fixed to rectangular pipes at 450 mm c/c as per "Galvolock" system of M/s Eastern Interior Pvt Limited or equivalent. Ceiling materials shall be fixed to cross channels as per specifications of the manufacturer.

Framing shall be adjusted to provide openings for the light fittings and air-conditioning grills but these shall be supported independently and not on the framing.

16.1.8.2 Aluminium grid ceiling framing system

Framing for Aluminium grid false ceiling system shall be of reputed manufacturer Bestlok, Eezilock or equivalent. It shall consist of

	LAYING, INSTALLATION, TESTING AND COMMISSIONING OF 8" DIA. STEEL GAS PIPELINE CONNECTIVITY IN PATAN GA	
TENDER DOCUMENT NO REPL/SGL/STPL/009/22		Date: -28/11/2022

aluminium main tee and cross tee's suspended by adjustable hangers fixed to R.C.C. floor with cleats. The grid may be 600 x 600 mm, 1200 x 600 mm or as per drawings. Ceiling materials, shall be fixed to frames strictly as per manufacturers specification.

16.1.9 Fixing of Ceiling

16.1.9.1 Wooden ceiling with planks

These shall be of class of wood and thickness as specified in Schedule of items. Unless specified otherwise the width of the ceiling board shall be 100 mm to 150 mm and shall be planed true on the exposed surface. The maximum length of the finished board shall be 1800 mm. The boards/strips shall be joined with tongue and groove joints and heading joints in adjacent board of the same strip shall be square butt type neatly finished. These joints shall be staggered in alternate strip or line. The boards shall be fixed to T.W. battens by headless brass pins. Moulding beads at junctions with walls and other locations as per drawings shall be provided. Necessary opening for installation of light fittings and A/C grill shall be provided and junctions if required shall be finished with moulded beads.

The false ceiling shall finally be checked for line and level, sand papered and polished with colourless polish to achieve matt satin natural finish.



16.1.9.2 Decorative ply ceiling

These shall be with decorative selected group matched ply of Teak Ply, white cedar ply or any other approved class of veneer ply in strips, square or rectangular panel matching the ply of wall panelling, if any, in the same room and of thickness as per schedule of item and drawings.

The strip ply, square/rectangular panels shall be fixed to T.W. framework with panel pins. Moulded beads of same wood as that of ply of matching shade shall be provided at junctions with walls and as specified in drawings.

Where specific pattern of grains and shade is required the ply cut into shapes as per design may be pasted on a backing ply with adhesive and such made panels shall be fixed to framing.

The ceiling shall be checked for line, and levels and exposed surfaces

	LAYING, INSTALLATION, TESTING AND COMMISSIONING OF 8" DIA. STEEL GAS PIPELINE CONNECTIVITY IN PATAN GA	
TENDER DOCUMENT NO REPL/SGL/STPL/009/22		Date: -28/11/2022

shall be sand papered and finally polished with colourless polish to achieve matt satin natural finish.

16.1.9.3 Ceiling with insulation board/particle boards

Insulation boards shall be of approved manufacturer, shade, design and thickness as specified in schedule of items and drawings. These may be plain, textured, perforated with natural finish or with white finished surface.

The boards shall be cut to suit the panel sizes of ceiling with special tools and by skilled workmen strictly as per manufacturers specifications. The board shall be fixed to T.W. frames with brass screws or as per manufacturers recommendation and in case of metal frames as per recommendations of the manufacturer of the ceiling system. The joints where exposed shall be of uniform thickness (3 mm to 6 mm) and pattern as shown in drawings.

The ceiling shall be checked for line and level and exposed surfaces prepared appropriately to receive the paint as specified in schedule of item and drawing.



16.2. Wooden partitions

16.2.1 Scope

All materials for the wooden partitions shall be of respective class as specified in the part (I) and as mentioned in schedule of items.

16.2.1.2 Frame work

Unless otherwise specified in the schedule of items, framing for partitions shall be made of approved quality teak wood scantlings of sizes as mentioned in schedule of items and drawing. The spacing of frames shall not exceed 1200 mm c/c in both direction. The joints of the frame shall be made as per standard joinery practice using standard adhesive as described in wood work chapter. The faces of the frames to receive ply/wooden board shall be true to line, level and plumb. The frames shall be firmly secured to walls, ceilings, floors by making chases and grouting the frames in 1:2:4 cement concrete or fixing the frames with metal clamps/flats screwed to above elements. The frame shall be treated with 2 coats of wood preservative. Where the panelling material is of decorative ply of 3.5 mm to 4 mm thickness,

	LAYING, INSTALLATION, TESTING AND COMMISSIONING OF 8" DIA. STEEL GAS PIPELINE CONNECTIVITY IN PATAN GA	
TENDER DOCUMENT NO REPL/SGL/STPL/009/22		Date: -28/11/2022

commercial ply of 6 mm thickness shall be fixed to the frame work for backing purpose. Where sunk (coffered) panels are to be made, combination of single- and double-layers ply shall be used for backing to achieve level difference for sunk panels.

16.2.3 Boarding/facing for partition

a) Wooden plank/board

These shall be of class of wood and thickness as specified in the schedule of item and drawings. These shall be fixed to backing wooden frame work with counter sunk brass screws in pattern and designs, with groves, joints, beads, fillets, cover moulds as shown in drawings. The exposed surfaces shall be sand papered and polished as specified.

b) Decorative ply wood facing

These shall be with decorative teak wood/rose ply/white cedar 3.5 to 4 mm thickness of selected pieces with matching colour, texture and grains and shall be fixed to the backing ply with panel pins in pattern, design, with uniform width of joints, beads, fillets, cover mould as shown in drawings. The exposed surfaces shall be lightly sand papered finished with colourless polish to achieve matt satin finish.

c) Jolly pan (laminated) board

Where specified Jolly pan boards shall be fixed to teak wood frame work strictly as per manufacturer's specification. The boards after fixing shall be cleaned of all adhesives etc.



d) Formica facing

Formica facing shall be fixed to the backing ply with standard adhesive as described for panelling works.

16.3 Expansion and Isolation Joints

16.3.1 General

Expansion and isolation joints in concrete structures shall be provided at specific places as per details indicated on the drawings. The

	LAYING, INSTALLATION, TESTING AND COMMISSIONING OF 8” DIA. STEEL GAS PIPELINE CONNECTIVITY IN PATAN GA	
TENDER DOCUMENT NO REPL/SGL/STPL/009/22		Date: -28/11/2022

materials and types of joints shall be as specified hereinafter. In case of liquid retaining structures, additional precautions shall be taken to prevent leakage of liquids as may be specified on the drawings or as directed by the Engineer. All materials are to be procured from reliable manufacturers and must have the approval of the Engineer. Where it is the responsibility of the Contractor to supply the material, the Engineer may demand test certificates for the materials and/or instruct the Contractor to get them tested in an approved-laboratory free of cost to the Owner. Joints shall be formed true to line, level, shape, dimension and quality as per drawings and specifications. Prior approval, for the method of forming the joints, should be obtained from the Engineer before starting the work.

16.3.2 Bitumen impregnated board

Bitumen impregnated fibre board of approved manufacturer as per IS: 1838 (Part 1)-1983 may be used as fillers for expansion joints. It must be durable and waterproof. It shall be compressible and possess a high degree of rebound. The dimensions of the board should be equal to that of the joint being formed. At the exposed end, the joint shall be sealed with approved sealing compound to a depth of at least 25 mm after application of an approved primer. The sealing compound and the primer shall be applied as specified by the manufacturer.



16.3.3 Joint sealing strips

16.3.3.1 General

Joint sealing strips may be provided at the construction, expansion and isolation joints as a continuous diaphragm to contain the filler material and/or to exclude passage of water. The sealing strips will be either metallic like G.I., Aluminium or Copper, or Non-metallic like rubber or P.V.C.

Sealing strips will not have any longitudinal joint and will be procured and installed in largest practicable lengths having a minimum number of transverse joints. The jointing procedure shall be as per the manufacturer's recommendations, revised if necessary, by the Engineer. If desired by the Engineer, joints in rubber seals may have to be vulcanised.

16.3.3.2 Metal sealing strips

	LAYING, INSTALLATION, TESTING AND COMMISSIONING OF 8" DIA. STEEL GAS PIPELINE CONNECTIVITY IN PATAN GA	
TENDER DOCUMENT NO REPL/SGL/STPL/009/22		Date: -28/11/2022

Metal sealing strips shall be either G.I., Aluminium or Copper and formed straight, U-shaped, Z-shaped or any other shape and of thickness as indicated in the drawing and schedule of items and/or as instructed by the Engineer.

The transverse joints will be gas welded using brass rods and approved flux. In case it is found that the joints cannot be made leak proof, longer lap lengths and different method of brazing which will render it leak proof, will be adopted by the Contractor without any additional cost to the Owner. The edges shall be neatly crimped and bent to ensure proper bond with the concrete.

a) G.I. Strips

G.I. strips shall be minimum 1.5 mm thick and 150 mm in width unless specified otherwise. The Strips shall be strong, durable, without any rust or crease. At the joints, the overlapping should be for a minimum length of 50mm

b) Aluminium strips

Aluminium strips shall be minimum 18 SWG thick and 300 mm wide unless specified otherwise and shall conform to IS : 737-1986. A minimum lap of 50 mm length is required at the joints.

c) Copper strips



The copper strips shall be minimum 18 SWG in thickness and 300 mm width.

It should be cleaned thoroughly before use so as to expose fresh surface, without any reduction in gauge. A minimum lap of 50 mm in length is required at the joints.

16.3.3.3 Non-metallic sealing strips

These will be normally in Rubber or PVC Rubber or PVC joint seals can be of shape having any combination of the following features :

- a) Plain
- b) Central bulb

	LAYING, INSTALLATION, TESTING AND COMMISSIONING OF 8" DIA. STEEL GAS PIPELINE CONNECTIVITY IN PATAN GA	
TENDER DOCUMENT NO REPL/SGL/STPL/009/22		Date: -28/11/2022

- c) Dumb-bell or flattened ends
- d) Ribbed and corrugated wings
- e) V-shaped

Transverse joints will be allowed only under unavoidable circumstances and with the specific approval of the Engineer. The actual size and shape shall be as shown in drawings/Schedule of Items and or as directed by the Engineer.

The method of forming these joints, laps etc., shall be as specified by the Manufacturer and/or as approved by the Engineer taking particular care to match the central bulbs and the edges accurately.

a) Rubber sealing strips

The minimum thickness of rubber sealing strips shall be 3 mm and the minimum width 100 mm. The material will be natural rubber and be resistant to corrosion, abrasion and attacks from the acids, alkalies and chemicals normally encountered in service. The physical properties will be generally as follows :

Specific Gravity : 1.1 to 1.15

Shore Hardness : 65A to 75A



Tensile Strength : 25 - 30 N/mm²

Maximum Safe Continuous
Temperature : 75 Degree'C

Ultimate Elongation : Not less than 350%

b) P.V.C. sealing strips

The minimum thickness of P.V.C sealing strips will be 3 mm and the minimum width 100 mm. The material should be of good quality Polyvinyl Chloride highly resistant to tearing, abrasion and corrosion as well as to chemicals likely to come in contact with during use. The physical properties will generally be as follows :

	LAYING, INSTALLATION, TESTING AND COMMISSIONING OF 8" DIA. STEEL GAS PIPELINE CONNECTIVITY IN PATAN GA	
TENDER DOCUMENT NO REPL/SGL/STPL/009/22		Date: -28/11/2022

Specific Gravity : 1.3 to 1.35

Shore Hardness : 60A to 80A

Tensile Strength : 10 - 15 N/mm²

Maximum Safe Continuous Temperature : 70 Degree 'C'

Ultimate Elongation : Not less than 275%

16.3.4 Bitumen compound

When directed, the gap in expansion joints shall be thoroughly cleaned and bitumen compound laid as per manufacturer's specifications. The compound to be used shall be of approved manufacture and shall conform to the requirements of IS: 1834-1984.

16.4 Barbed Wire Fencing

16.4.1 Materials

16.4.1.1 Galvanised barbed wire

Barbed wire shall be properly galvanised and shall be obtained from the approved manufacturer as specified in detail in Part-1.



16.4.1.2 Other materials

The specifications of materials, for angle iron posts, concrete works, plasters, if any, and for other works, shall conform to the requirements as specified in Part-I.

16.4.2 Workmanship

The work shall comprise of the following:

- a) Excavation in ground of required dimensions with all sides vertical in any type of soil including soft rock and removing the soil and dressing it neatly.
- b) Filling the holes in full with cement concrete 1:3:6 mix, well packed, after erecting the posts in correct line, level and plumb.

	LAYING, INSTALLATION, TESTING AND COMMISSIONING OF 8" DIA. STEEL GAS PIPELINE CONNECTIVITY IN PATAN GA	
TENDER DOCUMENT NO REPL/SGL/STPL/009/22		Date: -28/11/2022

In case of any post coming at local depression, the hole may not be of full depth but the depth of concrete will always be made 60 cm raising it above ground level with necessary shuttering.

- c) Where the angle iron posts are specified in the item these shall be 50 mm x 75 mm x 6 mm unless mentioned otherwise. 10 mm dia holes with saw cuts for inserting the wires shall be made as per the spacings of barbed wire shown in drawing or as directed by the Engineer. The foot of the post shall be provided with base plate for anchorage. The spacing shall be 2.5 m or as per drawing. After inserting the wire into holes the socket is to be pressed back.
- d) Straining bolts are to be provided 15 m apart from each row of wire for maintaining proper tension in the wire and without any sag or looseness.
- e) Posts are to be painted as directed by the Engineer.

16.5 Chain link fencing

16.5.1 Scope



The work under this specification covers the supply and fixing of galvanised steel chain link fencing with galvanised steel posts chain link fabric.

16.5.2 Material

Galvanised steel chain link fabric and galvanised steel pipe posts shall be obtained from the approved manufacturer as specified in detail in Part - I .

16.5.3 Workmanship

The GI pipe posts shall be embedded in plain cement concrete not leaner than 1:4:8 foundations. The height of posts above top of foundations and spacing of post shall not be more than 3 m. The chain link fabric shall be fixed to the fencing posts with the help of stretcher galvanised bars (25 x 6 flats) which will be bolted to the lugs welded to the posts. The stretcher bars shall be provided in the lapping of fabric also.



	LAYING, INSTALLATION, TESTING AND COMMISSIONING OF 8” DIA. STEEL GAS PIPELINE CONNECTIVITY IN PATAN GA	
TENDER DOCUMENT NO REPL/SGL/STPL/015/22		Date: -28/11/2022

16.6 Concertina Coil fencing

The spacing of posts and strut shall be 3.0m apart centre to centre, unless otherwise specified or as per Engineer-in-charge to suit the dimension of the area to be fenced. Every 15th last but one end posts and corner posts shall be strutted on both sides and end posts on one side only.



Fixing of posts and struts shall be as specified in clause 4.21.8 Part II of specification.

Concertina coil fencing shall be fixed on angle iron shaped with 9 horizontal reinforced barbed tape (RBT) stud tied with GI staples and GI clips to retain horizontal including necessary bolts or GI barbedwire tied to angle iron all complete as per direction of Engineer-in-charge with reinforced barbed tape.

	LAYING, INSTALLATION, TESTING AND COMMISSIONING OF 8” DIA. STEEL GAS PIPELINE CONNECTIVITY IN PATAN GA	
TENDER DOCUMENT NO REPL/SGL/STPL/009/22		Date: -28/11/2022



SPECIFICATION FOR CIVIL WORKS

PART – III NORMS OF CEMENT CONSUMPTION

	LAYING, INSTALLATION, TESTING AND COMMISSIONING OF 8” DIA. STEEL GAS PIPELINE CONNECTIVITY IN PATAN GA	
TENDER DOCUMENT NO REPL/SGL/STPL/009/22		Date: -28/11/2022

CONTENTS

- 1. MASONRY WORK**
- 2. PLAIN/REINFORCED CONCRETE WORK**
- 3. FINISHING WORK**
- 4. FLOORING WORK**
- 5. MISCELLANEOUS ITEMS**
- 6. WATER SUPPLY/DRAINAGE & SANITARY WORKSS**

	LAYING, INSTALLATION, TESTING AND COMMISSIONING OF 8” DIA. STEEL GAS PIPELINE CONNECTIVITY IN PATAN GA	
TENDER DOCUMENT NO REPL/SGL/STPL/009/22		Date: -28/11/2022

GENERAL

For calculating the requirements of cement in various items of work the following standards will be adopted. Over the above theoretical quantity of cement, additional allowance upto plus or minus 3% shall also be allowed as certified by the engineer.

For items not covered in this standard, CPWD standards shall be followed or calculated as per uses/requirement in absence of standard norms. Cement required for enabling work and cement required for testing purposes will be taken into account for consumption purpose. However, in no case such quantity should exceed 5% of the total cement used in the work or as certified by the engineer based on actual observation whichever is less.

SI.No.	Description of Item	Cement Requirement
--------	---------------------	--------------------

MASONRY WORK

1.	Random rubble masonry with	CM 1:4	1.255 quintals per cum
2.	Random rubble masonry with	CM 1:6	0.825 quintal per cum
3.	Coursed rubble masonry in	CM 1:6	0.75 quintal per cum
4.	Brick work in	CM 1:4	0.950 quintal per cum of BW
5.	Brick work in	CM 1:6	0.625 quintal per cum of BW
6.	Half brick work in	CM 1:3	1.43 quintals per 10 sqm of area
7.	Half brick work in	CM 1:4	1.06 quintals per 10 sqm of area
8.	75mm thick brick in	CM 1:4	0.65 quintal per 10 sqm of area
9.	75mm thick brick in	CM 1:3	0.81 quintal per 10 sqm of area



**LAYING, INSTALLATION,
TESTING AND COMMISSIONING
OF 8” DIA. STEEL GAS PIPELINE
CONNECTIVITY IN PATAN GA**





TENDER DOCUMENT NO
REPL/SGL/STPL/009/22

Date: -28/11/2022

8.	Concrete grade	(i) M -20B (ii) M -20C (iii) M -20D	plus wastage and all incidentals as decided.
9.	Concrete grade	(i) M -25B (ii) M -25C (iii) M -25D	
10.	Concrete grade	(i) M -30C (ii) M -30D	
11.	Applying cement slurry on RCC slab for receiving cement concrete flooring.		2.75 kg/sqm

FINISHING

1.	6mm thick C.P. 1:4	0.280 quintal per	10 sqm area
2.	10mm thick C.P. 1:5	0.370 quintal per	10 sqm area
3.	10mm thick C.P. 1:4	0.430 quintal per	10 sqm area
4.	10mm thick C.P. 1:6	0.300 quintal per	10 sqm area
5.	12mm thick C.P. 1:3	0.734 quintal per	10 sqm area
6.	12mm thick C.P. 1:4	0.547 quintal per	10 sqm area
7.	12mm thick C.P. 1:6	0.360 quintal per	10 sqm area
8.	15mm thick C.P. 1:4	0.655 quintal per	10 sqm area
9.	15mm thick C.P. 1:6	0.440 quintal per	10 sqm area
10.	20mm thick C.P. 1:4	0.850 quintal per	10 sqm area
11.	20mm thick C.P. 1:6	0.560 quintal per	10 sqm area
12.	12mm thick bearing plaster in CM 1:4 with neat cement finish	0.590 quintal per	10 sqm area

	LAYING, INSTALLATION, TESTING AND COMMISSIONING OF 8" DIA. STEEL GAS PIPELINE CONNECTIVITY IN PATAN GA	
TENDER DOCUMENT NO REPL/SGL/STPL/009/22		Date: -28/11/2022

13.	Neat cement punning	0.200 quintal per	10 sqm area
14.	Flush or ruled or cut or weather pointing on brick work with CM 1:3	0.155 quintal per	10 sqm area
15.	Flush or ruled or cut out or weather pointing on brick work with CM 1:2	0.200 quintal per	10 sqm area
16.	Raised and cut pointing on brick work with cement mortar 1:3	0.235 quintal per	10 sqm area
17.	Flush or ruled pointing on brick flooring with cement mortar 1:4	0.075 quintal per	10 sqm area
18.	Flush or ruled pointing on brick flooring with cement mortar 1:6	0.050 quintal per	10 sqm area

FLOORING

1.	Brick on edge flooring in cement mortar 1:4	1.100 quintal per	10 sqm area
2.	Brick on edge flooring in cement mortar 1:6	0.800 quintal per	10 sqm area
3.	25mm thick (IPS) cement concrete flooring 1:2:4 (1 cement : 2 sand : 4 graded stone chips 12mm nominal size) finished with a floating coat of neat cement.	1.020 quintal per	10 sqm area
4.	40mm thick (IPS) cement concrete flooring 1:2:4 with 20mm and down stone chips finished with a floating coat of neat cement.	1.500 quintal per	10 sqm area
5.	25mm thick (IPS) flooring with base coat 19mm thick 1:2:4 using stone		



**LAYING, INSTALLATION,
TESTING AND COMMISSIONING
OF 8” DIA. STEEL GAS PIPELINE
CONNECTIVITY IN PATAN GA**



TENDER DOCUMENT NO
REPL/SGL/STPL/015/22

Date: -28/11/2022

chips 10mm nominal size and 6mm
topping coat 1:1 (1 cement : 1 stone
chips 3mm size) with a floating coat of
neat cement.

1.370 quintal per

10 sqm area

6. 40mm thick (IPS) flooring with base
coat 30mm thick 1:2:4 using stone
chips 10mm nominal size and 10mm
topping coat 1:1 (1 cement : 1 stone
chips 3 to 6mm size) with a floating
coat of neat cement.

2.320 quintal per

10 sqm area

25mm thick cast-in-situ grey terrazzo
flooring, under layer 19mm thick
cement concrete 1:2:4 with 10mm
nominal size chips and 6mm thick
topping laid in cement marble powder
mix 3:1 (3 cement : 1 marble powder)
by weight in proportion of 4:7 (4
cement marble powder mix : 7 marble
chips) by volume.

1.370 quintal per

10 sqm area

8. 40mm thick cast-in-situ grey terrazzo
flooring, under layer 30mm thick
cement concrete 1:2:4 with 10mm
nominal size chips and 10mm thick
topping laid in cement marble powder
mix 3:1 (3 cement : 1 marble powder)
by weight in proportion of 4:7
(4 cement marble powder mix : 7
marble chips) by volume.

1.575 quintal per 10 sqm area

9. 40mm thick cast-in-situ terrazzo
flooring, under layer 31mm thick
cement concrete 1:2:4 with 10mm
nominal size chips and top layer 9mm
thick with marble chips of size 4 to
7mm nominal size laid in cement



**LAYING, INSTALLATION,
TESTING AND COMMISSIONING
OF 8” DIA. STEEL GAS PIPELINE
CONNECTIVITY IN PATAN GA**



TENDER DOCUMENT NO
REPL/SGL/STPL/015/22

Date: -28/11/2022

marble powder mix 3:1 (3 cement : 1 marble powder) by weight in proportion of 4:7 (4 cement marble powder mix : 7 marble chips) by volume.

- | | | | |
|-----|--|---|----------------------------|
| a) | Dark or light shade pigment with grey cement | 1.583 quintal per 10 sqm area | |
| b) | Light shade pigment or without any (grey cement) pigment with white cement | 1.010 quintal per (grey cement)
0.580 quintal per (white cement) | 10 sqm area
10 sqm area |
| c) | Medium shade pigment with 50% grey cement and 50% white cement | 1.295 quintal per (grey cement)
0.290 quintal per (white cement) | 10 sqm area
10 sqm area |
| 10. | 40mm thick cast-in-situ terrazzo flooring, under layer 28mm thick cement concrete 1:2:4 with 10mm nominal size chips and top layer 12mm thick with marble chips of size 7 to 12mm nominal size laid in cement marble powder mix 3:1 (3 cement : 1 marble powder) by weight in proportion of 2:3 (2 cement marble powder mix : 3 marble chips) by volume. | | |
| a) | Dark or light shade pigment with grey cement | 1.705 quintal per | 10 sqm area |
| b) | Light shade pigment or without any (grey cement) pigment with white cement | 0.895 quintal per (grey cement)
0.810 quintal per (white cement) | 10 sqm area
10 sqm area |
| c) | Medium shade pigment with 50% grey cement and 50% white cement | 1.300 quintal per (grey cement) | 10 sqm area |



**LAYING, INSTALLATION,
TESTING AND COMMISSIONING
OF 8” DIA. STEEL GAS PIPELINE
CONNECTIVITY IN PATAN GA**



TENDER DOCUMENT NO
REPL/SGL/STPL/015/22

Date: -28/11/2022

		0.405 quintal per (white cement)	10 sqm area
d)	White cement without any pigment	0.895 quintal per (grey cement)	10 sqm area
		0.810 quintal per (white cement)	10 sqm area
11.	Terrazzo cast-in-situ skirting and dado, top layer 6mm thick marble chips laid in cement marble powder mix 3:1 (3 cement : 1 marble powder) by weight in proportion of 4:7 (4 cement marble : 7 marble chips) by volume.		
(A)	18mm thick with under layer 12mm thick cement plaster 1:3		
a)	Dark or light shade pigment with grey cement	1.490 quintal per	10 sqm area
b)	Light shade pigment or without any pigment with white cement.	1.090 quintal per (grey cement)	10 sqm area
		0.400 quintal per (white cement)	10 sqm area
c)	Medium shade pigment with 50% grey cement and 50% white cement	1.290 quintal per (grey cement)	10 sqm area
		0.200 quintal per (white cement)	10 sqm area
(B)	21mm thick, with under layer 15mm thick cement plaster 1:3		
a)	Dark or light shade pigment with grey cement	1.640 quintal per	10 sqm area
b)	Light shade pigment or without any pigment with white cement.	1.230 quintal per (grey cement)	10 sqm area
		0.400 quintal per	10 sqm area



**LAYING, INSTALLATION,
TESTING AND COMMISSIONING
OF 8” DIA. STEEL GAS PIPELINE
CONNECTIVITY IN PATAN GA**





TENDER DOCUMENT NO
REPL/SGL/STPL/015/22

Date: -28/11/2022

(white cement)

	c) Medium shade pigment with 50% grey cement and 50% white cement	1.430 quintal per (grey cement) 0.200 quintal per (white cement)	10 sqm area 10 sqm area
12.	Precast terrazzo tiles 20mm thick with marble chips of sizes upto 6mm laid in 25mm thick bed of lime mortar, jointed with neat cement slurry mixed with pigment		
	a) Dark shades using grey cement	0.88 quintal per	10 sqm area
	b) Light shade using white cement.	0.44 quintal per (grey cement) 0.44 quintal per (white cement)	10 sqm area 10 sqm area
	c) Medium shade using 50% grey cement and 50% white cement	0.66 quintal per (grey cement) 0.22 quintal per (white cement)	10 sqm area 10 sqm area
13.	Precast terrazzo tiles 20mm thick with marble chips of sizes upto 6mm in skirting or on walls, laid on 12mm thick cement plaster 1:3 jointed with neat cement slurry		
	a) Dark shades using grey cement	1.395 quintal per	10 sqm area
	b) Light shade using white cement.	1.175 quintal per (grey cement) 0.22 quintal per (white cement)	10 sqm area 10 sqm area
	c) Medium shade using 50% grey cement	1.285 quintal per	10 sqm area

	LAYING, INSTALLATION, TESTING AND COMMISSIONING OF 8” DIA. STEEL GAS PIPELINE CONNECTIVITY IN PATAN GA	
TENDER DOCUMENT NO REPL/SGL/STPL/015/22		Date: -28/11/2022

	and 50% white cement	(grey cement) 0.11 quintal per (white cement)	10 sqm area
14.	White glazed tiles 5, 6 or 7 mm thick in flooring, skirting and dado on 12 mm thick cement plaster 1 : 3 in base and joined with white cement, slurry etc.	0.942 quintal per (grey cement) 0.25 quintal per (white cement)	10 sqm area 10 sqm area
15.	Marble stone slab flooring over 20mm thick base of lime mortar 1:1:1 (1 lime : 1 surkhi : 1 sand) and jointed with white cement slurry etc.		
	a) 20 mm thick / 30 mm thick / 40 mm thick	0.075 quintal per (white cement)	10 sqm area
16.	Marble stone slab flooring over 20mm thick base of cement mortar 1:4 & jointed with white cement slurry etc.		
	a) 20 mm thick	1.275 quintal per (grey cement) 0.075 quintal per (white cement)	10 sqm area 10 sqm area
	b) 30 mm thick	1.290 quintal per (grey cement) 0.075 quintal per (white cement)	10 sqm area 10 sqm area
	c) 40 mm thick	1.310 quintal per (grey cement) 0.075 quintal per (white cement)	10 sqm area 10 sqm area
17.	Marble tiles 18 to 24 mm thick in risers	1.16 quintal per	10 sqm area



**LAYING, INSTALLATION,
TESTING AND COMMISSIONING
OF 8" DIA. STEEL GAS PIPELINE
CONNECTIVITY IN PATAN GA**



TENDER DOCUMENT NO
REPL/SGL/STPL/015/22

Date: -28/11/2022

	of steps, skirting, dado, walls and pillars laid on 12mm thick cement mortar 1:3 (1 cement : 3 sand) and jointed with white cement slurry	(grey cement) 0.075 quintal per (white cement)	10 sqm area
18.	Extra for each additional thickness of 5 mm granolithic layer of 1:2:4 for flooring	0.016 quintal per	10 sqm of area
19	12mm thick cement plaster skirting, dado risers of steps and edges of ground sink with CM 1:3 finished with a floating coat of neat cement.	0.800 quintal per	10 sqm of area
20	15mm thick cement plaster skirting, dado risers of steps and edges of ground sink with CM 1:3 finished with a floating coat of neat cement.	0.995 quintal per	10 sqm of area
21.	19mm thick cement plaster skirting and dado with 12mm thick backing with CM 1:3 and 7mm topping 1:1 (1 cement : 1 stone chips 3mm size) finished with a floating coat of neat cement.	1.35 quintal per	10 sqm of area
22.	25mm thick cement plaster skirting and dado with 18mm thick backing with CM 1:3 and 7mm topping 1:1 (1 cement : 1 stone chips 3mm size) finished with a floating coat of neat cement.	1.85 quintal per	10 sqm of area

MISCELLANEOUS

1.	Marble work for wall lining (Veneer work) 1.8 to 2.4 cm thick in CM 1:3 including pointing with white cement mortar 1:2 (1 white cement : 2 marble	0.715 quintal per (grey cement) 0.170 quintal per (white cement)	10 sqm of area 10 sqm of area
----	--	---	--------------------------------------



**LAYING, INSTALLATION,
TESTING AND COMMISSIONING
OF 8" DIA. STEEL GAS PIPELINE
CONNECTIVITY IN PATAN GA**





TENDER DOCUMENT NO
REPL/SGL/STPL/015/22



Date: -28/11/2022

dust)

2.	Marble work for wall lining (Veneer work) 4 cm thick in CM 1:3 including pointing with white cement mortar 1:2 (1 white cement : 2 marble dust)	1.020 quintal per (grey cement) 0.170 quintal per (white cement)	10 sqm of area 10 sqm of area
3.	Grading roof for water proofing treatment with :-		
a)	CC 1:2:4 (1 cement : 2 coarse sand : 4 stone aggregate 20mm nominal size)	3.2 quintal per	cum of Concrete
b)	CM 1:3	5.1 quintal per	cum of mortar
c)	CM 1:4	3.8 quintal per	cum of mortar
4.	Providing and fixing MS fan clamps of standard shape and size in existing RCC slab including cutting chase and making good.	0.016 quintal	each
5.	Making plinth protection 50mm thick of CC 1:3:6 (1 cement : 3 sand : 6 graded stone aggregate 20mm nominal size) over 75mm bed of dry brick ballast 40mm nominal size well rammed and consolidated and grouted with fine sand including finishing the top smooth.	1.1 quintal per	10 sqm of area
6.	Grouting with		
a)	CM 1:2	7.18 quintal per	cum
b)	CM 1:3	5.40 quintal per	cum

	LAYING, INSTALLATION, TESTING AND COMMISSIONING OF 8" DIA. STEEL GAS PIPELINE CONNECTIVITY IN PATAN GA	
TENDER DOCUMENT NO REPL/SGL/STPL/015/22		Date: -28/11/2022

7.	DPC 25mm thick (1:2:4)	0.81 quintal per	10 sqm of area
8.	Making plinth protection with bricks on edge in CM 1:6 over 7.5cm bed of dry brick aggregate 40mm nominal size rammed, consolidated and grouted with fine sand and top of bricks pointed with CM 1:2.	0.86 quintal per	10 sqm of area
9.	Providing and fixing 25mm dia GI pipe outlet in CM 1:3 including cutting and making good the walls.	0.05 quintal per	10 RM
10.	Providing and fixing 40mm dia GI pipe outlet in CM 1:3 including cutting and making good the walls.	0.075 quintal per	10 RM
11.	Providing chases 75mm wide 50mm deep in walls for conduit pipe and filling the same with CC 1:3:6	0.075 quintal per	10 RM
12.	Fixing steel windows with 1:2:4 concrete blocks	0.40 quintal per	10 sqm of area
13.	Cement-sand mortar :		
a)	1:1(1cement :1sand)	10.2 quintals per	cum
b)	1:2(1cement : 2sand)	6.8 quintals per	cum
c)	1:3(1cement : 3sand)	5.1 quintals per	cum
d)	1:4(1cement : 4sand)	3.8 quintals per	cum
e)	1:5(1cement : 5sand)	3.1 quintals per	cum
f)	1:6(1cement : 6sand)	2.5 quintals per	cum

	LAYING, INSTALLATION, TESTING AND COMMISSIONING OF 8" DIA. STEEL GAS PIPELINE CONNECTIVITY IN PATAN GA	
TENDER DOCUMENT NO REPL/SGL/STPL/015/22		Date: -28/11/2022

DRAINAGE/SANITARY & WATER SUPPLY INSTALLATIONS

1.	100mm dia AC rain water pipe l/c fittings with CM 1:2	0.725 quintal per	100 RM of pipe
2.	150mm dia AC rain water pipe l/c fittings with CM 1:2	0.82 quintal per	100 RM of pipe
3.	Fixing IWC pan with traps, pair of footrests, and flushing cistern complete	0.125 quintal	each
4.	Fixing EWC pan with trap and flushing cistern complete	0.01 quintal	each
5.	Fixing wash basin and kitchen sink	0.025 quintal	l each
6.	Fixing urinal cistern including pipes	0.025 quintal	each
7.	Fixing & finishing floor trap	0.015 quintal	each
8.	Fixing HCl pipes and specials, 100mm dia and 75mm dia including making good the walls	0.135 quintal per	10 RM of pipe
9.	Fixing GI pipes of all dia with clamps (for inside work only)	0.015 quintal per	10 RM of pipe
10.	Jointing glazed stoneware pipe with CM 1:1		
	a) 100 mm dia	2.17 quintals per	10 RM of pipe
	b) 150 mm dia	3.23 quintals per	10 RM of pipe





**LAYING, INSTALLATION,
TESTING AND COMMISSIONING
OF 8" DIA. STEEL GAS PIPELINE
CONNECTIVITY IN PATAN GA**



TENDER DOCUMENT NO
REPL/SGL/STPL/015/22



Date: -28/11/2022

11. Laying cement concrete 1:5:10 all round SW pipe including bed concrete as per standard design
- | | | | |
|----|-------------------|--------------------|----------------|
| a) | 100mm dia SW pipe | 19.24 quintals per | 100 RM of pipe |
| b) | 150mm dia SW pipe | 23.53 quintals per | 100 RM of pipe |
12. Gully chamber as per specification. 0.385 quintal each
13. Stopcock chamber as per specification 0.185 quintal each
14. Inspection chambers as per specification
- | | | | |
|----|--------------------|----------------|------|
| a) | 600x600x600mm deep | 1.43 quintals | each |
| b) | 750x600x600mm deep | 1.435 quintals | each |
| c) | 900x900x600mm deep | 1.885 quintals | each |
15. Extra depth of inspection chambers as per specification
- | | | | |
|----|------------|-------------------|-------------|
| a) | 600x600mm | 0.805 quintal per | RM of depth |
| b) | 750x600mm | 1.295 quintal per | RM of depth |
| c) | 900x900mm | 1.460 quintal per | RM of depth |
| d) | 1200x900mm | 1.835 quintal per | RM of depth |

	<p>LAYING, INSTALLATION, TESTING AND COMMISSIONING OF 8” DIA. STEEL GAS PIPELINE CONNECTIVITY IN PATAN GA</p>	
<p>TENDER DOCUMENT NO REPL/SGL/STPL/009/22</p>		<p>Date: -28/11/2022</p>

SPECIFICATION FOR CIVIL WORKS

PART – IV DIMENSIONAL TOLERANCE

	LAYING, INSTALLATION, TESTING AND COMMISSIONING OF 8" DIA. STEEL GAS PIPELINE CONNECTIVITY IN PATAN GA	
TENDER DOCUMENT NO REPL/SGL/STPL/009/22		Date: -28/11/2022



GENERAL

The materials used in construction shall, besides conforming to the specifications and standards mentioned, be the best of the existing kinds obtainable. Where a particular 'Brand' or 'Make' of material is specified such 'Brand' or 'Make' of material alone shall be used.



A high standard of workmanship and accuracy shall be achieved in all sections and parts of the work. The workmanship shall be in accordance with the latest and the best civil engineering practice.

The Contractor shall ensure that all sections of the work are carried out with utmost care to achieve the dimensions shown in drawings or specifications. Where special and close tolerances are required in any particular section of work, these will be shown in the drawing and such tolerances shall be met. In the absence of such specific mention in drawings the following dimensional deviations may be tolerated, provided they do not impair the appearance or render the particular section of work unacceptable to the purpose for which it is intended. Tolerance for materials and workmanship not covered in this part as mentioned hereinafter will be in accordance with the relevant IS code.

Description	Permissible tolerance
Building bricks, in length width and height	: As per IS 1077 - 1992
Laterite stone, in length, width & height	: Plus or minus 5 mm
<u>Natural building stone</u>	
a) For stones required in ashlar masonry :	
Length & Breadth	: Plus or minus 5mm
Height	: Plus or minus 3mm
b) For stones required other than in ashlar masonry :	
Length & Breadth	: Plus 5mm, minus 10mm
Height	: Plus 5mm, minus 5mm

	LAYING, INSTALLATION, TESTING AND COMMISSIONING OF 8" DIA. STEEL GAS PIPELINE CONNECTIVITY IN PATAN GA	
TENDER DOCUMENT NO REPL/SGL/STPL/009/22		Date: -28/11/2022

Description	Permissible tolerance
Concrete and reinforced concrete pipes :	
Length :	Plus or minus 1% of standard length
Internal diameter, upto 300 mm :	Plus 3 mm Minus 1.5 mm
 <u>Cast iron spigot & socket pipes and fittings :</u>	
Length of fittings :	Plus or minus 10mm
Length of pipe :	Plus or minus 20mm
Thickness :	minus 1 mm
Internal dia of socket :	Plus or minus 3 mm
Depth of socket :	Plus or minus 10mm
External dia, upto 75 mm :	Plus or minus 3mm
100 mm :	Plus or minus 3.5mm
150 mm :	Plus or minus 4mm
 <u>Stoneware pipes, in length</u>	
upto 75 cm :	Plus or minus 10mm
Upto 90 cm :	Plus or minus 15mm
In thickness of barrel and socket not exceeding 450mm :	Plus or minus 2mm



	LAYING, INSTALLATION, TESTING AND COMMISSIONING OF 8" DIA. STEEL GAS PIPELINE CONNECTIVITY IN PATAN GA	
TENDER DOCUMENT NO REPL/SGL/STPL/009/22		Date: -28/11/2022

Description	Permissible tolerance
--------------------	------------------------------

In thickness of barrel and socket between 500 to 600mm	: Plus or minus 3mm
Glazed tiles, length of all 4 sides	: Plus or minus 0.8mm
Individual dimensions and thickness	: Plus or minus 0.5 mm
Metal doors, windows and ventilators - In overall dimension	: Plus or minus 1.5 mm
Wooden doors, windows, ventilators Overall dimension of door, window, ventilators	: Plus or minus 3 mm
All components of shutter except glazing bar	
Width	: Plus or minus 3 mm
Thickness	: Plus or minus 1 mm
Glazing bar, width & thickness	: Plus or minus 1 mm

Mild steel tubes, tubulars and other wrought steel fittings

a)	Thickness	
	i) butt welded light tubes	: Plus not limited minus 8%
	medium and heavy tubes	: plus not limited minus 10%
	ii) seamless tubes	: plus not limited minus 12.5%
b)	Weight	
	i) single tube (irrespective of the quantity)	: + 10% , - 8%

	LAYING, INSTALLATION, TESTING AND COMMISSIONING OF 8" DIA. STEEL GAS PIPELINE CONNECTIVITY IN PATAN GA	
TENDER DOCUMENT NO REPL/SGL/STPL/009/22		Date: -28/11/2022

- ii) for quantity of less than 150m of size one : + 10% , - 8%
- iii) for quantity of 150m and over of size one : + 4% , - 4%

Earth work



- Finished level of site levelling in hard rock : Plus or minus 50mm
- Finished level of site levelling except for hard rock : Plus or minus 100 mm
- Level of pits, trenches foundations : Plus or minus 50mm

Concrete & Reinforced concrete

- Footings, plan dimension : Plus 50 mm Minus 12 mm
- Eccentricity : 0.02 times the dimension of footing in the direction limited to 50 mm
- Thickness : Plus or minus 0.05 times the specified thickness

Foundations

- Deviation of planes and lines of their intersection from vertical or inclination along full height : Plus or minus 20 mm
- Deviation of horizontal plane from horizontal line
- for 1 m of the plane in any direction : Plus or minus 5mm
- for the whole plane : Plus or minus 20mm

	LAYING, INSTALLATION, TESTING AND COMMISSIONING OF 8" DIA. STEEL GAS PIPELINE CONNECTIVITY IN PATAN GA	
TENDER DOCUMENT NO REPL/SGL/STPL/009/22		Date: -28/11/2022

Sizes of cross section : Plus or minus 8mm

Surfaces of inserts to support loads : Plus or minus 5mm

Length of elements : Plus or minus 20 mm

Equipment foundations :

Top level of bolt : Plus 20mm

Top level of foundation before grouting : Minus 20mm

Axes of anchor bolts in plan : Plus or minus 5mm

Axis of foundation in either direction : Plus or minus 10mm

Deviation in vertical line along height : Plus or minus 10mm

Sizes of pits in plan : Plus or minus 20 mm

Sizes of steps in plan : minus 20mm

Levels of steps, benches and pits : minus 20mm

Axes of inserts in plan : Plus or minus 10 mm

Basic dimensions in plan : Plus or minus 10mm



Deviation of horizontal plan from horizontal line
for 1 m of plane in any direction : Plus or minus 5mm

for the whole plane : Plus or minus 20mm



Local deviations of top surface when checked
with a 2 m long straight edge : Plus or minus 8mm

Buildings :

Surfaces when checked with a 2 m long

	LAYING, INSTALLATION, TESTING AND COMMISSIONING OF 8” DIA. STEEL GAS PIPELINE CONNECTIVITY IN PATAN GA	
TENDER DOCUMENT NO REPL/SGL/STPL/009/22		Date: -28/11/2022

straight edge	:	Plus or minus 8mm
Sizes of cross section	:	Plus 8mm Minus 0 mm
Length of elements	:	Plus or minus 20mm
Deviation from horizontal plane, for whole building	:	Plus or minus 10mm
Plumb in verticality	:	1 in 1000 of height
for columns supporting floor beams	:	Plus or minus 10mm
for framed columns linked with crane girders and beams	:	Plus or minus 10mm
Reinforced concrete walls	:	Length : Plus or minus 20mm
Flatness of surface when checked with a 2 m long straight edge	:	Plus or minus 8mm
Level of top surface to support assembled elements	:	Plus or minus 5mm
Deviation in planes and lines of intersection from vertical	:	Plus or minus 15mm
Size of cross section	:	Plus or minus 8mm
Placing of reinforcement :		
Length of bar upto 75 cm long (Other than straight bars)	:	Plus 3 mm Minus 5 mm
75 - 150 cm long	:	Plus 5 mm Minus 10 mm
150 - 250 cm long	:	Plus 6 mm Minus 15 mm
250 cm long and above	:	Plus 7 mm Minus 25 mm

	LAYING, INSTALLATION, TESTING AND COMMISSIONING OF 8" DIA. STEEL GAS PIPELINE CONNECTIVITY IN PATAN GA	
TENDER DOCUMENT NO REPL/SGL/STPL/009/22		Date: -28/11/2022



Straight bars, all lengths	:	Plus or minus 25 mm
Spacing of bars	:	Plus or minus 5 mm
Anchor bolts :		
Shift in location in plan	:	Plus or minus 5 mm
Same, when bolts are located outside of structural columns	:	Plus or minus 10mm
Top level	:	Plus 20 mm
Threaded length	:	Plus 30 mm

For Walls

For Pillars

Masonry

Width	:	Plus or minus 10 mm	Plus or minus 10 mm
Shift in axes	:	Plus or minus 10 mm	--- ---
Deviation in row from horizontal line for every 10m length	:	Plus or minus 15 mm	--- ---
Flatness of surface when checked with a 2 m long straight edge	:	Plus or minus 10 mm	Plus or minus 5 mm

	LAYING, INSTALLATION, TESTING AND COMMISSIONING OF 8" DIA. STEEL GAS PIPELINE CONNECTIVITY IN PATAN GA	
TENDER DOCUMENT NO REPL/SGL/STPL/009/22		Date: -28/11/2022

Deviation in lines separating
storeys Deviation of surface
from vertical and and at angles
and corners : Plus or minus 15
mm

for 1 storey : Plus or minus 10
mm

for whole building : Plus or minus 30
mm

Dimensions of openings for
doors, windows etc : Plus 15 mm
Minus 0 mm

Flooring, skirting, dado and
plastering :

Insitu concrete floor : 4 mm



Concrete tile and mosaic, in
any 3 m length : 3 mm

in large open area : 15 mm

wall tiling - surface should not
vary from general plane by
more than 1 in 200. Marble and
such superior work, in any 2 m
length : 1.5 mm

in any row : 3 mm

Plastered surfaces, flatness
when checked with a 2 m long
straight edge : 3 mm

	LAYING, INSTALLATION, TESTING AND COMMISSIONING OF 8" DIA. STEEL GAS PIPELINE CONNECTIVITY IN PATAN GA	
TENDER DOCUMENT NO REPL/SGL/STPL/009/22		Date: -28/11/2022

Vertical surfaces, upto 1 storey : 5 mm

Over full heights : 10 mm

Metallic Inserts on assembled components length and width : Plus or minus 3 mm

Road work



The levels of the sub-grade and different pavement courses should not vary from those calculated with reference to the longitudinal and cross-sections of the road as shown on the drawing beyond the tolerance given below :-

Sub-grade : plus or minus 25mm

Sub-base : plus or minus 20mm



Base : plus or minus 15mm

Wearing course : plus or minus 6mm

	LAYING, INSTALLATION, TESTING AND COMMISSIONING OF 8" DIA. STEEL GAS PIPELINE CONNECTIVITY IN PATAN GA	
TENDER DOCUMENT NO REPL/SGL/STPL/009/22		Date: -28/11/2022



SPECIFICATION FOR CIVIL WORKS

PART – V METHOD OF MEASUREMENT

	LAYING, INSTALLATION, TESTING AND COMMISSIONING OF 8” DIA. STEEL GAS PIPELINE CONNECTIVITY IN PATAN GA	
TENDER DOCUMENT NO REPL/SGL/STPL/009/22		Date: -28/11/2022

CONTENTS

1.0	GENERAL
2.0	EARTHWORK
3.0	ANTI - TERMITE TREATMENT
4.0	CONCRETE (PLAIN & REINFORCED)
5.0	MASONRY
6.0	PLASTERING
7.0	WHITE WASHING, COLOUR WASHING & PAINTING
8.0	FLOORING, PAVING & FACING WORKS
9.0	WOODWORK
10.0	METAL DOORS, WINDOWS & VENTILATORS
11.0	GLAZING
12.0	WATER SUPPLY, DRAINAGE, SEWERAGE & SANITATION
13.0	WATER PROOFING, DAMP PROOFING
14.0	CEILING AND LINING
15.0	ROAD WORK

	LAYING, INSTALLATION, TESTING AND COMMISSIONING OF 8" DIA. STEEL GAS PIPELINE CONNECTIVITY IN PATAN GA	
TENDER DOCUMENT NO REPL/SGL/STPL/009/22		Date: -28/11/2022

1.0 GENERAL

- 1.1 The method of measurement of the various items of work shall be in accordance with IS : 1200 (Part 1 to 28) - 1971 to 1993 unless otherwise mentioned in this part or in the schedule of items or in preamble or in the specification.
- 1.2 If there is any contradiction in meaning between any portion of this part and that of IS :1200 (Part 1 to 28) - 1971 to 1993, the stipulation of this part shall prevail.
- 1.3 The descriptions and explanations given herein have as much forces as though they are incorporated into the description of the items themselves in the schedule of items.



2.0 EARTH WORK & SAND FILLING

2.1 General



- 2.1.1 Each dimension upto 25 m shall be measured to nearest 0.01 m and to nearest 0.1 m for dimensions over 25 m. Areas shall be worked out to the nearest 0.01 m² and cubical contents to the nearest 0.01 m³.
- 2.1.2 Shoring and strutting shall not be measured separately unless otherwise specified.
- 2.1.3 Dewatering for earth work and sand filling work shall not be measured separately unless otherwise specified.
- 2.1.4 For classification of soils, relevant clauses of Technical specification (workmanship and other requirements) is to be followed.

2.2 Requirements for particular works

2.2.1 Site levelling

	LAYING, INSTALLATION, TESTING AND COMMISSIONING OF 8” DIA. STEEL GAS PIPELINE CONNECTIVITY IN PATAN GA	
TENDER DOCUMENT NO REPL/SGL/STPL/009/22		Date: -28/11/2022

- 2.2.1.1 For site levelling levels shall be taken jointly before start & after completion of work and the quantity computed based on the levels. Measurements shall be made only for excavation and no separate measurement for filling shall be made except where earth, borrowed from elsewhere for site levelling work, will be measured separately only for that borrowed portion of earth.
- 2.2.1.2 In cases where it is not possible or convenient to take measurements from excavated cuts or borrow pits, excavation shall be worked out from filling based on the levels to be taken before and after completion of works. Deduction of 10 percent will be made for voids, however for consolidated fills done through heavy mechanical means, the deduction for voids shall be 5% in place of 10%.
- 2.2.1.3 In exceptional cases where the quantity is measured on the lorry measurement, loose stacks, boxes or any other similar method with the approval of the Engineer the deduction for voids shall be 20 per cent from the actual quantity.
- 2.2.2 Excavation**
- 2.2.2.1 Before commencing excavation of foundations for buildings and structures, the initial ground levels shall be jointly recorded. The depth of excavation and the calculation of lift shall be based on this. Normally the initial ground level shall be considered as the level of the site as handed over to the contractor. In case excavation is planned and approved to be taken up subsequent to terracing, the terrace level shall be treated as initial ground level.
- 2.2.2.2 Excavation of foundations, trenches, basements, pits etc., shall be measured to the dimensions shown in the excavation plan, if any, or of the lowest concrete or masonry course, as the case may be and the actual depth. Working space and slopes shall not be measured.
- 2.2.2.3 Excavation of rock shall be measured from stacks of excavated rock with a deduction of 50 per cent for voids or measured in the solid based on levels.

	LAYING, INSTALLATION, TESTING AND COMMISSIONING OF 8” DIA. STEEL GAS PIPELINE CONNECTIVITY IN PATAN GA	
TENDER DOCUMENT NO REPL/SGL/STPL/009/22		Date: -28/11/2022

2.2.2.4 In case of following works, no measurement will be recorded for the excavation beyond drawing / specification.

- (a) In work which will be covered externally with damp proof covering.
- (b) In work which requires formwork.
- (c) In work which requires workmen to operate from the outside and for guniting and post tensioned concrete, ground beams etc.

However, if there is a specific provision otherwise in the item/specification/preamble, for authorised working, it shall be measured accordingly. This working space may be 60 cm. measured from the face of the structure at lowest level, unless otherwise mentioned.

2.2.2.5 Surface Dressing

Trimming of natural ground, excavated surface and filled up area to remove vegetation and/or small in equalities not exceeding 15 cm deep shall be described as surface dressing and measured in square metres unless otherwise specified in the schedule of items/ preamble.

2.2.2.6 Lead



The distance for removal shall be measured over the shortest practicable route and not necessarily the route actually taken.

The description of the item shall include loading and unloading.

For the purpose of the measurement of the lead, the area excavated shall be divided in suitable block and for each block the distance from the centre of the block to the centre of the placed earth pertaining to this block shall be taken as lead.

2.2.3 Back filling/filling

2.2.3.1 In foundations, trenches, basements, pits, etc. and in other like areas, the measurements shall be the theoretical volume of the filling computed from

	LAYING, INSTALLATION, TESTING AND COMMISSIONING OF 8” DIA. STEEL GAS PIPELINE CONNECTIVITY IN PATAN GA	
TENDER DOCUMENT NO REPL/SGL/STPL/009/22		Date: -28/11/2022

drawings i.e. the volume measured under excavation minus the volume occupied by the structure and part filling if any, done otherwise.

- 2.2.3.2 In filling under floors the measurements shall be the theoretical volume as per drawings after deducting the part filling if any, done otherwise.
- 2.2.3.3 In embankments, the work shall commence only after recording jointly the initial ground levels and the measurements shall be made on the basis of finished cross section and initial ground levels. Where controlled compaction by mechanical compaction is done, 5% deduction for voids shall be made. In case controlled compaction by mechanical means is not done then deduction for voids shall be 10%.
- 2.2.3.4 Filling/Back filling shall not be measured separately for items of excavation, where filling/back-filling is a part of the composite item and as such is included in excavation item itself.

3.0 ANTI-TERMITE TREATMENT

Measurement shall be the plinth area of the ground floor of the building treated. Dimensions shall be measured to the nearest 0.01 m and area to nearest 0.01 m².



4.0 CONCRETE (PLAIN & REINFORCED)

4.1 Concrete

- 4.1.1 Dimensions shall be measured to nearest 0.01 m except for the thickness of slab, which will be to nearest 0.005 m. Areas shall be worked out to nearest 0.01 m² and cubic contents to nearest 0.01 m³.
- 4.1.2 The concrete shall be measured as per drawings except in the cases of approved variations which will be measured separately.

No deductions shall be made for the following :

- i) Ends of dissimilar materials such as beams, rafters, purlins etc., upto 500 cm² in cross section.

	LAYING, INSTALLATION, TESTING AND COMMISSIONING OF 8” DIA. STEEL GAS PIPELINE CONNECTIVITY IN PATAN GA	
TENDER DOCUMENT NO REPL/SGL/STPL/009/22		Date: -28/11/2022

- ii) Openings upto 0.1 m² in area (In calculating area of an opening, the thickness of any separate lintel or sill shall be included in the height. No extra labour for forming such opening or voids shall be measured).
- iii) Volume occupied by reinforcement or other embedments such as anchors, inserts, conduits or volume occupied by pipes, sheathing etc. not exceeding 100 sq. cm. each in cross sectional area or as specified.
- iv) Small voids not exceeding 40 cm² each in cross section.
- v) Moulds, drip moulding, chamfer, splay, beds, grooves and rebates upto 10 cm in width or 15 cm in girth.



4.13 Columns shall be measured from top of column base to underside of first floor slab and from top of floor to underside of floor slab above thereafter. Beams shall be measured from face to face of columns and will include haunches. Depth of beam shall be measured from bottom of slab and in the case of inverted beams from top of slab. Chajjas and other cantilevers shall be measured from the face of the projection. Where vertical fins are combined with chajja, the latter shall be measured clear between fins. In case chajja is not combined with lintel, beam or slab, it shall be measured inclusive of bearing.

4.2 REINFORCEMENTS

4.2.1 Norms for Steel Consumption

The requirement of mild and high strength deformed bars for various works like reinforcement, guard bars, fan hooks etc. shall be calculated as mentioned below :



- i) As per drawing including
 - (a) Authorised laps, bends, standard hooks and deviations etc.

	LAYING, INSTALLATION, TESTING AND COMMISSIONING OF 8" DIA. STEEL GAS PIPELINE CONNECTIVITY IN PATAN GA	
TENDER DOCUMENT NO REPL/SGL/STPL/009/22		Date: -28/11/2022

(b) Spacer bars, chairs, hangers, supports, spacer blocks dowels etc. are to be considered for wastage only and not to be measured for payment purpose.

- ii) Quantity upto 0.5% of (i) above towards unaccounted wastages, plus
- iii) Quantity upto 3% of (i) above towards cut pieces, which shall be pieces below 2m. length. These cut pieces shall not be taken back even though steel has been issued by the client/owner.

- 4.22 Reinforcements shall be measured in lengths to the nearest 0.01 m for various diameters of bar and converted into weight in tonnes to the nearest kg. on the basis of standard weights as per IS : 1786-1986. No allowance shall be made in the weight for rolling margin.
- 4.23 Authorised laps, standard hooks, bends shall be measured.
- 4.24 Sapacer bars, chairs, hangers, supports, spacer blocks and unauthorised laps etc. shall not be measured unless otherwise specified.
- 4.25 Dowels neither shown on the drawings nor instructed by the Engineer, but required for construction facilities shall not be measured for payment.
- 4.26 Modification of already embedded reinforcement, if required due to faulty fabrication or placement, shall not be measured for payment.
- 4.27 The measurements of reinforcements (including authorised laps, hooks, bends) shall be taken only from Bar bending lists or from the drawings except in the cases of approved variations which will be measured as per 4.2.2.
- 4.28 Wire netting and fabric reinforcement shall be described (including meshes and wire/strands) and measured in square metre, unless otherwise specified in the schedule of item. Authorised laps shall be measured. Raking or circular cutting and waste shall be included in the description of item.

	LAYING, INSTALLATION, TESTING AND COMMISSIONING OF 8” DIA. STEEL GAS PIPELINE CONNECTIVITY IN PATAN GA	
TENDER DOCUMENT NO REPL/SGL/STPL/009/22		Date: -28/11/2022

4.29 Hoop iron shall be fully described and measured in running metres unless otherwise specified in the schedule of item.

4.210 Binding wire for the reinforcement shall not be measured separately and shall be included in the item of reinforcement.

4.3 ADMIXTURE

Admixture will be measured separately as specified or on the basis of the requirement as approved by the Engineer.

4.4 FORMWORK

Each dimension shall be measured to the nearest 0.01 m and area to the nearest 0.01 sq.m.

4.4.1 Formwork shall be measured as the actual surface in contact with concrete and paid in sq.m. unless included in the rate for concrete in specific item of work.

4.4.2 All the measurements shall be computed from the drawings except in the cases of approved variations which will be measured separately.



4.4.3 Formwork shall not be measured separately for precast concrete work, grouting and damp proof course which shall be included in the concrete rates.

4.4.4 No measurement for formwork in construction joints shall be made.

4.4.5 Openings upto 0.1 sq.m. shall be neglected, as if non - existent, for the purpose of formwork measurement.

4.4.6 No extra measurement or payment shall be made for making the form work water proof or for supports, scaffolding, staging, centering, approaches etc.

4.4.7 No measurement shall be taken for the formwork in pockets, openings, chambers, chases etc., in concrete if the cross sectional area is less than or

	LAYING, INSTALLATION, TESTING AND COMMISSIONING OF 8” DIA. STEEL GAS PIPELINE CONNECTIVITY IN PATAN GA	
TENDER DOCUMENT NO REPL/SGL/STPL/009/22		Date: -28/11/2022

equal to 0.1 sq.m. in each case. If the cross section area of any opening exceeds 0.1 sq.m. the actual area of the formwork shall be measured for payment.



4.5 EMBEDDED PARTS

- 4.5.1 These shall be measured on the basis of standard theoretical weight of the complete insert according to the drawing/direction.
- 4.5.2 Embedded steel, which are the integral parts of the embedment according to drawing and are required for anchoring the embedded parts in concrete shall be measured on the basis of the theoretical standard weight. In case of anchor bolts the theoretical weights of the nuts, lock nuts, check nuts and washers shall be added in the measurement for payment.
- 4.5.3 All bye-works such as jigs, fixtures, templates and other arrangements which are not integral parts of the embedded parts, but necessary to secure those (embedded parts) in position shall not be measured for payment.
- 4.5.4 Anti-corrosive paint over the exposed surfaces and protection of the anchor bolts with grease tc., shall not be measured for payment.
- 4.5.5 Modification works necessary to rectify the mistake of already placed embedded parts shall not be measured.

4.6 GROUTING

- 4.6.1 Grouting shall be measured in volume except in the cases of grouting by special cement compound or epoxy compound which will be measured by number.
- 4.6.2 Measurement shall be computed from the drawings except in the cases of approved variations which shall be measured separately and subsequently added to or deducted from.
- 4.6.3 Necessary formwork shall not be measured for payment.

4.7 DAMP PROOF COARSE

	LAYING, INSTALLATION, TESTING AND COMMISSIONING OF 8" DIA. STEEL GAS PIPELINE CONNECTIVITY IN PATAN GA	
TENDER DOCUMENT NO REPL/SGL/STPL/009/22		Date: -28/11/2022

4.7.1 Measurement shall be in sq.m. stating thickness and computed from the drawings except in the cases of approved variations which will be measured separately.

4.7.2 Necessary formwork shall not be measured for payment.

5.0 MASONRY

5.1 Dimensions shall be measured to nearest 0.01 m, areas to nearest 0.01 m² and cubic contents to nearest 0.01 m³.



5.2 No deduction shall be made for :

- (i) Ends of dissimilar materials such as joints, beams, posts, girders, trusses, lintels, purlins etc., upto 0.1 m² in section.
- ii) Openings upto 0.1 m² in area.
- (iii) Wall plates, bed plates, bearing of slab etc., thickness not exceeding 10 cm. and bearing not extending over the full thickness of wall.
- (iv) Cement concrete blocks for holdfasts and the like.
- (v) Iron fixtures such as pipes etc. upto 300 mm. dia. and hold fasts for doors and windows.

5.3 Dressed stonework such as in sills, cornices , column caps, copings etc., shall be measured as the smallest rectangular block from which the finished stone can be worked.

5.4 Honeycomb openings shall not be deducted from the area of honeycomb brickwork.

5.5 Brickwork of full brick width or more shall be measured in cu.m. while of thickness of half brick or less shall be measured in sq.m., unless otherwise specified.

	LAYING, INSTALLATION, TESTING AND COMMISSIONING OF 8” DIA. STEEL GAS PIPELINE CONNECTIVITY IN PATAN GA	
TENDER DOCUMENT NO REPL/SGL/STPL/009/22		Date: -28/11/2022

5.6 Reinforcements for reinforced brick work shall be measured separately, unless otherwise specified and no deduction for reinforcement shall be made from brickwork.

6.0 PLASTERING & POINTING

6.1 All plastering and pointing shall be measured in sq.m. unless otherwise described. Dimensions shall be measured to nearest 0.01 m and areas to 0.1 sq.m.

6.2 Ceiling shall be measured between walls or partitions (dimensions before plastering) shall be taken. Measurement of wall plastering shall be taken between walls or partitions for length (dimension before plastering) and from top of floor or skirting to ceiling for height.

6.3 The methods of measurement including the deductions for openings etc., shall be according to the relevant part of IS : 1200 (Part 1 to 28) - 1971 to 1993.



7.0 WHITE WASHING, COLOUR WASHING, PAINTING & OTHER FINISHES.

The method of measurement shall be according to the relevant part of IS : 1200 (Part 13 & 15) - 1987.

8.0 FLOORING, PAVING & FACING WORKS

8.1 The work shall be measured as a complete finished item including necessary underbed, adhesives, dividing strips, joint sealing and necessary grinding, polishing and finishing where specified. The subgrade or the base course shall be measured separately against respective item unless otherwise specified.

8.2 All works shall be measured net, dimensions being measured to nearest 0.01 m and areas to nearest 0.01 sq.m. Any opening less than 0.1 sq.m. in area shall not be deducted nor any extra payment made for that.

	LAYING, INSTALLATION, TESTING AND COMMISSIONING OF 8” DIA. STEEL GAS PIPELINE CONNECTIVITY IN PATAN GA	
TENDER DOCUMENT NO REPL/SGL/STPL/009/22		Date: -28/11/2022

8.3 Building paper or water proofing by bituminous felts/mastic asphalt treatment, where specified to be laid below floor, shall be measured separately for payment unless otherwise specified.

8.4 Laps and seams in sheet finishing (linoleum, cork, PVC, rubber & like) shall be deemed to be included in the item itself even if not described explicitly and shall not be measured and paid separately.

9.0 WOODWORK

9.1 All work shall be measured net for finished dimensions as fixed, that is no extra measurement or allowance shall be made for shape, joints, wastage etc. subject to specific provision made in the IS : 1200 (Part 21) - 1973 and for dimensions supplied beyond those specified in the drawing.

9.2 Wooden frame

rough, finished and fixed shall be measured net for overall length nearest to 0.01 m, width and thickness to the nearest 2mm or as specified in the drawing and cubic contents calculated in cubic metres to the nearest three places of decimals.

Wooden shutters of all types



Length and width of the shutters shall be measured net as fixed to the nearest cm. in closed position covering the rebates of the frame but excluding the gap between the shutter and the floor and the area calculated in square metre upto two places of decimal.

Over lap of two leaves of shutter shall not be measured separately.



Hand rails

Hand rails of finished width and depth as specified in the item shall be measured in running metres upto two places of decimal.

9.3 Painting and polishing, unless otherwise described in the schedule of items, shall be measured separately for payment.

	LAYING, INSTALLATION, TESTING AND COMMISSIONING OF 8” DIA. STEEL GAS PIPELINE CONNECTIVITY IN PATAN GA	
TENDER DOCUMENT NO REPL/SGL/STPL/009/22		Date: -28/11/2022

- 9.4** Builder's hardware and fittings for doors windows and ventilators shall be measured separately, unless stated otherwise in the Schedule of Items. Hardware and fittings shall be measured according to IS : 1200 (Part-VII) - 1972.
- 9.5** Hold fasts for door, window and ventilator frames shall be measured separately.
- 9.6** **Timber Partitions**
- This shall be measured in area calculated in sq. m. to the nearest two places of decimal.
- 9.7** **Glazed shutters and glazed partitions (Wooden)**
- Glazed shutters/glazed partitions with wooden frames shall be measured as a single item in area calculated in sq.m. to the nearest two places of decimal. No separate measurement for glazing/glass panes shall be made.
- 9.8** Provision of making holes/opening/chases in masonry/ concrete flooring etc. for fixing and making good of the same shall not be measured separately for payment.
- 9.9** Bitumen painting or approved wood preservative of the timber surfaces in contact with masonry/concrete floor etc. shall not be measured for payment.
- 10.0** **METAL DOORS, WINDOWS & VENTILATORS**
- 10.1** Door, window and ventilator/louvers as fixed, shall be measured net as clear width between jambs and clear height between floor/sill and underside of lintel, but excluding the gap between door shutters and floor. Dimensions shall be calculated to the nearest 0.01 m., area calculated in sq.m. upto two places of decimal.
- 10.2** For MS collapsible shutter/gate, rolling shutter sliding folding door, length and breadth shall be measured to the nearest cm. for the clear area of

	LAYING, INSTALLATION, TESTING AND COMMISSIONING OF 8” DIA. STEEL GAS PIPELINE CONNECTIVITY IN PATAN GA	
TENDER DOCUMENT NO REPL/SGL/STPL/009/22		Date: -28/11/2022

opening as per drawing in which they are installed and calculated in sq.m. to the nearest two places of decimal.

10.3 M.S. Rolling grills, doors of steel plate, sliding door louvered ventilators, gates, grills, as fixed, shall be measured and computed to weight from the size as per drawing unless otherwise specified.

10.4 Glazed doors, windows, louvers, partitions (both steel and aluminium) shall be measured in sq.m. to the nearest two places of decimal. No separate measurement for glazing/glass panes shall be made for payment.

11.0 GLAZING

11.1 Glazing shall not be separately measured for doors, windows and ventilators unless otherwise specified.



11.2 North light and roof glazing shall be paid as the area from outside to outside of glazing including frames, to the nearest 0.01 sq.m.

11.3 Glazing, where shown in the schedule of items as a separate item, shall be measured from edge to edge of glass as fixed.



12.0 WATER SUPPLY, DRAINAGE, SEWERAGE & SANITATIONS

12.1 All the pipelines buried under soil/masonry/floors/ concrete, laid over/underground/along masonry/along under floor shall be measured in metres along the centreline together with fittings/specials upto two places of decimal against respective schedule of items for different diameter (the diameter as specified shall mean nominal bore except PVC pipe) unless otherwise specified.

12.2 All necessary earth work in trenches for laying pipe lines including dewatering, levelling and trimming to the gradient, sand filling in the trenches before laying the pipe, back filling either by sand or by approved borrowed soil after laying the pipe lines including necessary compaction by spraying water and levelling/dressing the same shall not be measured separately for payment unless otherwise specified.

	LAYING, INSTALLATION, TESTING AND COMMISSIONING OF 8” DIA. STEEL GAS PIPELINE CONNECTIVITY IN PATAN GA	
TENDER DOCUMENT NO REPL/SGL/STPL/009/22		Date: -28/11/2022

- 12.3** All required specials, i.e. bends tees, shoes cowls, plug, elbows, unions, caps, checkout and the like excluding valves shall not be measured separately for payment unless otherwise specified.
- 12.4** All fixing and supporting arrangement of the pipes like the supports, saddles, brackets, clamps, cleats, covering the pipes with concrete in case of pipes laid over ground, special arrangement for supporting the pipe like while coming out from the building to the trenches etc. shall not be measured separately for payment, unless otherwise specified.
- 12.5** All the arrangement in road crossing like cutting the road, diverting the road and drains, concealing the pipes with suitable approved measures, backfilling the area, covering and making good of the road with similar materials/design shall not be measured separately for payment, unless otherwise specified.
- 12.6** Septic tanks, inspection pits, manholes etc., shall be considered as a composite single item including excavation, dewatering, concrete, masonry, back filling, protection of other service lines and all the like works unless otherwise specified.
- 12.7** All the valves and all the bathroom/W.C./Kitchen fixtures like bib tap, stop cock, shower, all sanitary wares, towel rails, mirrors etc., shall be measured separately under respective item in the schedule, unless otherwise specified.
- 13.0 WATER PROOFING, DAMP PROOFING**
- 13.1 Water proofing for roofs**
- 13.1.1 Length and breadth shall be measured in metre upto two places of decimal and area calculated in sq.m. upto two places of decimal.
- 13.1.2 Measurement shall be made for the net covered area. No measurement shall be made for overlapping for end and side joints and for bends around/along the corners, ends and for special treatment around pipes, rain water gulleys, steel structure and the like etc. No deduction shall be made

	LAYING, INSTALLATION, TESTING AND COMMISSIONING OF 8” DIA. STEEL GAS PIPELINE CONNECTIVITY IN PATAN GA	
TENDER DOCUMENT NO REPL/SGL/STPL/009/22		Date: -28/11/2022

in the measurement for the opening of area less than 0.1 m² each and no extra payment shall also be made for any special works made around such openings.

13.1.3 Water proofing treatment shall be considered as a single composite item including priming painting coat, water proofing felts, binding bituminous coats, top bituminous coat and pea size gravel or sand finishing etc.

13.1.4 For lime concrete terracing the consolidated thickness shall be considered for measurement.

13.2 For Water proofing treatment in basement

13.2.1 With bituminous felts

1321.1 Length and breadth shall be measured in metre upto two places of decimal and area calculated in sq.m. utp two places of decimal.



1321.2 Measurement shall be made for the net covered area. Measurement shall be made from the drawing, except in certain special cases where it is impossible to compute from drawing and the measurement shall be made as executed. No measurement shall be made for overlaps, special measures around projected pipes, sealing the bends/rounds and in other cases, necessary projection/ overlap for the connection between vertical and horizontal junction etc.

1321.3 Water proofing treatment shall be considered as a single composite item, including priming painting coat, water proofing felts, binding bituminous coats and top bituminous coat etc.

13.3 Mastic Treatment

13.3.1 Length and breadth shall be measured in metres upto two places of decimal and area calculated in sq.m. upto two places of decimal.

13.3.2 Measurement shall be made for the net covered area. No deduction in measurement shall be made for opening of area upto 0.1 sq.m. each and no extra payment shall be made for any special treatment around such

	LAYING, INSTALLATION, TESTING AND COMMISSIONING OF 8” DIA. STEEL GAS PIPELINE CONNECTIVITY IN PATAN GA	
TENDER DOCUMENT NO REPL/SGL/STPL/009/22		Date: -28/11/2022



openings. No measurement shall be made for extra payment for the special works necessary for junctions, corners, roundings, bends for the works around pipes and the like.

14.0 CEILING & LININGS

- 14.1 Dimensions shall be measured to the nearest 0.01 m., areas to be worked out to the nearest 0.01 sq.m.
- 14.2 Work formed to circular surfaces shall be measured separately unless otherwise specified.
- 14.3 All work unless otherwise described shall be measured as flat in sq.m.
- 14.4 No deduction in measurement shall be made for openings not exceeding 0.4 sq.m. and no extra measurement shall be made for forming such openings.



15.0 ROAD WORK

- 15.1 Dimensions shall be measured to nearest 0.01 m. Where the thickness is less than 20 cm., it shall be measured to nearest 0.005 m. Areas shall be worked out to nearest 0.01 sq.m. and cubic contents to the nearest 0.01 cu.m.
- 15.2 Where thickness is measured, it shall be the minimum thickness after compaction.
- 15.3 Cement concrete bases and roads shall be measured either in sq.m. or cu.m. as specified.
- 15.4 Unless otherwise specified, expansion and dummy joints shall be described and measured separately and given in running metres stating the thickness and depth of the joints.

	LAYING, INSTALLATION, TESTING AND COMMISSIONING OF 8" DIA. STEEL GAS PIPELINE CONNECTIVITY IN PATAN GA	
TENDER DOCUMENT NO REPL/SGL/STPL/009/22		Date: -28/12/2021

SPECIFICATION FOR CIVIL WORKS

PART – VI SAFETY REQUIREMENTS FOR CONSTRUCTION WORKS

	LAYING, INSTALLATION, TESTING AND COMMISSIONING OF 8" DIA. STEEL GAS PIPELINE CONNECTIVITY IN PATAN GA	
TENDER DOCUMENT NO REPL/SGL/STPL/009/22		Date: -28/12/2021

1.0 GENERAL



This specification deals with the subject matter of safety and protection to be observed in the Civil Construction. This shall be followed along with all related statutory requirements/obligation including Governmental byelaws, codes, ordinance of local or central authorities related to the construction work.

In case of complicated work like deep excavation, intricate shuttering and formwork, excavation in loose soil and below water table, stacking of excavated earth etc., work plan with necessary drawings and documents have to be prepared by the Contractor and got approved by the Engineer.

Necessary reference shall be made to the following Indian Standard Codes on safety requirements for various type of work :

Indian Standard

4081 - 1986	Blasting & Drilling.
5916 - 1970	Construction with Hot Bituminous Materials.
4130 - 1991	Demolition of Buildings.
3764 - 1992	Excavation Work
5121 - 1969	Piling & Other Deep Foundations.
4014 - (P-II) - 1967	Scaffolding, Steel Tubular.
3696 - (P-I & P-II)	Scaffolds and Ladders.
1987 to 1991	
6922 - 1973	Structures Subject to Underground Blasts.
4756 - 1978	Tunneling Work.
5499 - 1969	Underground Air-raid Shelters in Natural Soil.



	LAYING, INSTALLATION, TESTING AND COMMISSIONING OF 8” DIA. STEEL GAS PIPELINE CONNECTIVITY IN PATAN GA	
TENDER DOCUMENT NO REPL/SGL/STPL/009/22		Date: -28/11/2022

- 4138 - 1977 Working in Compressed Air.
- 7293 - 1974 Working with Construction Machinery
- 8989 - 1978 Erection of Concrete Framed Structures.



2.0 BLASTING

- 2.1 Detonators and other explosive for blasting shall be taken to the blasting area in the original container or any separate non-metal container. This shall not be carried loose or mixed with other materials. Detonators and explosives must be kept separately.
- 2.2 No shot for blasting shall be fired except by persons licensed to do so.
- 2.3 Drilling shall not be resumed after a blast has been fired unless a thorough examination has been made to make sure that there is no unexploded charge.
- 2.4 Before firing a shot, sufficient warnings by means of whistling and/or otherwise shall be given to get men off the danger area. Blasting areas shall be cordoned off & red flags during day time and red lights during night time displayed prominently marking off the cordoned area.
- 2.5 All people except those who have actually to light the fuses must be removed to a safe distance of not less than 200 metres as a rule.
- 2.6 Wherever possible, blasting mats should be used.
- 2.7 Contractors doing blasting work must have licence and an approved magazine to store explosives.
- 2.8 Blasting operations shall be carried out during fixed hours of the day which shall be notified in writing.
- 2.9 Provisions in explosives Rules 1940 as amended from time to time, Indian Explosives Act 1844 (IV of 1884), and others shall be strictly followed.

3.0 EXCAVATIONS

	LAYING, INSTALLATION, TESTING AND COMMISSIONING OF 8” DIA. STEEL GAS PIPELINE CONNECTIVITY IN PATAN GA	
TENDER DOCUMENT NO REPL/SGL/STPL/009/22		Date: -28/11/2022

- 3.1 Sides of all excavations must be sloped to a safe angle, not steeper than the angle of repose of the particular soil. If it is not possible to give a proper slope, the sides of the excavation where there is a danger of fall or dislodgement of earth or any material, shall be securely supported by timber or other type of shoring.
- 3.2 No excavation or earth work below the foundation level of an adjoining building shall be taken up unless adequate steps are taken to prevent damage to the existing structure or fall of any part.
- 3.3 Every accessible part of an excavation, pit or opening in the ground into which there is a danger of persons falling shall be suitably fenced with a barrier upto a height of one metre suitably placed from the edge of the excavation as far as practicable.
- 3.4 No material or load shall be placed or stacked near the edge of the excavation or opening in the ground. The excavated material shall not be placed within 1.5 m of the trench or half of the depth of the trench whichever is more.
- 3.5 Cutting shall be done from top to bottom. No undercutting of sides of excavation shall be allowed.
- 3.6 All narrow trenches 1.2 m or more depth, shall at all times be supplied with atleast one ladder for each 30m in length or fraction thereof. Ladder shall be extended from bottom of the trench to atleast one metre above the surface of the ground. The side of the trenches which are 1.5 m or more in depth shall be stepped back to give suitable slope, or securely held by planking, strutting and bracing so as to avoid the danger of side collapse.
- 3.7 Materials shall not be dumped against existing walls or partition to a height that may endanger the stability of the walls.
- 3.8 While withdrawing piled materials like loose earth, crushed stone, sand, etc., from the stock piles, no over hanging shall be allowed to be formed in the existing dump.

	LAYING, INSTALLATION, TESTING AND COMMISSIONING OF 8” DIA. STEEL GAS PIPELINE CONNECTIVITY IN PATAN GA	
TENDER DOCUMENT NO REPL/SGL/STPL/009/22		Date: -28/11/2022

3.9 No material on any of the sites of work shall be so stacked or placed as to cause danger or inconvenience to any person or public or any other agency at work.

4.0 DEMOLITION

4.1 On every demolition job, danger signs shall be conspicuously posted all round the structure and all doors, openings giving access to the structure shall be kept barricaded or marked except during the actual passage of workmen or equipment. However, provision shall be made for at least two independent exits for escape of workmen during any emergency.



4.2 During night, red lights shall be placed on or about all the barricades.

4.3 Where in any work of demolition it is imperative, because of danger existing to ensure that no unauthorised person shall enter the site of demolition outside working hours, a watchman should be employed. In addition to watching the site he shall also be responsible for maintaining all notices, lights and barricades.



4.4 All the necessary safety appliances as per IS ;4130 shall be issued to the workers and their use explained. It shall be ensured that the workers are using all the safety appliances while at work.

4.5 The removal of a member may weaken the side wall of an adjoining structure and to prevent possible damage, these walls shall be supported until such time as permanent protection is provided. In case any danger is anticipated to the adjoining structure the same shall be got vacated to avoid any danger to human life.

4.6 The power on all electrical service lines shall be shut off and all such lines cut or disconnected at or outside the property line, before the demolition work is started. Prior to cutting of such lines the necessary approval shall be obtained from the electrical authorities concerned. The only exception will be any power line required for demolition work itself.

	LAYING, INSTALLATION, TESTING AND COMMISSIONING OF 8” DIA. STEEL GAS PIPELINE CONNECTIVITY IN PATAN GA	
TENDER DOCUMENT NO REPL/SGL/STPL/009/22		Date: -28/11/2022



- 4.7** All gas, water, steam and other service lines shall be shut off and capped or otherwise controlled at or outside the building line, before demolition work is started.
- 4.8** All the mains and meters of the building shall be removed or protected from damage.
- 4.9** If a structure to be demolished has been partially wrecked by fire, explosion or other catastrophe, the walls and damaged roofs shall be shored or braced suitably.
- 4.10** Walkways and passage ways shall be provided for the use of the workman who shall be instructed to use them and all such walkways and passageways shall be kept adequately lighted, free from debris and other materials.
- 4.11** All nails in any kind of lumber shall be withdrawn, hammered or bent over as soon as such lumber is removed from the structure being demolished, and placed in piles for future cleaning or burning.
- 4.12** All the roads and open area adjacent to the work site shall either be closed or suitably protected.
- 4.13** No electric cable or apparatus which is liable to be a source of danger or a cable or apparatus used by the operator shall remain electricity charged.
- 4.14** All practical steps shall be taken to prevent danger to persons employed from risk of fire or explosion or flooding. No floor, roof or other part of the building shall be so overloaded with debris or materials as to render it unsafe.
- 5.0 VEHICLE**
- 5.1** No person shall board any vehicle or equipment when it is in motion.
- 5.2** Suitable blocks shall be placed against the wheels of a vehicle when it is used for tipping materials into excavation or a pit or over the edge of any embankment or earthwork to avoid the danger of its running over the edge.

	LAYING, INSTALLATION, TESTING AND COMMISSIONING OF 8” DIA. STEEL GAS PIPELINE CONNECTIVITY IN PATAN GA	
TENDER DOCUMENT NO REPL/SGL/STPL/009/22		Date: -28/11/2022



- 5.3 All workers shall stand clear of the vehicle while it is dumping. If the material being dumped is very heavy or sticky, dump hooks shall be used or dumper shall be clamped to prevent any danger of its tripping.
- 5.4 Materials shall not be allowed to be loaded in a vehicle so as to project horizontally beyond the sides of the body of the vehicle. All materials projecting beyond the front or rear shall be indicated by a red flag in the day and with red light in the night.
- 5.5 Driver of the truck or any heavy vehicle shall not reverse it unless assisted by a signal man who shall have a clear view of the driver and the area beyond the truck during reversing operation.
- 5.6 Maximum speed of a heavy vehicle must not exceed 15 km. per hour.

6.0 **SCAFFOLDING, GANGWAYS, LADDERS & SHUTTERING**

- 6.1 For all work that cannot be done from the ground level or from part of any permanent structure or from other available means of support, soundly constructed scaffoldings of adequate strength shall be used as a safe means of access to places of work.
- 6.2 All scaffolding shall be securely supported or suspended and wherever necessary be properly braced to ensure stability.
- 6.3 Chains, ropes or other lifting materials used for the suspension of scaffoldings must be of adequate strength and shall be of tested quality.
- 6.4 All such chains and ropes used for the suspension of scaffoldings shall be properly fastened to safe anchorage points.
- 6.5 The platform of a suspended scaffolding shall be sufficiently wide. Suspended scaffolding shall have hand rail on 3 sides of about 1.0 m height.
- 6.6 All working platform and stages from which workers are liable to fall shall be of adequate width depending on the type of work done and closely boarded and planked.



	LAYING, INSTALLATION, TESTING AND COMMISSIONING OF 8” DIA. STEEL GAS PIPELINE CONNECTIVITY IN PATAN GA	
TENDER DOCUMENT NO REPL/SGL/STPL/009/22		Date: -28/11/2022

- 6.7** Scaffolding or staging more than 3.5 m above the ground or floor, suspended from an overhead support or erected with stationary support shall have a guard rail properly attached, bolted, braced and otherwise secured atleast 1 m high above the floor or platform of such scaffolding or staging and extending along the entire length of the outside ends thereof with only such opening as may be necessary for the delivery of materials. Such scaffolding or staging shall be so fastened as to prevent it from swaying from the building or structure. The platform shall also be provided with toe boards of atleast 150 mm high so placed as to prevent the fall of materials and tools from there.
- 6.8** All platforms or gangways, runways and the stairs shall be kept free from unnecessary obstructions, materials or junk.
- 6.9** Working platforms, gangways & stairways shall be so constructed that they shall not sag unduly or unequally, and if the height of the platform or the gangway or the stairway is more than 3.5 m above ground level or floor level they shall be closely boarded, shall be of adequate width and shall be suitably fenced.
- 6.10** Every opening in the floor of a building or in a working platform shall be provided with suitable fencing or railing whose minimum height shall be 1 m to prevent the fall of persons or materials.
- 6.11** Every ladder shall be securely fixed at top and bottom. A ladder more than 5 m long shall have a prop.
- 6.12** All ladders used shall be of good construction, sound materials and adequate strength. Ladders with defective or missing rungs shall not be brought into use. The spacing of rungs shall not exceed 30 cms and these shall be recessed atleast 12 mm into rails.
- 6.13** All ladders or rungs used for vertical height of more than 10 m shall have an intermediate landing. All such intermediate landings shall be provided with guard rails to a height of atleast 1 m.
- 6.14** Every ladder shall be securely placed so that it cannot move either at the top or at the bottom and it shall rise to a height of atleast 1.2 m above the

	LAYING, INSTALLATION, TESTING AND COMMISSIONING OF 8” DIA. STEEL GAS PIPELINE CONNECTIVITY IN PATAN GA	
TENDER DOCUMENT NO REPL/SGL/STPL/009/22		Date: -28/11/2022



place of landing.

- 6.15** No portable single ladder shall be over 8 m in length.
- 6.16** Spacing between the side rails of the ladder shall not be less than 300 mm for ladders upto 3 m in length. For longer lengths, this shall be increased at 6 mm for each additional 0.3 m of length.
- 6.17** Metal ladders must not be used for electrical work or near electric circuit of equipments.
- 6.18** All scaffolds, ladders and other safety devices mentioned or described herein shall be maintained in safe condition and no scaffold, ladder or equipment shall be altered or removed while it is in use.
- 6.19** Unfinished scaffolding which is under construction shall be prominently marked as unsafe and any access points shall be closed.
- 6.20** All Planking and Decking on walkways and scaffolds should be adequately supported at each end of the plank and intermediately if necessary. Planks should not be allowed to cantilever beyond the last support but should be overlapped if necessary on to the next plant.
- 6.21** **Shuttering**
- The above remarks shall be applicable for this also. Shuttering, particularly for slabs, should be treated as a scaffold. Unfinished shuttering should be marked as dangerous similarly the finished formwork should be adequately supported, care being taken to avoid trap door effects.
- 7.0** **MOBILE LIFTING APPLIANCES**
- 7.1** No mobile lifting appliances shall used on a sloping surface unless adequate precautions are taken to ensure stability.
- 7.2** Adequate precautions shall be taken to see that jib of the mobile crane does not come in contact with overhead electric transmission line.

	LAYING, INSTALLATION, TESTING AND COMMISSIONING OF 8” DIA. STEEL GAS PIPELINE CONNECTIVITY IN PATAN GA	
TENDER DOCUMENT NO REPL/SGL/STPL/009/22		Date: -28/11/2022



- 7.3 Only one person shall give signals to the operator of mobile lifting appliances.
- 7.4 Maximum load to be lifted by lifting appliances shall be marked in a position where it can be clearly seen by the crane driver and the operator.
- 7.5 No load shall be raised, lowered or suspended from a chain or rope having a knot in any of the part.
- 7.6 No chain which is joined to another chain by means of bolt and nut shall be used for raising, lowering or suspending any load.
- 7.7 All chains, ropes and lifting gears shall be carefully examined and tested by a competent Maintenance Engineer atleast once in every quarter.
- 7.8 When the work is stopped or when the mobile lifting equipment is not in operation, the boom must be lowered to the horizontal position and tied securely in place to prevent accidental drop.
- 7.9 No person shall walk under a load which is swinging by a lifting equipment.

Guide rope must be attached to the load to prevent its swinging.
- 7.10 The foot blocks of the crane before starting work shall be securely supported and firmly anchored to prevent its movement in any direction.
- 7.11 Use of Hoisting machines and tackle including their attachments, anchorage and supports shall conform to the following standards of condition.
 - 7.11.1 These shall be of good mechanical construction, sound material and adequate strength and free from defect and shall be kept in good working order.
 - 7.11.2 Every rope used in hoisting or lowering materials or as a means of suspension shall be of durable quality and adequate strength and free from patent defects.
 - 7.11.3 Every crane driver or hoisting appliance operator shall be properly

	LAYING, INSTALLATION, TESTING AND COMMISSIONING OF 8” DIA. STEEL GAS PIPELINE CONNECTIVITY IN PATAN GA	
TENDER DOCUMENT NO REPL/SGL/STPL/009/22		Date: -28/11/2022

qualified and no person under the age of 21 years shall be in charge of any hoisting machine or give signals to the operator.



- 7.11.4 In case of every hoisting machine and every chain ring hook shackle swivel and pulley block used in hoisting or lowering or as means of suspension the safe working load shall be ascertained by adequate means, every hoisting machine and all gears referred to above shall be plainly marked with the safe working load. In case of hoisting machine having a variable safe working loading, each safe working load of the conditions under which it is applicable shall be clearly indicated. No part of any machine or of any gear referred to above in this paragraph shall be loaded beyond the safe working load except for the purpose of testing. Mobile cranes shall have the working load and the radius of jib for the load marked on it.
- 7.11.5 The top pulley for hoisting a load shall be opened monthly and the spindle inspected to see if any undue wear has taken place and for greasing.
- 7.11.6 In case of departmental machine, the safe working load shall be notified by the Engineer concerned. As regards contractor's machines the Contractor shall notify the safe working load of the machine to the Engineer whenever he brings any machinery to site of work and get it verified by the Engineer concerned.
- 7.12** Motors, gearing, transmission, electric wiring and other dangerous part of hoisting appliances shall be provided with efficient safeguards. Hoisting appliances shall be provided with such means as will reduce to the minimum, the risk of accidental descent of the load. Adequate precautions shall be taken to reduce to the minimum, risk of any part of a suspended load becoming accidentally displaced.
- 8.0 RIVETTING, WELDING & GAS CUTTING & STEEL ERECTION**
- 8.1 Rivetting**
- 8.1.1 Bolts covered with wet or slippery compounds shall not be used in fabricating structural work.

	LAYING, INSTALLATION, TESTING AND COMMISSIONING OF 8” DIA. STEEL GAS PIPELINE CONNECTIVITY IN PATAN GA	
TENDER DOCUMENT NO REPL/SGL/STPL/009/22		Date: -28/11/2022

- 8.1.2 The rivet heater must keep the rivet heating equipment as near as possible to the place of work.
- 8.1.3 A pail of water shall always be kept ready for quenching fire when stopping rivetting work.
- 8.1.4 Hot rivet shall not be thrown across aisles and shaftways.
- 8.1.5 Metal buckets for catching hot rivets must have false wooden bottoms to prevent rivets from rebounding.
- 8.1.6 All rivets, bolts, nuts, and other tools must be kept in boxes and not left loose, (For any further safety measures relevant Indian Standards and safety specifications of structural section shall be referred to).

8.2 Welding & Gas Cutting



- 8.2.1 All cylinders must be used and stored in upright position only.
- 8.2.2 Cylinders must be stored away from open flames and other source of heat.
- 8.2.3 Oxygen cylinders must not be stored near other cylinders containing gas or oil, grease or other combustible materials.
- 8.2.4 While the cylinder is in use, the cylinder valve key or wrench must be placed on the valve spindle.
- 8.2.5 Before a cylinder is moved, the cylinder valve must be closed.
- 8.2.6 Gas cutting torches must be lighted by means of friction flames or similar other methods and not with matches.
- 8.2.7 When torches are being changed or welding stopped for some time valves for all cylinders must be closed.
- 8.2.8 The coloured lenses used for welding or gas cutting must be of proper shade for the work being done.

	LAYING, INSTALLATION, TESTING AND COMMISSIONING OF 8” DIA. STEEL GAS PIPELINE CONNECTIVITY IN PATAN GA	
TENDER DOCUMENT NO REPL/SGL/STPL/009/22		Date: -28/11/2022

- 8.2.9 Suitable eye protection equipment such as goggles, hand shields etc., must be used by persons engaged in welding or gas cutting operations.
- 8.2.10 Before any heavy structural member is gas cut, make sure that it is cleared and supported by ropes, cables, chains or any other means to prevent its dropping or swinging.
- 8.2.11 Cylinder valves and connections are not to be lubricated. All oily or greasy substances must be kept away from cylinders.
- 8.2.12 Substantial and incombustible screen must be used below or near the welding operations, if there is a possibility of a spark falling on other workmen engaged in work closely.
- 8.2.13 All air pipe lines and air hoses must be frequently inspected. Air hoses shall not be used for dusting or for cooling purposes.
- 8.3 Steel Erection**
- 8.3.1 All persons shall stand clear when a crane is sorting or shifting steel girders or other structural materials.
- 8.3.2 No person shall stand, walk or work beneath any suspended load.
- 8.3.3 Guide rope must be used for guiding lifting loads.
- 8.3.4 When guiding a beam or fabricated structure or erection it shall be so held that the employees’ hands do not get jammed against other objects.
- 8.3.5 Safety belts equipped with suitable life lines must be used by persons working at heights and standing on structural members. Life line must be tied to an independent support. For any further safety measures, for Structural Steel Works, IS: 7205 - 1974 shall be referred to.



9.0 SAFETY APPLIANCES

- 9.1 Workers employed on mixing asphaltic materials, cement and lime

	LAYING, INSTALLATION, TESTING AND COMMISSIONING OF 8” DIA. STEEL GAS PIPELINE CONNECTIVITY IN PATAN GA	
TENDER DOCUMENT NO REPL/SGL/STPL/009/22		Date: -28/11/2022



mortars, shall be provided with protective footwear and protective goggles.

- 9.2** Those engaged in white washing and mixing or stacking of cement bags or any materials which is injurious to the eyes, shall be provided with protective goggles.
- 9.3** Those engaged in welding works shall be provided with welder's protective eye-shields.
- 9.4** Stone breakers shall be provided with protective goggles and protective clothing and seated at sufficiently safe intervals.
- 9.5** When workers are employed in sewers and manholes which are in use, the Contractor shall ensure that the manhole covers are opened and chambers are ventilated atleast for an hour before the workers are allowed to get into the manholes, and the manholes so opened shall be cordoned off with suitable railing and provided with warning signals or boards to prevent accident to the public.
- 9.6** The Contractor shall not employ men below the age of 18 and women on the work of painting with products containing lead in any form. Whenever men above the age of 18 are employed on the work of lead painting the following precautions shall be taken:
 - 9.6.1** No paint containing lead or lead products shall be used except in the form of paste or ready-made paint.
 - 9.6.2** Suitable face mask should be supplied for use by them when paint is applied in the form of spray on a surface having lead paint dry rubbed and scraped.
 - 9.6.3** Overalls shall be supplied by the Contractors to the workmen and adequate facilities shall be provided to enable the working painters to wash during the cessation of work.
- 9.7** The workers going into inspection chamber shall have gas masks, gum boots and rubber gloves while working inside. After coming out they shall have some disinfectant from the first aid box for proper washing
- 9.8** All necessary personnel safety equipment such as safety helmets, safety

	LAYING, INSTALLATION, TESTING AND COMMISSIONING OF 8” DIA. STEEL GAS PIPELINE CONNECTIVITY IN PATAN GA	
TENDER DOCUMENT NO REPL/SGL/STPL/009/22		Date: -28/11/2022

boots, safety belts, leather gloves for welders, clear glass safety goggles etc., as considered adequate by the engineer have to be kept available for the use of persons employed at the site of work and maintained in condition suitable for immediate use and Contractor shall take steps to ensure proper use of equipment by the workers.

- 9.9** All the persons entering the tunnel shall be provided with protective wear, such as helmets, steel toe safety shoe, gum boots or other suitable type of protective foot wear. In the case of steeply inclined tunnels and inshafts, safety belts shall also be provided.
- 9.10** Sign boards 1 x 1.5 m in size with the following wording shall be erected at the access to these areas. "CONSTRUCTION AREA, HELMET REQUIRED BEYOND THIS POINT"
- 9.11** No loose garments or ragged clothing shall be worn by the personnel engaged in tunneling operation.
- 9.12** A telephone system shall provided to ensure a positive and quick method of communication between all control location inside tunnel and portal of the tunnels when longer than 500 m and for shafts when longer than 50 m
- 9.13** Irrespective of length and bends in the tunnel, arrangements shall be made for transmitting of warning signals by any one of the following means.
- 9.13.1 By electrically operated bells, operated by battery/dry cells with the bell placed outside the tunnel and the position of the switch shifting with the progress of the tunneling work. The position of the operating switch although temporary shall be so chosen as to ensure proper accessibility and easy identification.
- 9.13.2 By the use of two field (magnet type) telephone.
- 9.13.3 Any other suitable arrangement like walkie-talkie.
- 9.14** Arrangement for rendering prompt and adequate first aid to the injured persons shall be maintained at every work site under the guidance of a medical officer-in-charge of the project. Depending upon the magnitude of the work the availability of an ambulance at a very short notice (at

	LAYING, INSTALLATION, TESTING AND COMMISSIONING OF 8” DIA. STEEL GAS PIPELINE CONNECTIVITY IN PATAN GA	
TENDER DOCUMENT NO REPL/SGL/STPL/009/22		Date: -28/11/2022

telephone call) shall be ensured.

9.15 First-aid arrangements commensurate with the degree of hazard and with the number of workers employed shall be maintained in a readily accessible place throughout the working hours. At least one experienced first-aid attendant with his distinguishing badge shall be available on each shift to take care of injured persons. Arrangements shall be made for calling the medical officer, when such a need may arise. It is recommended that foreman/assistant foreman/supervisor/ permanent workmen who are normally present at each working phase in each shift are given adequate training on first-aid methods to avoid employment of a separate attendant.

9.16 Stretchers and other equipment necessary to remove injured persons shall be provided at every shift.

9.17 Where there are more than 50 persons working in a shift, effective artificial respiration arrangements shall be provided, with trained men capable of providing artificial respiration.

10.0 ELECTRICAL



10.1 Only authorised persons shall handle or otherwise interfere with electrical equipment. Any person detecting electrical apparatus being handled by an unauthorised person or equipment in unsafe condition must report the matter to the Engineer concerned.

10.2 No person shall work on any live electric conductor or apparatus and no person shall assist such person on such work, unless he is authorised in that behalf.



10.2.1 After isolating the equipment from the source of supply before the work begins, a sign 'DONT'T SWITCH ON' must be hung on or near the switch to avoid its being accidentally or inadvertently switched on when persons are working.

10.2.2 Take out the fuses and keep in safe custody.

10.2.3 The switch may be locked if locking arrangement exists.

	LAYING, INSTALLATION, TESTING AND COMMISSIONING OF 8” DIA. STEEL GAS PIPELINE CONNECTIVITY IN PATAN GA	
TENDER DOCUMENT NO REPL/SGL/STPL/009/22		Date: -28/11/2022



- 10.2.4 Earth the equipment, before work, to discharge it and short the terminals as a precautionary measure against accidental switching ON.
- 10.2.5 After the work is finished take out Earthing and shorting link.
- 10.2.6 Remove all tools and materials from the site of work. Replace the fuses and unlock the switch.
- 10.2.7 The switch shall only be put 'ON' by the person who switched it 'OFF' or by the person authorised by him in writing.
- 10.3** When working on live equipment use one hand only whenever possible, it is advisable to keep the other hand behind the back. Shocks from hand to hand are most dangerous.
- 10.4** All persons handling electrical gear in elevated position must use safety belts. Even a slight shock may cause loss of balance and fall.
- 10.5** No one shall attempt to extinguish a fire on or near a live electrical apparatus with water. Water is a good conductor of electricity. Use extinguishers wherever provided. Use sand and blankets etc., if available.
- 10.6** No person shall use any part of electrical equipment for storing or hanging clothes, umbrellas or other articles. Serious accidents occur from this practice.
- 10.7** For attending the work on O.H. lines or equipment use wooden ladders. Metallic ladders shall not be used.
- 10.8** Use insulated tools and ensure the insulation is in proper condition periodically at least once in three months. Use rubber gloves wherever possible.
- 10.9** As far as possible verbal instructions shall be avoided in case of pre-arranged shut-down of electrical apparatus.
- 10.10** When workers are employed for electrical installations which are already energised, insulating mats, wearing apparel such as gloves, sleeves and boots as may be necessary shall be provided. The workers shall not wear any rings, watches and carry keys or other materials which are good

	LAYING, INSTALLATION, TESTING AND COMMISSIONING OF 8” DIA. STEEL GAS PIPELINE CONNECTIVITY IN PATAN GA	
TENDER DOCUMENT NO REPL/SGL/STPL/009/22		Date: -28/11/2022

conductors of electricity.

11.0 MISCELLANEOUS

- 11.1** The Contractor shall provide necessary fencing and lights to protect the public from accident.
- 11.2** Fire extinguishers adequate in number shall be kept by the Contractor at the site of works where there is risk of fire hazard.
- 11.3** Adequate washing facilities shall be provided near the place of work.
- 11.4** When the work is done near any place where there is risk of drowning, all necessary equipments shall be provided and kept ready for use and all necessary steps taken for prompt rescue of any person in danger and adequate provisions shall be made for prompt first aid treatment of all injuries likely to be sustained during the course of the work.
- 11.5** These safety provisions shall be brought to the notice of all concerned by displaying on a Notice Board at a prominent place at the work spot. The persons responsible for compliance of the code shall be named therein by the Contractor.
- 11.6** To ensure effective enforcement of the rules and regulations relating to safety precautions, the arrangements made by the Contractor shall be open to inspection by the Engineer and Owner.
- 11.7** Notwithstanding the above clauses there is nothing in those to exempt the Contractor from the operations of any other Act or Rule in force in the Republic of India.
- 11.8** All storage, handling and use of flammable liquids shall be under the supervision of qualified persons. Flammable liquid shall not be stored inside the tunnel
- 11.9** All sources of ignition shall be prohibited in areas where flammable liquids are stored, handled and processed. Suitable warning and 'NO SMOKING' signs shall be posted in all such places. Receptacles containing flammable liquids shall be stacked in such a manner as to permit free passage of air between them.

	LAYING, INSTALLATION, TESTING AND COMMISSIONING OF 8” DIA. STEEL GAS PIPELINE CONNECTIVITY IN PATAN GA	
TENDER DOCUMENT NO REPL/SGL/STPL/009/22		Date: -28/11/2022

- 11.10** All combustible materials shall be continuously removed from such areas where flammable liquids are stored, handled and processed. All spills of flammable liquids shall be cleared up immediately. Containers of flammable liquids shall be tightly capped.

12.0 REPORTING OF ACCIDENT

All accidents, major or minor must be reported immediately. The Contractor, will provide first aid to the injured person immediately and the injured person shall report to the first aid station along with the 'INJURED ON WORK' form duly filled in quintuplicate and submit to the Medical Officer of the First Aid Station".

Serious Injury

In case of serious injury, the following procedure shall be adopted by the Contractor:



1. Provide First Aid at his own First Aid Station.
2. Take the injured person to the Hospital along with the "INJURED ON WORK" form duly filled in.
3. Reporting the accident to the Owner/Engineer by the Contractor.

Fatal Accident

Fatal accident must be reported immediately to the Engineer/Owner as well as to the Police.

Penalty



Failure to observe the Safety Rules will make the Contractor liable to penalty by way of suspension of work, fine and termination of contract.

	LAYING, INSTALLATION, TESTING AND COMMISSIONING OF 8" DIA. STEEL GAS PIPELINE CONNECTIVITY IN PATAN GA	
TENDER DOCUMENT NO REPL/SGL/STPL/009/22		Date: -28/11/2022

SPECIFICATION FOR CIVIL WORKS

ANNEXURE- A

LIST OF IS & IRC CODES REFERRED

	LAYING, INSTALLATION, TESTING AND COMMISSIONING OF 8” DIA. STEEL GAS PIPELINE CONNECTIVITY IN PATAN GA	
TENDER DOCUMENT NO REPL/SGL/STPL/009/22		Date: -28/11/2022

ANNEXURE - A

LIST OF IS & IRC CODES REFERRED

IS 383	:	Specification for coarse & fine aggregates from natural sources for concrete.
IS 2386 (Part 1 to 8)	:	Method of Test for aggregates for concrete
IS 456	:	Code of practice for plain and reinforced concrete.
IS 712	:	Specification for building limes.
IS 3182	:	Specification for broken brick (burnt clay) fine aggregate for use in limemortar.
IS 269	:	Specification for 33 grade ordinary Portland Cement.
IS 455	:	Code of practice for Portland Slag Cement.
IS 1489	:	Specification for Portland Pozzolana Cement.
IS 8041	:	Specification for rapid hardening Portland Cement.
IS 8112	:	Specification for 43 grade ordinary Portland Cement.
IS 12269	:	Specification for 53 grade ordinary Portland Cement.
IS 8043	:	Specification for Hydrophobic Portland Cement
IS 12330	:	Specification for Sulphate resisting Portland Cement.
IS 6452	:	Specification for high alumina cement for structural use.



**LAYING, INSTALLATION,
TESTING AND COMMISSIONING
OF 8" DIA. STEEL GAS PIPELINE
CONNECTIVITY IN PATAN GA**



TENDER DOCUMENT NO
REPL/SGL/STPL/009/22

Date: -28/11/2022

IS 8042	:	Specification for White Portland Cement.
IS 3535	:	Methods of sampling Hydraulic Cement.
IS 4031 (Part 1 to 15)	:	Methods of test for Hydraulic Cement.
IS 4032	:	Method of Chemical Analysis of Hydraulic Cement.
IS 2645	:	Specification for Integral Cement Waterproofing Compounds.
IS 1599	:	Method of Bend Test.
IS 1608	:	Method of Tensile Testing of Steel Products.
IS 6925	:	Method of test for determination of Water Soluble Chlorides in concrete admixtures.
IS 432	:	Specification for mild steel and medium tensile steel bars and hard drawn steel wire for concrete reinforcement.
IS 1786	:	Specification for high strength deformed steel bars and wires for concrete reinforcement.
IS 1566	:	Specification for hard drawn steel wire fabric for concrete reinforcement.
IS 280	:	Mild steel wire for general engineering purposes.
IS 2062	:	Structural steel (Standard Quality).
IS 1161	:	Steel Tubes for Structural purposes.
IS 5624	:	Foundation bolts.
IS 1363 - (Part 1 to 3)	:	Hexagon Head bolts, screws, nuts.
IS 2016	:	Plain washers.
IS 3063	:	Single coil rectangular section spring washers.
IS 1239 (Part 1&2)	:	Mild Steel Tubes and other wrought steel



**LAYING, INSTALLATION,
TESTING AND COMMISSIONING
OF 8” DIA. STEEL GAS PIPELINE
CONNECTIVITY IN PATAN GA**



TENDER DOCUMENT NO
REPL/SGL/STPL/009/22

Date: -28/11/2022

		pipe fittings.
IS 1367	:	Technical supply conditions for threaded steel fasteners.
IS 1030	:	Carbon steel castings.
IS 3480	:	Flexible steel conduit for electrical wiring.
IS 2667	:	Fittings for rigid steel conduits for electricalwiring.
IS 9537 (Part 3)	:	Conduit for electrical installations - Rigid Plain conduits of insulating materiel.
IS 6946	:	Flexible non-metallic conduits for electrical installations.
IS 3419	:	Fittings for rigid non-metallic conduits.
IS 5913	:	Methods of tests for Asbestos CementProducts.
IS 2098	:	Specification for asbestos cement buildingboards.
IS 2096	:	Specification for asbestos cement flatsheets.
IS 9537 (Part 2)	:	Conduit for electrical installations - Rigid steel conduits.
IS 2614	:	Method for sampling of fasteners.
IS 1592	:	Specification for asbestos cementpressurepipes.
IS 9627	:	Specification for asbestos cementpressure pipe (Light duty).
IS 6908	:	Specification for asbestos cement pipes and fittings for sewerage anddrainage.
IS 1626 (Part 1 to 3)	:	Specification for asbestos cement building pipes and pipe fittings and roofing fittings
IS 459	:	Specification for unreinforced corrugated and semi corrugated asbestos cement sheets
IS 1077	:	Specification for common burnt clay building bricks.



**LAYING, INSTALLATION,
TESTING AND COMMISSIONING
OF 8" DIA. STEEL GAS PIPELINE
CONNECTIVITY IN PATAN GA**



TENDER DOCUMENT NO
REPL/SGL/STPL/009/22

Date: -28/11/2022

IS 3495 (Part 1 to 4)	:	Method of Test for burnt clay building bricks.
IS 3620	:	Specification for laterite stone block formasonry.
IS 1121	:	Method of test for determination of strength properties of natural building stone.
IS 1124	:	Method of test for determination of waterabsorption Sp. Gr. etc. of building stones
IS 1125	:	Method of test for determination of weathering of natural building stones.
IS 1126	:	Method of test for determination of duraof building stone.
IS 1127	:	Recommendation for dimensions and workmanship of natural building stones for masonry work.
IS 2185 (Part-1)	:	Specification for concrete masonry unitHollow and solid concrete blocks.
IS 2116	:	Specification for sand for masonry mortar
IS 1542	:	Specification for sand for plaster.
IS 2185 (Part-2)	:	Specification for concrete masonry unit-Hollow and solid light weight concrete blocks.
IS 2185 (Part-3)	:	Specification for concrete masonry unit-Auto claved Cellular Aerated concreteblocks.
IS 6041	:	Code of practice for construction of Auto claved Cellular concrete blockmasonry.
IS 6441 (Part 1 to 9)	:	Method of Test for Auto claved Concrete Products.
IS 3068	:	Specification for broken brick (burnt clay) coarse



**LAYING, INSTALLATION,
TESTING AND COMMISSIONING
OF 8" DIA. STEEL GAS PIPELINE
CONNECTIVITY IN PATAN GA**



TENDER DOCUMENT NO
REPL/SGL/STPL/009/22

Date: -28/11/2022

aggregates for use in lime concrete.

IS 2114	: Code of practice for laying in-situ terrazzo floor finish.
IS 460 (Part 1 to 3)	: Specification for Test Sieves.
IS 1237	: Specification for cement concrete flooring tiles.
IS 777	: Specification for glazed earthen ware walltiles.
IS 1129	: Recommendation for dressing of natural building stone.
IS 1130	: Specification for Marble (blocks, slabs and tiles).
IS 809	: Specification for rubber flooring materials for general purposes.
IS 3462	: Specification for unbacked flexible PVC flooring.
IS 3461	: Specification for PVC asbestos floor tiles
IS 2818	: Indian Hessians.
IS 653	: Linoleum sheets and tiles.
IS 5389	: Code of practice for laying hard wood parquet and wood block flooring.
IS 210	: Grey Iron Castings.
IS 2114	: Code of practice for laying in-situ terrazzo finish.
IS 1198	: Code of practice for laying of linoleum flooring.
IS 1003 (Part-2)	: Specification for timber panelled & glazed shutters, windows and ventilator shutters.
IS 1141	: Code of practice for seasoning of timber.
IS 1003 (Part-1)	: Specification for timber panelled & glazed shutters - Door shutters.
IS 287	: Recommendation for maximum permissible moisture content of timber used for different purposes.



**LAYING, INSTALLATION,
TESTING AND COMMISSIONING
OF 8" DIA. STEEL GAS PIPELINE
CONNECTIVITY IN PATAN GA**



TENDER DOCUMENT NO
REPL/SGL/STPL/009/22

Date: -28/11/2022

- IS 2202 (Part-1) : Specification for wooden flush door shutters (Solid core type).
- IS 2191 (Part-1&2) : Specification for wooden flush door shutters (Cellular and hollow core type).
- IS 3087 : Specification for wood particle boards (Medium density) for general purposes.
- IS 3478 : Specification for high density wood particleboards.
- IS 3097 : Specification for veneered particle boards
- IS 303 : Specification for plywood for general purposes.
- IS 1328 : Specification for veneered decorative plywood.
- IS 205 : Specification for non-ferrous metal butt A-8 hinges.
- IS 1341 : Specification for steel butt hinges.
- IS 362 : Specification for parliament hinges.
- IS 453 : Specification for double acting spring hinges.
- IS 3818 : Specification for continuous (Piano) hinges.
- IS 206 : Specification for Tee and Strap hinges.
- IS 281 : Specification for mild steel sliding door bolts for use with padlocks.
- IS 1019 : Specification for rim latches.
- IS 2681 : Specification for non-ferrous metal sliding door bolts for use with padlocks.
- IS 204 (Part 1&2) : Specification for tower bolts - Ferrous and Non-ferrous metals.
- IS 208 : Specification for door handles.
- IS 2209 : Specification for mortice locks (vertical type).
- IS 6607 : Specification for rebated mortice locks (vertical type).



**LAYING, INSTALLATION,
TESTING AND COMMISSIONING
OF 8” DIA. STEEL GAS PIPELINE
CONNECTIVITY IN PATAN GA**



TENDER DOCUMENT NO
REPL/SGL/STPL/009/22

Date: -28/11/2022

IS 1823	:	Specification for floor door stoppers.
IS 1837	:	Specification for fan light pivots.
IS 207	:	Gate and shutter hooks and eyes.
IS 6343	:	Specification of door closers (pneumatically regulated) for light door weighing upto 40 Kg.
IS 8756	:	Specification for ball catches for use in wooden Almirah.
IS 6315	:	Specification for floor springs (hydraulically regulated) for heavy doors.
IS 7197	:	Specification for Double action floor spring (without oil check) for heavy doors
IS 364	:	Specification for fan light catch.
IS 3828	:	Specification for ventilator chains.
IS 363	:	Specification for hasp and staples.
IS 9899	:	Specification for hat, coat and wardrobe hooks.
IS 729	:	Specification for drawer locks, cup-board locks and box locks.
IS 3564	:	Specification for door closers (Hydraulically regulated).
IS 4351	:	Specification for steel door frames.
IS 419	:	Putty for use on window frames.
IS 5187	:	Specification for flush bolts.
IS 3847	:	Specification for mortice night latches.
IS 4621	:	Specification for indicating bolts.
IS 1038	:	Specification for steel doors, windows and ventilators.
IS 1977	:	Structural steel (ordinary quality).
IS 1361	:	Specification for steel windows for industrial buildings.



**LAYING, INSTALLATION,
TESTING AND COMMISSIONING
OF 8" DIA. STEEL GAS PIPELINE
CONNECTIVITY IN PATAN GA**



TENDER DOCUMENT NO
REPL/SGL/STPL/009/22

Date: -28/11/2022

IS 7452	:	Hot rolled steel sections for doors, windows and ventilators.
IS 1948	:	Specification for aluminium doors, windows and ventilators.
IS 1148	:	Specification for hot rolled rivet bars for structural purposes.
IS 1949	:	Specification for aluminium windows for industrial buildings.
IS 204 (Part 1)	:	Specification for tower bolts-non-ferrous metal.
IS 733	:	Wrought aluminium and aluminium alloy bars, rods and sections (for general engineering purposes).
IS 6248	:	Specification for metal rolling shutters and rolling grills.
IS 1081	:	Code of practice for fixing and glazing of metal doors, windows and ventilators.
IS 2339	:	Specification for Aluminium Paint for general purpose in dual containers.
IS 2835	:	Flat Transparent sheet glass.
IS 5437	:	Wired and figured glass.
IS 101 (Part 1 to 8)	:	Method of sampling and test for paints, varnishes and related products.
IS 2074	:	Ready mixed paint, air drying, red oxide zink chrome, priming.
IS 5410	:	Cement paint, colour as required.
IS 427	:	Distemper, dry, colour as required.
IS 428	:	Distemper, oil emulsion, colour as required.
IS 348	:	French polish.



**LAYING, INSTALLATION,
TESTING AND COMMISSIONING
OF 8" DIA. STEEL GAS PIPELINE
CONNECTIVITY IN PATAN GA**



TENDER DOCUMENT NO
REPL/SGL/STPL/009/22

Date: -28/11/2022

IS 5411 (Part 1&2)	:	Plastic emulsion paint.
IS 702	:	Industrial Bitumen.
IS 73	:	Paving Bitumen.
IS 217	:	Cut Back Bitumen.
IS 454	:	Specification for Digboi type cutback bitumen.
IS 5467	:	Specification for shellac Wax.
IS 3384	:	Specification for Bitumen primer for use in water proofing and damp proofing.
IS 290	:	Specification for Coal Tar Black Paint.
IS 341	:	Specification for Black Japan, Type A, B & C.
IS 1322	:	Specification for bitumen felts for water proofing and damp proofing.
IS 218	:	Specification for creosote oil for use as wood preservative.
IS 3037	:	Specification for Bitumen mastic for use in water proofing of roofs.
IS 1580	:	Specification for Bituminous compound for water proofing and caulking purposes.
IS 8542	:	Specification for polish for wooden furniture paste.
IS 9862	:	Ready mixed paint, brushing etc.
IS 782	:	Specification for caulking lead.
IS 405 (Part 1&2)	:	Lead sheet and strips.
IS 5134	:	Bitumen impregnated paper.
IS 2849	:	Specification for non load bearing gypsum partition blocks.
IS 8591	:	Specification for floor polish paste.
IS 2095	:	Specification for gypsum plaster boards.
IS 77	:	Specification for linseed oil, boiled for paints.



**LAYING, INSTALLATION,
TESTING AND COMMISSIONING
OF 8” DIA. STEEL GAS PIPELINE
CONNECTIVITY IN PATAN GA**



TENDER DOCUMENT NO
REPL/SGL/STPL/009/22

Date: -28/11/2022

IS 533	:	Gum Spirit of turpentine (oil of Turpentine).
IS 1504	:	Bees Wax.
IS 3536	:	Ready mixed paint, brushing, wood primerpink.
IS 8273	:	Specification for gypsum plaster for use in the manufacture of fibrous plaster board.
IS 5871	:	Specification for bitumen mastic for tanking and damp proofing.
IS 651	:	Specification for salt glazed stoneware pipe and fittings.
IS 1729	:	Sand cast iron spigot and socket soil pipe. IS 771
(Part 1 to 7)	:	Specification for glazed fire clay appliances.
IS 1230	:	Cast iron rain water pipes and fittings.
IS 774	:	Flushing cisterns for water closets and urinals.
IS 2548 (Part 1&2)	:	Specification for plastic seats and cover for water closet.
IS 1726	:	Specification for cast iron manhole coverand frames.
IS 1239 (Part 1&2)	:	Mild steel Tubes and fittings.
IS 4984	:	Specification for high density polyethylene pipes for potable water supplies: Sewerage and industrial effluents.
IS 2556 (Part 1 to 15)	:	Specification for vitreous sanitary appliances (vitreous china).
IS 7328	:	High density polyethylene materials.
IS 4985	:	Specification for unplasticised PVC pipesfor potable water supplies.
IS 3076	:	Specification for low density polyethylene pipe for potable water supplies.



**LAYING, INSTALLATION,
TESTING AND COMMISSIONING
OF 8" DIA. STEEL GAS PIPELINE
CONNECTIVITY IN PATAN GA**



TENDER DOCUMENT NO
REPL/SGL/STPL/009/22

Date: -28/11/2022

- IS 9762 : Specification for polyethylene floats for ballvalve.
- IS 3395 : Code of practice for fire safety of industrial buildings.
- IS 7834 (Part 1 to 8) : Specification for injection moulded PVC fittings with solvent cement joint for watersupplies.
- IS 8008 (Part 1 to 7) : Specification for injection moulded HDPE fittings for potable water supplies.
- IS 8360 (Part 1 to 3) : Specification for fabricated high density polyethylene fittings for potable water.
- IS 784 : Specification for prestressed concrete pipe.
- IS 1703 : Specification for copper alloy float valves(horizontal plunger type) for water supply fittings.
- IS 12234 : Specification for plastic equilibrium float valve for cold water services.
- IS 778 : Specification for copper alloy gate, globe and check valves for water works purposes.
- IS 1536 : Centrifugally cast (spun) iron pressure pipes.
- IS 1537 : Vertically cast iron pressure pipes for water, gas and sewage.
- IS 1538 (Part 1 to 23) : Sand cast iron spigot and socket soil, waste and ventilating pipes, fittings and accessories.
- IS 3589 : Electrically welded steel pipes for water, gas and sewage.
- IS 781 : Specification for cast copper alloy screw down bib taps and stop valves for water services.
- IS 1239 (Part 1&2) : Mild steel tubes and fittings.



**LAYING, INSTALLATION,
TESTING AND COMMISSIONING
OF 8" DIA. STEEL GAS PIPELINE
CONNECTIVITY IN PATAN GA**



TENDER DOCUMENT NO
REPL/SGL/STPL/009/22

Date: -28/11/2022

IS 779	:	Specification for water meters.
IS 1795	:	Specification for pillar taps for water supply purposes.
IS 1363 (Part 1 to 3)	:	Dimensions for screw thread run-outs and undercuts.
IS 2016	:	Plain washers.
IS 638	:	Sheet rubber jointing and rubber insertion jointing.
IS 4127	:	Code of practice for laying of glazed stoneware pipes.
IS 458	:	Specification for precast concrete pipes.
IRC 19	:	Standard specification and code of practice for water Bound macadam.
IRC 29	:	Tentative specification for 4 cm Asphaltic concrete surface course.
IRC 15	:	Standard specification and code of practice for construction of concrete roads.
IS 6313	:	Code of practice for antitermite measures in building.
IS 1054	:	Dieldrin emulsifiable concentrates.
IS 1308	:	Aldrin dusting powders.
IS 6439	:	Hepta chlor emulsifiable concentrates.
IS 2632	:	Crotonaldehyde.
IS 1791	:	Specification for batch type concrete mixers.
IS 10262	:	Recommended guidelines for concrete mix design.
IS 7861 (Part 1)	:	Code of practice for extreme weather concreting - Recommended practice for hot weather concreting.



**LAYING, INSTALLATION,
TESTING AND COMMISSIONING
OF 8" DIA. STEEL GAS PIPELINE
CONNECTIVITY IN PATAN GA**



TENDER DOCUMENT NO
REPL/SGL/STPL/009/22

Date: -28/11/2022

IS 1199	: Methods of sampling and analysis for concrete.
IS 516	: Method of test for strength of concrete.
IS 7861 (Part 2)	: Code of practice for extreme weather concreting. Recommended practice for cold weather concreting.
IS 2502	: Code of practice for bending and fixing of bars for concrete reinforcement.
IS 2751	: Recommended practice for welding of mild steel plain and deformed bars for reinforced construction.
IS 800	: Code of practice for general construction in steel and deformed bars.
IS 816	: Code of practice for use of metal arc welding.
IS 814	: Covered electrodes for manual metal arc.
IS 3370 (Part 1&2)	: Code of practice for concrete structures for the storage of liquids.
IS 2911 (Part 1 to 4)	: Code of practice for design and construction of pile foundations.
IS 1343	: Code of practice for prestressed concrete.
IS 1785 (Part 1&2)	: Specification for plane hard drawn steel wires for prestressed concrete.
IS 2250	: Code of practice for preparation and use of masonry mortars.
IS 1635:	: Code of practice for field slaking of building lime.
IS 2212	: Code of practice for brick work.
IS 1597 (Part 1&2)	: Code of practice for construction of stone masonry.
IS 4101 (Part 1 to 3)	: Code of practice for external facing and veneer.
IS 737	: Wrought aluminium and aluminium alloys, sheet and



**LAYING, INSTALLATION,
TESTING AND COMMISSIONING
OF 8" DIA. STEEL GAS PIPELINE
CONNECTIVITY IN PATAN GA**



TENDER DOCUMENT NO
REPL/SGL/STPL/009/22

Date: -28/11/2022

strips (for general engineering purposes).

- IS 2572 : Code of practice for construction of hollow connect block masonry.
- IS 1661 : Code of practice for application of cement finishes.
- IS 5766 : Code of practice for laying of burnt clay brick flooring.
- IS 5491 : Code of practice for laying of in-situ granolithic concrete flooring topping.
- IS 3316 : Specification for structural granite.
- IS 1196 : Code of practice for laying bitumen mastic flooring.
- IS 1195 : Specification for bitumen mastic for flooring.
- IS 3462 : Specification for unbacked flexible PVC flooring.
- IS 1198 : Code of practice for laying fixing and maintenance of linoleum floor.
- IS 848 : Specification for synthetic resin adhesive for plywood.
- IS 4457 : Specification for ceramic unglazed vitreous acid resisting tiles.
- IS 851 : Specification for synthetic resin adhesive for construction work (non structural) for wood.
- IS 2202 (Part 1&2) : Specification for wooden flush door shutters.
- IS 102 : Ready mixed paint.
- IS 1081 : Code of practice for fixing and glazing of metal doors.
- IS 6248 : Specification for metal rolling shutters and rolling grills.
- IS 1868 : Anodic coatings on aluminium and its alloys.



**LAYING, INSTALLATION,
TESTING AND COMMISSIONING
OF 8" DIA. STEEL GAS PIPELINE
CONNECTIVITY IN PATAN GA**



TENDER DOCUMENT NO
REPL/SGL/STPL/009/22

Date: -28/11/2022

IS 2065	: Code of practice for water supply inbuildings.
IS 2064	: Code of practice for selection, installation and maintenance of sanitary appliances.
IS 7634 (Part 1 to 3)	: Code of practice for plastic pipes.
IS 1742	: Code of practice for building drainage.
IS 5330	: Criteria for design of anchor blocks for penstocks with expansion joints.
IS 3114	: Code of practice for laying of cast ironpipes.
IS 783	: Code of practice for laying of concretepipes.
IRC-SP11	: Hand book of quality control for construction of roads and run-ways.
IRC-63	: Tentative guidelines for use of low-grade aggregates and soil aggregate mixtures in road pavement construction.
IRC-60	: Tentative guidelines for use of Lime Fly Ash Concrete as pavement base or sub-base.
IRC-74	: Tentative guidelines for use of Lean Cement Concrete and lean concrete FlyAsh Concrete as pavement base or sub- base.
IS 6509	: Code of practice for installation of joints in concrete pavement.
IS 1838 (Part 1)	: Specification for performed filler for expansion joint in concrete pavements andstructures.
IRC-43	: Recommended practice for Tools, Equipment and appliances for concrete pavement construction.
IRC-15	: Standard specifications and code of practice for construction of concrete road.
IS 3036	: Code of practice for laying lime concrete for a water



**LAYING, INSTALLATION,
TESTING AND COMMISSIONING
OF 8" DIA. STEEL GAS PIPELINE
CONNECTIVITY IN PATAN GA**



TENDER DOCUMENT NO
REPL/SGL/STPL/009/22

Date: -28/11/2022

proofed roof finish.

- IS 1346 : Code of practice for water proofing of roofs with bitumen felts.
- IS 1609 : Code of practice for laying damp proofing treatment using bitumen felt.
- IS 4365 : Code of practice for application of bitumen mastic for waterproofing of roofs.
- IS 9103 : Specification for admixtures for concrete.
- IS 2645 : Specification for integral cement water proofing compounds.
- IS 1834 : Specification for hot applied sealing compound for joint in concrete.
- IS 278 : Specification for Galvanized barbed wire for fencing.
- IS 2721 : Specification for Galvanized steel chain link fabric.
- IS 280 : Specification for Mild steel wire.
- IS 4826 : Specification for hot dipped galvanized coating on round steel wires.
- IS 1200 (Part 1 to 28) : Method of measurement of building and Civil Engineering Works.
- IS 4081 : Safety code for blasting.
- IS 5916 : Specification for cast iron gratings for drainage purposes.
- IS 4130 : Safety Code for demolition of building.
- IS 3764 : Safety code for excavation work.
- IS 5121 : Safety code for piling.
- IS 4014 (Part 2) : Code of practice for steel tubular scaffolding.



**LAYING, INSTALLATION,
TESTING AND COMMISSIONING
OF 8" DIA. STEEL GAS PIPELINE
CONNECTIVITY IN PATAN GA**



TENDER DOCUMENT NO
REPL/SGL/STPL/009/22

Date: -28/11/2022

IS 3696 (Part 1&2)	:	Safety code of scaffolds and ladders.
IS 6922	:	Criteria for safety and design of structures subject to underground blast.
IS 5499	:	Code of practice for construction of underground raid shelter.
IS 4138	:	Safety code for working in compressed air.
IS 7293	:	Safety code for working with construction machinery.
IS 8989	:	Safety code for erection of concrete framed structures.
IS 4756	:	Safety code for Tunneling work.
IS 7205	:	Safety code for erection of structural steelworks.



**LAYING, INSTALLATION,
TESTING AND COMMISSIONING
OF 8" DIA. STEEL GAS PIPELINE
CONNECTIVITY IN PATAN GA**



TENDER DOCUMENT NO
REPL/SGL/STPL/009/22

Date: -28/11/2022





Sabarmati Gas Ltd.
(A Joint Venture of GSPC and BPCL)

SABARMATI GAS LIMITED

**Laying, Installation, Testing and Commissioning of 8" dia. Steel gas
pipeline connectivity in PATAN GA**



RESONANCE ENERGY PVT. LTD.

**Specification for Temporary Cathodic Protection
Tender No. REPL/SGL/STPL/009/22**

	LAYING, INSTALLATION, TESTING AND COMMISSIONING OF 8" DIA. STEEL GAS PIPELINE CONNECTIVITY IN PATAN GA	
TENDER DOCUMENT NO REPL/SGL/STPL/009/22		Date: -28/11/2022

CONTENTS

- 1.0 SCOPE
- 2.0 CODES AND STANDARDS
- 3.0 CORROSION DATA
- 4.0 CATHODIC PROTECTION DESIGN PARAMETERS
- 5.0 CATHODIC PROTECTION DESIGN CRITERIA
- 6.0 SYSTEM DETAILS
- 7.0 INSTALLATION
- 8.0 CIVIL WORKS
- 9.0 TESTING AND INSPECTION AT WORKS
- 10.0 PACKING AND TRANSPORT
- 11.0 SYSTEM TESTING COMMISSIONING AND INTERFERENCE MITIGATION
- 12.0 SYSTEM MONITORING
- 13.0 DRAWINGS AND DOCUMENTS
- 14.0 INSTRUMENTS, TOOLS AND SPARES
- 15.0 INFORMATION REQUIRED WITH BID

	LAYING, INSTALLATION, TESTING AND COMMISSIONING OF 8” DIA. STEEL GAS PIPELINE CONNECTIVITY IN PATAN GA	
TENDER DOCUMENT NO REPL/SGL/STPL/009/22		Date: -28/11/2022

1.0 SCOPE

- 1.1 This specification defines the requirements of design, engineering supply of materials, installation, testing and commissioning of temporary cathodic protection system of external surface of cross country underground pipeline/structure including supplementing of corrosion survey, investigation for interference/interaction problems and mitigation of the same. Unless otherwise specified monitoring of the temporary cathodic protection system till the commissioning of permanent C.P. System shall be carried out by temporary C.P. contractor.



This specification defines the basic guidelines to develop a suitable temporary cathodic protection system for the structure required to be protected. All data required in this regard shall be taken into consideration to develop an acceptable design and for proper engineering of the system.

- 1.2 Compliance with these specifications and/ or approval of any of the contractor's documents shall in no case relieve the contractual obligations.
- 1.3 In case where temporary and permanent cathodic protection works are being executed by the same agency, activities of permanent CP system which are common to temporary CP system shall be completed as part of temporary CP system. In cases where temporary and permanent cathodic protection works are being executed by different agencies, the contractual scope of work shall be referred for further details.
- 1.4 All work to be performed and supplies to be effected as a part of contract shall require specific approval of owner or his authorised representative. Major activities requiring approval shall include but not be limited to the following :-
- Corrosion survey data interpretation report and design basis for CP system.
 - CP system design package
 - Purchase requisitions for major equipment and vendor approval
 - Detailed engineering package
 - Field testing and commissioning procedure
 - Procedures for interference testing and mitigation
 - CPL survey and system monitoring procedures

2.0 CODES AND STANDARDS

The system design, performance and materials to be supplied shall unless otherwise specified, conform to the requirements of latest relevant applicable standards of :-

BIS specifications
BS specifications and codes of practice
ANSI specifications
NFPA publications
NACE publications
IEC publications
DNV publications
IEEE publications
DIN publications
ASTM publications

	LAYING, INSTALLATION, TESTING AND COMMISSIONING OF 8" DIA. STEEL GAS PIPELINE CONNECTIVITY IN PATAN GA	
TENDER DOCUMENT NO REPL/SGL/STPL/009/22		Date: -28/11/2022

In case of conflicting requirements amongst any of the above standards the publication having most stringent requirement shall be governing.

3.0 CORROSION DATA

3.1 The corrosion survey including soil resistivity data along ROW and other data required for CP design is attached with this document. However, verification of its veracity and adequacy shall be the entire responsibility of the contractor. In addition, contractor shall have to generate/ collect additional data as required for completeness of the job. Contractor shall also carry out soil resistivity survey at temporary mode ground bed locations for proper design of ground beds. Wenner's 4-pin method or approved equal shall be used for such measurements. Survey instruments shall have maximum AC and DC ground current rejection feature.

3.2 Additional data to be collected

The following data shall be collected to generate design data for evaluation of interaction/ interference possibilities due to presence of other services in ROW/ in vicinity.

- i. Route and types of foreign service/pipeline in and around or crossing the right of way (including those existing and those which are likely to come up during contract execution or any abandoned pipelines.
- i. Diameter, wall thickness, pressure, pipeline coating against corrosion, soil cover used in case of pipelines.
- ii. Detail of the existing cathodic protection system protecting the services i.e. location, rating, type of protection, anode beds, test station locations and their connection schemes.
- iii. Graphical representation of existing structure/ pipe-to soil potential records. T/R unit current/ voltage readings.
- iv. Remedial measures existing on foreign pipeline/services to prevent interaction.
- v. Possibility of intergration/isolation of CP system, Which may involve negotiations with owners of other services.
- vi. Crossing and parallel running of electrified and non-electrified traction (along with information regarding operating voltage, type AC/DC etc.) as well as abandoned tracks near ROW having electrical continuity with the tracks in use.
- vii. Crossing and parallel running of any HT/AC/DC overhead line (existing/proposed) along with details of voltage, type AC/DC etc.
- viii. Voltage rating, number of cores and sheathing details of under ground power cables, along ROW or in its vicinity.
- ix. Information on existing and proposed DC/AC power sources and system having earth as return path, in the vicinity of the entire pipeline, route such as HV/DC sub stations, fabrication yards with electric welding etc.
- x. Any other relevant information that may be needed in designing and implementing proper protection scheme for the proposed pipeline. Unless otherwise mentioned, Contractor shall conduct necessary potential gradient



**LAYING, INSTALLATION,
TESTING AND COMMISSIONING
OF 8" DIA. STEEL GAS PIPELINE
CONNECTIVITY IN PATAN GA**



TENDER DOCUMENT NO
REPL/SGL/STPL/009/22

Date: -28/11/2022

survey for any existing anode ground bed that may interfere with the CP system of the pipeline covered under this project.

- xi. Any masonry work for other concrete or non conductive constructions in the ROW which may block the CP current or cause interference to the pipeline.
- xii. Any underground cable running in parallel or crossing the ROW.

3.3 Report

On completion of all field work a report incorporating all the results generated from surveys and details of additional data collected shall be furnished. The report shall also contain detailed interpretation of survey results and resistivity data enclosed, probable interference prone areas etc. to form design basis for the scheme of cathodic protection. This report shall be plotted on semi-log graph sheets.

4.0 CATHODIC PROTECTION DESIGN PARAMETERS

Unless otherwise specified in the project specifications, following parameters shall be used for design of temporary cathodic protection system. Those parts of sacrificial anode cathodic protection system which will be integrated with permanent CP system shall be designed based on permanent CP parameters.

4.1 Protection current density

(i) Pipe lines having polyethylene coatings

Pipeline surrounding	Protection current density*	
	Temporary CP ($\mu\text{A}/\text{m}^2$)	Permanent CP (MA/m^2)
Normal soil	50	0.120
Marshy area/ buried in sea water/ HDD crossing	100	0.120
High resistivity area (more than 100 Ω m)	25	100

(ii) Pipe lines having FBE Coatings

Pipeline surrounding	Protection current density*	
	Temporary CP ($\mu\text{A}/\text{m}^2$)	Permanent CP (MA/m^2)
Normal soil	200	0.300
Marshy area/ buried in sea water/ HDD crossing	300	0.500



**LAYING, INSTALLATION,
TESTING AND COMMISSIONING
OF 8" DIA. STEEL GAS PIPELINE
CONNECTIVITY IN PATAN GA**



TENDER DOCUMENT NO
REPL/SGL/STPL/009/22

Date: -28/11/2022

High resistivity area (more than 100Ω m)	150	0.250
--	-----	-------

Pipe to soil "ON" potential shall not be more negative than (-) 1.5V.

* Actual current density to be adopted shall be decided based upon soil and other environmental conditions, proximity of foreign pipelines and structures affecting interference. Where considered necessary for satisfactory protection of pipeline the current density shall be suitably increased by contractor.

4.2 Safety factor for current density : 1.3

4.3 Anode utilization factor : 0.65 for Mg. Anode
0.80 for Zn Anode

4.4 Pipeline natural potential : (-) 0.45 V

4.5 Unless otherwise specified in project specification the design life of temporary CP shall be one year and that of permanent CP shall be 30 years.

5.0 CATHODIC PROTECTION DESIGN CRITERIA

5.1 Cathodic protection system shall be designed to meet the following criteria:



- a. The pipe-to-electrolyte potential measurement shall be – 950 MV or more negative as measured between pipe surface and saturated Cu-CuSO₄, reference electrode containing electrolyte when cathodic protection is applied but on potential measurement shall not go more negative than (-) 1500 MV.
- b. The pipeline shall be considered protected when a minimum of (-) 300 millivolt potential shift has been achieved from the initial native potential to the CP 'ON' potential.
- c. In rare circumstances a minimum polarisation shift of (-) 100 millivolts shall indicate adequate levels of cathodic protection for the pipeline. The formation of decay of this polarisation shall be used in the criteria. Discretion to use any of the criteria listed above shall solely rest with the Owner/ Owner's representative.

5.2 A positive potential swing of 50-100 mV shall be considered the criteria for presence of an interference situation requiring investigation and incorporation of mitigation measures by the CONTRACTOR.

6.0 SYSTEM DETAILS

The system shall include the following major equipment/sub-systems unless otherwise specified:

- Sacrificial anodes and anode ground beds
- Test stations

	<p>LAYING, INSTALLATION, TESTING AND COMMISSIONING OF 8” DIA. STEEL GAS PIPELINE CONNECTIVITY IN PATAN GA</p>	
<p>TENDER DOCUMENT NO REPL/SGL/STPL/009/22</p>		<p>Date: -28/11/2022</p>

- Surge diverter/grounding cell
- Polarisation cells
- Interconnecting cables
- Cable to pipe connections
- Spark Gap Arrester

All equipment shall be new and supplied by approved reputed manufacturers. Equipment offered shall be field proven. Equipment requiring specialised maintenance or operation shall be avoided as far as possible and prototype equipment shall not be accepted. Make and construction of all material shall be subject to owner's approval. The detailed specification of each system and equipment shall be furnished by the contractor. However, certain minimum requirements for the major equipment are highlighted in this document.

As far as possible equipment including test stations, anode lead junction boxes, etc., shall be located in safe area. All equipment located in hazardous areas shall be of flame proof type as per IS:2148 for gas groups IIA & IIB and temp. class T3.

6.1 Anode Ground Beds

6.1.1 The pipeline shall be protected by prepacked zinc/ magnesium anodes.

6.1.2 Anodes shall be installed along the pipeline at suitable intervals as per pipeline protection voltage attenuation calculations and ground bed resistance/ current output of anode installations. Minimum one anode installation shall be provided for every one km. of the pipeline. In congested area, minimum one anode installation shall be provided for every 250 meter of pipeline length.

6.1.3 Each electrically continuous section of pipeline shall preferably be protected totally by one type (material) of anodes to avoid inter-anode circulation currents.



6.1.4 The anodes shall be installed at sufficient depth to reach moist soil and shall be separated from the pipe line by at least 5m and 2m for magnesium and zinc anodes respectively. The anode connections to pipeline shall be routed through test stations.

6.1.5 At the temporary cathodic protection anode ground bed, the leads of all the anodes shall be joined together in a junction box filled with epoxy and buried. A single cable shall be routed from the junction box to the test station. At permanent CP anode ground bed (i.e. at cased crossing), the leads of all the anodes shall be brought up to the test station and shall be terminated individually.

6.1.6 For sacrificial anode ground bed which shall be integrated with permanent CP System the leads of all the anodes shall be brought up to the test station and shall be terminated individually.

6.1.7 The number of anodes at each ground bed shall be sufficient for providing the specified pipe protection current density taking into consideration the ground bed resistance, pipe coating resistance, cable resistance, etc. Contractor shall prepare a table for number of anodes required at different soil resistivities to produce the specified protection current.

6.2.1 Magnesium anode

	LAYING, INSTALLATION, TESTING AND COMMISSIONING OF 8" DIA. STEEL GAS PIPELINE CONNECTIVITY IN PATAN GA	
TENDER DOCUMENT NO REPL/SGL/STPL/009/22		Date: -28/11/2022

Bentonite	20%
Sodium Sulphate	5%

6.2.5 The anodes shall be provided with cable tail of sufficient length to reach junction box test station as applicable without tension.

6.2.6 Tolerance in fabrication of anodes

The anode surface shall be free from cracks which may reduce the performance of the anode.

Any cracks which follow the longitudinal direction of elongated anodes shall not be acceptable.

Small cracks in the transverse direction of elongated anodes and in anodes of other shapes may be accepted provided the cracks would not cause any Mechanical failure during service of the anode considering that the combination of cracks and lack of bond to the anode core is detrimental.

For transverse cracks the acceptable limits shall be furnished by the bidders along with the offer.

The anode shall be free from excessive shrinkages. The following limits shall be used:

- Maximum 10% of the depth of anode or 50% of the depth of the anode core whichever is less. The depression may be measured from the edged of one side.

The surface of the anodes shall be free from coatings and slag/dross inclusions etc.

The maximum deviation from straightness shall not exceed 2%.

The weight tolerance on individual anodes may be taken as $\pm 5\%$. The total weight of the anodes shall not have negative tolerance.



Recommended dimensional tolerance shall be as follows:

Length	$\pm 2.5\%$
Width/thickness	$\pm 5\%$

6.3 Test Stations

6.3.1 Test stations shall be provided along the pipeline ROW for monitoring the performance of the Cathodic Protection system at intervals not exceeding 1000 meters in uncongested & 250 meters in congested area unless otherwise specified. In addition to above, test stations shall also be provided at the following locations:

- a. At both sides of major road crossings
- b. At all insulating joints
- c. At vulnerable locations with drastic changes in soil resistivity



	LAYING, INSTALLATION, TESTING AND COMMISSIONING OF 8" DIA. STEEL GAS PIPELINE CONNECTIVITY IN PATAN GA	
TENDER DOCUMENT NO REPL/SGL/STPL/009/22		Date: -28/11/2022

- d. At connections of surge diverters, grounding cells and polarisation cells
- e. At HT AC/DC overhead line crossings and selected locations where HT overhead line is in the vicinity of the pipeline.
- f. At both sides of railway line crossings and running parallel to the pipeline.
- g. At both sides of major river crossings.
- h. At high voltage cable crossings or along routes where HV cables are running in parallel.
- i. In the vicinity of DC networks or grounding system where interference problems are suspected.
- j. At crossings/parallel running of other pipeline structures
- k. At both sides of cased crossings
- l. At any other locations considered vulnerable locations where interference is expected
- m. At any other locations considered necessary by owner/owner's representative

- 6.3.2 Bond stations shall be provided at required locations as a means to monitor and control current flow between the pipeline and foreign pipelines / structures / electrified railway tracks etc. that crossing and running parallel to the pipeline in common ROW or within 25 metre from the pipeline.
- 6.3.3 Test stations used for sacrificial anodes shall have shunt for measurement of anode current, and provision for resistance insertion to limit the anode current output.
- 6.3.4 Test station with current measuring facility shall be provided at each intermediate CP station drainage point (to measure pipeline from drainage point), at interference prone areas, on both sides of major river crossings and at least at two additional locations along the pipeline ROW between two CP stations.
- 6.3.5 All test stations shall have weather proof enclosure, having degree of protection IP 55 with hinged lockable shutter. Enclosure shall be made of sheet steel of at least 3 mm thickness and shall be suitable for M.S. post mounting. The test stations shall be designed with terminals required for both temporary and permanent CP system and shall be suitable for total life of permanent CP system.
- 6.3.6 The test stations shall be installed with the front of the test station facing the pipeline.

The name plate of test stations shall in minimum carry following information.

- Test station number
- Chainage in km
- Test station connection scheme type
- Distance from pipeline in meters
- Direction of product flow

	LAYING, INSTALLATION, TESTING AND COMMISSIONING OF 8" DIA. STEEL GAS PIPELINE CONNECTIVITY IN PATAN GA	
TENDER DOCUMENT NO REPL/SGL/STPL/009/22		Date: -28/11/2022



- 6.3.7 Terminal blocks and different scheme of wiring as required shall be provided in the test station as per the test station connection scheme sketch.
- 6.3.8 The location of all the test stations shall be marked with their connection schemes and other relevant information's on alignment sheets. A detailed test station schedule shall be prepared.
- 6.4 Surge diverter, grounding cell and polarisation cell
- 6.4.1 Where high voltage (66 KV and above) transmission line runs in parallel or crosses the pipeline, the pipeline shall be grounded through polarisation cells & zinc anodes of minimum 20 kg net each. Alternatively, grounding could be done directly with zinc galvanic anodes of minimum 20 kg net each at the discretion of owner. Grounding shall be done at regular intervals where transmission lines run parallel within 25 meter of the pipeline to ground any surges on the pipeline that would appear in case of transmission line faults.
- 6.4.2 In case of continuous induction of voltage on the pipeline beyond safe limits is expected or observed during commissioning due to HV Line or other of any rating., the pipeline shall be grounded to the earth system of nearest HV transmission tower of the transmissison line causing the voltage induction through polarisation cell or the pipeline shall be grounded to a separate earthing system of zinc galvanic anodes through polarisation cell. Alternatively, the pipeline shall be directly grounded with zinc galvanic anodes of minimum 20 kg net each at the discretion of the owner. The polarisation cell shall be installed in test station.
- 6.4.3 Spark gap arrester shall be connected across each insulating joint to protect in from high voltage surges.
- 6.4.4 Alternatively, zinc grounding cell may be provided across insulating joints along ROW where the pipeline on both the sides of the insulating joint are cathodically protected and difference of protection voltage is not more then 0.4 volts.
Alternatively, owner on its own discretion may permit use of Magnesium / Zinc galvanic anodes for protection of insulating joints. Choice between Magnesium or zinc anodes shall depend upon the potential valves on either side of the insulating joint. These anodes shall be sized for the specified design life of permanent cathodic protection system.
- 6.4.5 The total system including cables, cable termination, anodes/ surge divertors shall be suitable for the anticipated fault current at the location of installation.
- 6.4.6 Unless otherwise specified on data sheet, the minimum rating of grounding cells, polarisation cells and surge diverters shall be as below:

(i) Grounding Cell

- Type : Zinc, 2 or 4 plate type
- Current rating : Suitable to pass more than 10kA surge

(ii) Polarisation cell

- Type : Solid state or Electrolytic multiple pairs
S.S plats type ground
- Rating : Suitable to pass 5KA or more surge

	LAYING, INSTALLATION, TESTING AND COMMISSIONING OF 8" DIA. STEEL GAS PIPELINE CONNECTIVITY IN PATAN GA	
TENDER DOCUMENT NO REPL/SGL/STPL/009/22		Date: -28/11/2022

(iii) Spark Gap Arrester

- Type : Spark gap
- Current, 8/20 wave : 100 kA
- Spark over AC voltage:
- 50 Hz : 1 kV
- Impulse (1.2/50) : 2.2 kV
micro sec)

6.4.7 The grounding cell, spark gap arresters, and polarisation cell system shall be sized for the design life of permanent CP system. The zinc or magnesium anodes meant for pipeline grounding shall also be sized for the life of the permanent CP system taking into account the current discharge from the anodes. The grounding system shall have minimum resistance to earth to restrict the pipeline voltage as per NACE criteria.

6.4.8 In case of HT transmission overhead lines of voltage below 66KV also requisite mitigation measures should be provided to take care of continuous induction of voltage interface due to presence of transmission line in close proximity.

6.5 CP at Cased Crossing

At cased crossings where casing is coated, the casing shall be protected by sacrificial anode installations. The sacrificial anode installations shall be provided at both ends of casing. The anode installation shall be sized based on permanent C.P. design parameters specified for the main pipeline.



The carrier pipe inside the casing shall be protected by zinc ribbon anodes well connected to the outer surface of bottom of carrier pipe extending upto hour hand positions of 4 and 8 o'clock. The anodes shall be placed at close intervals as per design parameters calculations and sized based on the permanent CP design parameters.

6.6 Painting

The sheet steel used for fabrication shall be thoroughly cleaned and degreased to remove mill scale, rust, grease and dirt. Fabricated structures shall be pickled and then rinsed to remove any trace of acid. The under surfaces shall be prepared by applying a coat of phosphate paint and a coat of yellow zinc chromate primer. The under surfaces shall be free from all imperfections before undertaking the finished coat. After preparation of the under surface, spray painting with two coats of final paint shall be done. The finished panel shall be dried in oven in dust free atmosphere. Panel finish shall be free from imperfections like pin holes, orange peels, run off paint, etc. All unpainted steel parts shall be cadmium plated to prevent rust information.

6.7.2 Cables

Cables shall be annealed high conductivity, tinned, stranded copper conductor, XLPE insulated 650/1100 V grade, armoured, PVC sheathed. The size of the copper conductor shall be 6 sq mm for anode cable from anode to buried junction box, 10 sq mm from junction box to test station, 10mm² from test station to pipeline. The size of the conductor shall be 6 sq mm for potential measurement, 10 sq.mm for current

	LAYING, INSTALLATION, TESTING AND COMMISSIONING OF 8" DIA. STEEL GAS PIPELINE CONNECTIVITY IN PATAN GA	
TENDER DOCUMENT NO REPL/SGL/STPL/009/22		Date: -28/11/2022

measurement and 25mm² for bonding, polarisation cell/grounding cell and surge diverter connection purpose. The anode cable from anode to junction box (buried) shall be unarmoured. The length of anode tail cable shall be sufficient enough to reach junction box (buried) in case of temporary CP anodes and up to test station in case of permanent CP sacrificial anodes. PE Sleeves shall be provided for unarmoured cables.

7.0 INSTALLATION

7.1 Cable Laying

- 7.1.1 Cables shall be laid in accordance with approved layout drawings to be prepared by the contractor. No straight through joint shall be permitted in a single run of cable. Cable route shall be carefully measured and cables cut to required length.
- 7.1.2 All cables inside station/plant area shall be laid at a depth of 0.75 M. Cables outside station/plant area shall be laid at a depth of 1.5m. Cables shall be laid in sand under brick cover back filled with normal soil. Outside the station/plant area the routes shall be marked with Polyethylene cable warning mats placed at a depth of 0.9m from the finished grade.
- 7.1.3 All underground unarmoured cables forming part of permanent CP system shall run through PE sleeves. Cables along the pipeline shall be carried along the top of the pipe by securely strapping it with adhesive tape or equivalent as required.
- 7.1.4 RCC or GI pipes of proper size shall be provided for all underground cables for road crossings.
- 7.1.5 Cables shall be neatly arranged in trenches in such a manner that criss-crossing is avoided and final take off to equipment is facilitated.

7.2 Cable to Pipe Connections

All the cable connections to the pipeline including charged foreign pipeline shall be made using an approved exothermic process. A suitable water proof sealing system of the cable connections shall be made which will be compatible with parent coating system of the pipeline after exothermic process.



For charged pipeline pin-brazing shall be used. Eutectic solder shall not be acceptable for charged or non-charged pipeline.

8.0 CIVIL WORKS

All civil works associated with the complete cathodic protection work shall be included in the scope of contractor. This shall include providing cable trenches, foundation for equipment and all test stations, etc.

9.0 TESTING AND INSPECTION AT WORKS

- 9.1 OWNER/OWNER's representative shall visit the works during manufacture of various equipment to assess the progress of work as well as to ascertain that only quality raw material is used for the same. All necessary assistance during such inspections shall be provided.

	LAYING, INSTALLATION, TESTING AND COMMISSIONING OF 8" DIA. STEEL GAS PIPELINE CONNECTIVITY IN PATAN GA	
TENDER DOCUMENT NO REPL/SGL/STPL/009/22		Date: -28/11/2022

- 9.2 The minimum testing, inspection requirements for all components/ equipments shall confirm to the requirements as defined in the relevant codes and standards. Detailed inspection and testing procedures along with the acceptance criteria shall be prepared by CONTRACTOR for OWNER's approval.
- 9.3 Test certificates including test records, performance curves etc., shall be furnished. All test certificates shall be endorsed with sufficient information to identify equipment to which the certificate refers to and must carry project title, owner's name and purchase order details etc.
- 9.4 Owner reserves the right to ask for inspection of all or any item under the contract and witness all tests and carry out inspection or authorise his representative to witness test and carry out inspection. CONTRACTOR shall notify the OWNER or OWNER's representative at least 20 days in advance giving exact details of tests, dates and addresses of locations where the tests would be carried out.

10.01 PACKING AND TRANSPORT

All equipment/material shall be protected for inland/marine transport, carriage at site and outdoor storage during transit and at site. All packages shall be clearly, legibly and durably marked with uniform block letters giving the relevant equipment/material details. Each package shall contain a packing list in a water proof envelope. Copies of the packing list in triplicate, shall be forwarded to owner prior to despatch. All items of material shall be clearly marked for easy identification against the packing list.

11.0 SYSTEM TESTING, COMMISSIONING AND INTERFERENCE MITIGATION

11.1 System testing at site

- 11.1.1 Contractor shall furnish the detailed field testing and commissioning procedure for approval. Field tests as per the approved procedures shall be carried out on the equipment/systems before being put into service. the acceptance of the complete installation shall be contingent upon inspection and field test results.
- 11.1.2 Before the CP facilities are placed in operation all necessary tests shall be carried out to establish that all equipment, devices, wiring and connection, etc., have been correctly installed, connected and are in good working condition as required for intended operation.
- 11.1.3 Owner/owner's representative may witness all the tests. At least one week's notice shall be given before commencing the tests.
- 11.1.4 All tools, equipments and instruments required for testing shall be provided by CONTRACTOR.
- 11.1.5 Generally following tests shall be carried out and recorded in proforma given in subsequent clauses:
- | | | |
|------------|---|---|
| Checking | : | Visual inspection, comparison with drawings and specifications. |
| Inspection | : | Detailed physical inspection |
| Testing | : | Simulation tests of equipment to determine its operational fitness. |

(i) Cables



**LAYING, INSTALLATION,
TESTING AND COMMISSIONING
OF 8" DIA. STEEL GAS PIPELINE
CONNECTIVITY IN PATAN GA**



TENDER DOCUMENT NO
REPL/SGL/STPL/009/22

Date: -28/11/2022

- Cable no.
- Voltage grade
- Conductor cross-section
- Continuity check
- Voltage test
- Insulation resistance values between core and earth
- All cables shall be tested by 500 V megger

(ii) Insulating joint

Checking of insulating joint for leakage, before and after energisation of C.P. by means of insulating joint tester. Structure to electrolyte potential of both protected and non-protected sides of insulating joint shall be checked before and after energisation of CP system.

(iii) Polarisation cell

- Location/identification number
- Rating
- Check for electrolyte
- Check for wiring
- Check for standby current drain with CP energisation (current drain with respect to voltage across the cell shall be recorded)

(iv) Grounding cell

- Location
- Type (no. of anodes)
- Ratings

(v) Surge diverter

- Location/identification no.
- Ratings
- Check for healthiness



(vi) Anode ground beds

- Location/test station number
- Current output of the ground bed

(vii) Spark Gap Arrester

- Location/ identification No
- Ratings
- Check for healthiness

11.2 Commissioning

	LAYING, INSTALLATION, TESTING AND COMMISSIONING OF 8” DIA. STEEL GAS PIPELINE CONNECTIVITY IN PATAN GA	
TENDER DOCUMENT NO REPL/SGL/STPL/009/22		Date: -28/11/2022

11.2.1 Natural pipe to soil potential shall be measured at each test station location prior to connecting anodes to pipeline. The pipe to soil potential observation shall be repeated after connecting the anodes and allowing sufficient time for polarisation. The current output of the anode installation shall also be measured to ensure that it does not exceed the output current capacity of the anodes. In case the anode output current exceeds the rated capacity it shall be controlled by insertion of resistance element in the anode circuit inside test station and the pipe to soil potential shall be rechecked for adequacy of protection. Additional anodes shall be provided where required to achieve desired level of protection.

Each anode installation shall become individually operational as above.

11.2.2 After connecting all the anode ground beds to pipeline, measurement of pipe to soil potentials shall be taken at each test station to ensure conformity to protection criteria.

1.2.3 In case of insufficient protection as per the CP design criteria on any portion of the pipeline, CONTRACTOR shall carry out necessary additions modification to the provided protection in consultation with the ENGINEER.

11.3 Interference Mitigation

Investigation shall be made for stray current electrolysis of the pipeline, AC induction on pipeline due to overhead high voltage line, interference due to high voltage DC lines, electric traction, etc.

Measurements including pipe to soil potential and pipeline current etc., on the pipeline/structure being CP protected shall be made to investigate the current discharge and collection locations.

In case of fluctuating stray currents investigation shall be made continuously over a period of time and if required simultaneously at different locations to find out the stray current source. For long time measurements, recorders shall preferably be used.



Where foreign pipeline (unprotected or protected by independent CP system) runs in parallel to the pipeline in same trench or very near to the pipeline, and is not bonded to the pipeline then investigation shall be made for current discharge points on both the pipelines.

Mitigation measured shall be provided depending on type of interference. These shall include installation of bond with variable resistor and diodes, installation of galvanic anodes for auxiliary drainage of current, adjustment/relocation (if possible) of offending interference source, provision of electric shield etc., depending on the type of interference.

Bonding with foreign pipeline/structure as a mitigation measure shall be provided where the owner of the pipeline/structure has no objection, otherwise, alternative mitigation measure shall be provided. Where bonding is provided for mitigation the bonding resistor shall be adjusted for optimum value for minimum/no interference. Galvanic anodes installed as a mitigation measure shall be sized for the life specified for permanent CP.

12.0 SYSTEM MONITORING

The temporary CP system provided shall be monitored at all the test stations once in a month for healthiness/adequacy of protection till commissioning of permanent CP or for design life of temporary CP specified, whichever is less. During this period if any deficiency/interference in protection system is noticed

	LAYING, INSTALLATION, TESTING AND COMMISSIONING OF 8” DIA. STEEL GAS PIPELINE CONNECTIVITY IN PATAN GA	
TENDER DOCUMENT NO REPL/SGL/STPL/009/22		Date: -28/11/2022

the same shall be rectified/augmented by additional anodes as required. The monitoring report shall be submitted regularly to owner for his review/information.

13.0 DRAWINGS AND DOCUMENTS

13.1 General

13.1.1 Within three weeks from the date of issue of PURCHASE ORDER, CONTRACTOR shall submit four copies of the list of all drawings/ data/ manuals/ procedures for approval, identifying each by a number and descriptive title and giving the schedule date. This list shall be revised and extended, as necessary, during the progress of work

13.1.2 All drawings and documents shall be in English and shall follow metric system. Number of copies of each submission shall be as follows unless otherwise specified.

Submission	No. of Copies
a. For review/approval	6
b. Drawings issued for execution construction	6
c. Final / As built drawings execution/construction	6
d. Operation/Maintenance manual, vendor data	6



13.2 Contract drawings and documents

13.2.1 As a part of the contract, drawings and documents shall be furnished which shall include but not be limited to the following:

- a. Report on corrosion survey
- b. Basis of system design calculations, equipment selection criteria and sizing calculations.
- c. Bill of material, material requisitions, purchase requisitions

13.2.2 Detailed construction drawings (including as built drawings)

- a. Sacrificial anode fabrication drawings
- b. Typical layout drawing for anode ground bed installation and connection
- c. Equipment layout, cable layout and schedules
- d. Fabrication, installation and connection scheme drawing for different types of test stations.
- e. Fabrication and installation details of surge diverter, grounding cell and polarisation cell with its enclosure and housing
- f. Cable-to-pipe joint details for charged and non-charged pipelines.

	LAYING, INSTALLATION, TESTING AND COMMISSIONING OF 8" DIA. STEEL GAS PIPELINE CONNECTIVITY IN PATAN GA	
TENDER DOCUMENT NO REPL/SGL/STPL/009/22		Date: -28/11/2022

- g. Incorporation of anode beds, polarisation cell, surge diverters, test stations, etc., and other relevant features of CP system design in Pipeline alignment sheet and other related drawings
- h. Identification of section of pipeline affected by interference, source of interference and details of interference mitigation arrangements provided. various measurement data at all relevant test stations with and without mitigation measures provided.
- i. Detailed commissioning report including various measurement data at all test stations, etc.
- j. Vendor drawings and catalogues, test certificates
- k. Operation and maintenance manual
- l. Miscellaneous
 - Equipment inspection and testing procedure
 - Construction, installation procedures
 - Field testing and commissioning procedures
 - Procedure for monitoring of cathodic protection after commissioning
 - Quality control procedures

14.0 INSTRUMENT, TOOLS AND SPARES

- 14.1 CONTRACTOR shall supply all instruments, tools and tackles necessary for proper operation and maintenance of complete cathodic protection system and associated equipment.
- 14.2 CONTRACTOR shall provide a list of spares and consumables required for proper operation and maintenance of part of cathodic protection system to be integrated with permanent CP system designed on the basis of permanent CP design parameters and associated equipment, for two years operation of the system.

15.0 INFORMATION REQUIRED WITH THE BID

Bidders are advised in their own interest to provide the following information along with the bid without which the bids are liable for summary rejection.

- a. Basis and calculations for preliminary system design for cathodic protection system.
- b. List of formulas to be used for detailed system design calculations.
- c. Basis of system design, design calculations, equipment selection criteria, sizing calculations along with characteristics curves for various equipments.
- d. Preliminary bill of material for major equipment.
- e. Details of the equipment/material offered along with technical leaflets/related literatures/catalogues, make, rating, type test certificates.
- f. Dimensions, weight and general arrangement drawings for each offered equipment.



**LAYING, INSTALLATION,
TESTING AND COMMISSIONING
OF 8" DIA. STEEL GAS PIPELINE
CONNECTIVITY IN PATAN GA**



**TENDER DOCUMENT NO
REPL/SGL/STPL/009/22**

Date: -28/11/2022

- g. List of instruments, tools and tackles offered for maintenance and operation.
- h. List of recommended maintenance/operation spares.
- l Clause-wise deviations, if any, to the specifications along with justifications